

Tender No. NHIT/FY25-26/RFP/Incident Management-02

“Request for Proposal (“RFP”) issued by National Highways Infra Trust (NHIT) for Engagement of Agency/Firm for Providing Incident Management Vehicles at Project sites under SPVs of NHIT”.

BID SUMMARY		
(i)	Last date and time for receipt of Bidding Documents	25 March 2026 up to 14:00 Hour
(ii)	Date and Time of Opening of Bids	25 March 2026 up to 16:00 Hour
(iii)	Place of Opening of Bids	Unit No.: 324, 3 rd Floor, D21 – Corporate Park, Sector-21, Dwarka, New Delhi-110077.

Note: – Bids will be opened in the presence of bidders who choose to attend as above.

NHIT Eastern Projects Private Limited

Unit No.: 325, 3rd Floor, D21 – Corporate Park,
Sector-21, Dwarka –110077, Delhi

Email: tender@nhit.co.in

Date: 16.03.2026

National Highways Infra Trust



RFP for Providing Incident Management Vehicles

Doc No.: NHIT/FY25-26/RFP/
Incident Management-02

Contents

Disclaimer	4
1. Invitation for Bids (IFB).....	5
1.1. Brief Overview of the Work under Consideration.....	5
1.2. Key Dates.....	5
1.3. Eligibility Criteria (Summary)	5
1.4. Contact Information	5
2. Instructions to Bidders (ITB)	6
2.1. Definitions and Interpretations	6
2.2. Instructions to Bidders - General Instructions	12
2.3. Bid Process Overview.....	25
2.4. Bid Security Details.....	28
2.5. Clarifications and Addendum.....	29
2.6. Bid Validity Period	30
2.7. Evaluation Process	31
3. Eligibility and Qualification Criteria	32
3.1. General Eligibility Criteria.....	32
3.2. Technical Criteria (Similar Project Experience).....	33
3.3. Specific Eligibility Criteria.....	33
3.4. Technical Evaluation Criteria	34
3.5. Documents to be Furnished.....	35
3.6. Financial Criteria (Net Worth, Turnover, etc.)	36
3.7. Legal and Regulatory Requirements.....	37
3.8. Disqualification Criteria	38
4. Project Information	42
4.1. Scope of Work.....	42
4.2. Site Details and Location Maps.....	42
4.3. Environmental and Statutory Clearances.....	43
5. Terms and Conditions of Contract	45
5.1. General Conditions of Contract (GCC).....	45
5.2. Special Conditions of Contract (SCC)	45
5.3. Contract Data (Project-Specific Details)	45
6. Design and Construction Requirements	47
6.1. Design Requirements	47
6.2. Construction Requirements.....	47
6.3. Technical Specifications	47

National Highways Infra Trust

 National Highways Infra Trust	RFP for Providing Incident Management Vehicles	Doc No.: NHIT/FY25-26/RFP/ Incident Management-02
--	---	---

6.4.	Approved Drawings (Plans, Layouts, Sections, etc.)	47
6.5.	Utility Shifting Guidelines (if applicable)	47
7.	Quality Assurance and Control Requirements	49
7.1.	Standards to be Adhered to (MoRTH, IRC, IS, etc.)	49
7.2.	Contractor's QA/QC Obligations	49
8.	Health, Safety, and Environmental (HSE) Guidelines.....	51
8.1.	HSE Requirements.....	51
8.2.	Environmental Management Plan (EMP)	52
9.	Financial Proposal.....	55
9.1.	Format for Financial Bid Submission.....	55
9.2.	Payment Schedule	55
9.3.	Bill of Quantities.....	56
9.4.	Right to Renegotiate or Re-Tender.....	56
9.5.	Taxation Details	57
10.	Performance and Security Documents	57
10.1.	Performance Security Template (Annexure [B2])	57
10.2.	Bank Guarantee Template (for Advance Payment) (Annexure [B3]).....	57
11.	Supplementary Information for Bidders	58
11.1.	Draft Contract Agreement.....	58
11.2.	List of Approved Vendors (wherever applicable)	58
11.3.	Dispute Resolution Mechanism (Clause No. 18 of GCC)	59
11.4.	List of Applicable Laws and Standards	60
11.5.	Pre-Bid Meeting Minutes (if issued as an addendum)	61
11.6.	Corrigendum/Addendum to RFP (if issued)	62
12.	Information Required to Evaluate the Bid Capacity.....	63
12.1.	Calculation of "A" and "C"	63
12.2.	Calculation of "B"	63
13.	Miscellaneous Provisions	65
13.1.	Force Majeure Clause No. (Clause No. 19 of GCC).....	65
13.2.	Termination Conditions (Clause No. 20 of GCC)	65
13.3.	Governing Law and Jurisdiction.....	68
14.	Undertaking	69
15.	Non-Disclosure Agreement	71
16.	Power of Attorney.....	76
17.	Environmental Management Plan (EMP)	77
18.	List of Annexures	79

National Highways Infra Trust

 National Highways Infra Trust	RFP for Providing Incident Management Vehicles	Doc No.: NHIT/FY25-26/RFP/ Incident Management-02
--	---	--

Disclaimer

The information contained in this Request for Proposal ("RFP") or subsequently provided to Bidder(s), in documentary or any other form, by or on behalf of **NHIT**, or by any authorized person(s), is provided to the interested parties on the terms and conditions set out in this RFP and any other terms and conditions under which such information is provided.

This RFP is not an agreement, offer, or invitation by **NHIT** to any interested parties. Its purpose is solely to provide Bidders with relevant information to assist them in preparing and submitting their proposals ("Proposal" or "Bid") for selection as a vendor for **NHIT** under the specified norms.

NHIT makes no representation or warranty and shall not be liable to any Bidder or other person to the fullest extent permissible under applicable laws for any loss, damage, cost, or expense arising from reliance on this RFP or any related process. This includes any inaccuracies, omissions, assumptions, or assessments made based on the information provided.

Each Bidder warrants that the information it provides to **NHIT** in its Proposal and during the bidding process is accurate and complete to the best of its knowledge and belief. The Bidder further indemnifies and holds **NHIT** harmless from any claims, liabilities, or expenses arising from errors, defaults, or non-compliance with applicable laws by the Bidder, including the submission of inaccurate statutory forms or documents.

The issuance of this RFP does not commit **NHIT** to accept any Proposal, award any contract, or enter into any agreement. **NHIT** reserves the right to amend, modify, or annul the bidding process at any time prior to the issuance of a Letter of Award/Work Order, without incurring any liability or obligation to any Bidder.

NHIT reserves the right to withdraw, cancel, or terminate this RFP process at any stage, including after the receipt of Proposals, without assigning any reason and without any obligation to proceed with the tender. In the event that no contract is awarded, **NHIT** shall not be liable for any claims, expenses, or losses incurred by any Bidder in connection with the preparation and submission of their Proposal. Bidders shall have no right to seek any form of relief, compensation, or damages from **NHIT**, whether in contract, tort, or otherwise, in relation to the cancellation or non-award of this RFP.

All costs associated with the preparation and submission of Proposals, including any demonstrations, presentations, or related expenses, shall be borne solely by the Bidder. Under no circumstances shall **NHIT** be liable for such costs, regardless of the conduct or outcome of this RFP process.

National Highways Infra Trust

 National Highways Infra Trust	RFP for Providing Incident Management Vehicles	Doc No.: NHIT/FY25-26/RFP/ Incident Management-02
--	---	--

1. Invitation for Bids (IFB)

1.1. Brief Overview of the Work under Consideration

The scope and details of the work under consideration are provided in the Contract Data Sheet. Bidders are advised to refer to it for further information.

1.2. Key Dates

The key dates related to this RFP, including submission deadlines and evaluation timelines, and their respective locations and modes, are provided in the Contract Data Sheet. Bidders are advised to refer to it for further information.

Event Description	Date & Time	Location / Mode
Invitation of RFP		
Last date of Receiving Queries / Clarifications		
Pre-Bid Meeting date		
Pre-Bid meeting Venue		
Client's response to queries / Clarifications		
Last date of Bid Submission		
Physical Submission of Bid Security / POA etc.		
Opening of Technical Bid		
Declaration of Eligible / Qualified bidders		
Opening of Financial Bid		
Letter of Award		
Validity of bids		
Signing of Agreement		

1.3. Eligibility Criteria (Summary)

The eligibility criteria for this bid are specified in Clause 3 (Eligibility and Qualification Criteria) of this RFP. Bidders are required to meet all the technical, financial, and legal requirements outlined therein.

For complete details, bidders must refer to Clause 3.

1.4. Contact Information

Contact Person	Designation	Contact Number	Email Address

In case of any change in the Contractor's contact details, constitution, or organizational hierarchy, they shall immediately notify the Client.

National Highways Infra Trust

 National Highways Infra Trust	RFP for Providing Incident Management Vehicles	Doc No.: NHIT/FY25-26/RFP/ Incident Management-02
--	---	---

2. Instructions to Bidders (ITB)

2.1. Definitions and Interpretations

The following terms, unless repugnant to the context, shall have the meanings assigned hereunder. All definitions are listed alphabetically:

Term	Definition
Addendum	shall mean any written clarification, revision, amendment, or modification issued by the Client to the RFP before the bid submission deadline , which forms an integral part of the RFP document . An Addendum is intended to address queries, provide additional information, or make necessary changes to the bidding requirements, and all Bidders shall be required to consider it in their Bid submissions.
Agreement	Shall mean the legally binding contract executed between the Client and the Contractor for providing services related to road construction and maintenance projects. It includes the General Conditions of Contract (GCC), Special Conditions of Contract (SCC), Annexures, Letter of Award (LoA), schedules, and any mutually agreed amendments or modifications. The Agreement defines the roles, responsibilities, deliverables, timelines, and performance standards expected of the Contractor and governs the contractual relationship between the parties in accordance with applicable laws, regulations, and standards, including those specified by the Ministry of Road Transport and Highways (MoRTH) and other relevant authorities.
Annexures	shall mean the documents, schedules, drawings, specifications, and any other supplementary material attached to or referenced in this RFP. These Annexures form an integral part of the RFP and, once the Contract is awarded, shall be binding on the Contractor.
Authority	Shall mean the National Highways Authority of India (NHAI) or its authorized representative.
Bank Guarantee	Shall mean a written guarantee issued by a bank, on behalf of the Contractor, to secure the performance or payment obligations under the contract, ensuring that the bank will fulfil the financial commitments in the event of the Contractor's failure to perform as per the terms and conditions of the contract.
Bid	shall mean the formal offer submitted by a Bidder in response to the Request for Proposal (RFP), comprising all required documents, technical and financial proposals, declarations, and any other information stipulated in the bidding documents. A Bid represents the Bidder's commitment to execute the works or services as per the terms, conditions, and specifications outlined in the Contract, subject to acceptance by NHIT.
Bid Due Date	Shall mean the last date and time specified for submission of Bids in the RFP.
Bid Security	shall mean the financial guarantee furnished by a Bidder in the form of a Bank Guarantee, Demand Draft, or any other approved instrument , as specified in the RFP, to secure the Bidder's commitment to the bidding process. It ensures that the Bid remains valid and that the Bidder complies

National Highways Infra Trust

	RFP for Providing Incident Management Vehicles	Doc No.: NHIT/FY25-26/RFP/ Incident Management-02
---	---	--

Term	Definition
	with all requirements outlined in the bidding documents. The terms governing the submission, validity, and forfeiture of the Bid Security shall be as stipulated in the RFP and Contract.
Bidder	shall mean any individual, firm, company, joint venture (JV), or consortium that submits a Bid in response to the Request for Proposal (RFP). The Bidder must meet the eligibility criteria specified in the RFP and shall be responsible for complying with all terms, conditions, and obligations outlined in the bidding documents.
Bidding Process	shall mean the entire sequence of activities undertaken by NHIT for the selection of a Contractor, Supplier, or Service Provider, starting from the issuance of the Request for Proposal (RFP) until the final award of the Contract. This includes, but is not limited to, the issuance of bidding documents, pre-bid meetings, submission and evaluation of bids, clarifications, negotiations (if applicable), selection of the successful bidder, and issuance of the Letter of Award (LOA).
Client / Employer	Shall refer to NHIT and its subsidiaries, incorporated under the Companies Act, along with their legal successors, assignees, and authorized officers, who are entitled to the rights and remedies as outlined in the Contract.
Confidential / Confidentiality	<p>shall mean any information, document, data, or communication, whether disclosed in writing, verbally, electronically, or by any other means, that is designated as confidential or that, by its nature, should reasonably be considered confidential. This includes, but is not limited to, technical data, trade secrets, financial information, proprietary methodologies, business strategies, project details, and any information shared during the bidding or contract execution process.</p> <p>Confidentiality requires that such information shall not be disclosed, reproduced, shared, or used for any purpose other than its intended use under the Contract, except with the prior written consent of the Client or as required by law. The obligation of confidentiality shall remain in effect throughout the bidding process, contract duration, and for a specified period thereafter, as defined in the Contract.</p>
Construction Works	<p>shall mean all activities covered under this Contract, including Road Construction, Periodic Maintenance, Routine Maintenance, Electrical Works, and Electrical Maintenance. It encompasses the development, widening, strengthening, and new construction of highways, bridges, culverts, embankments, and associated infrastructure. It also includes periodic maintenance activities such as resurfacing, overlays, rejuvenation treatments, and structural rehabilitation to ensure the longevity of road assets. Routine maintenance obligations, including pothole patching, crack sealing, drainage cleaning, shoulder repairs, and signage upkeep, form an integral part of Construction Works to maintain operational efficiency and road safety.</p> <p>Additionally, Construction Works extend to electrical infrastructure, covering the installation, testing, commissioning, servicing, and maintenance of</p>

National Highways Infra Trust

 <p>NHIT National Highways Infra Trust</p>	RFP for Providing Incident Management Vehicles	Doc No.: NHIT/FY25-26/RFP/ Incident Management-02
---	---	---

Term	Definition
	<p>street lighting systems, transformers, power supply networks, and associated electrical components to ensure continuous functionality. For the purposes of this RFP, Construction Works shall exclude ATMS (Advanced Traffic Management System) and TMS (Traffic Management System), which shall be governed under a separate contractual framework.</p>
Contract	<p>shall mean the legally binding agreement executed between NHIT and the selected Contractor for the execution of works, supply of goods, or provision of services as specified in the bidding documents. The Contract shall include the Letter of Award (LOA), General Conditions of Contract (GCC), Special Conditions of Contract (SCC), Contract Data, Scope of Work, Technical Specifications, Bill of Quantities (BoQ), and any other documents forming part of the agreement, along with all amendments, addendums, and modifications issued thereafter.</p>
Contract Price	<p>shall mean the total amount payable to the Contractor by NHIT for the execution of the works, supply of goods, or provision of services as specified in the Contract. The Contract Price shall be as stated in the Letter of Award (LOA) and shall be subject to adjustments, variations, deductions, or additions in accordance with the terms and conditions of the Contract, including approved change orders, price variations, and applicable taxes as per the governing law.</p>
Contractor	<p>shall mean the Successful Bidder to whom the Contract has been awarded by NHIT for the execution of the works, supply of goods, or provision of services as per the terms and conditions of the Contract. The term shall include the Contractor's legal successors, permitted assigns, subcontractors, or agents engaged in the performance of the Contract, subject to the approval of NHIT where required.</p>
Day	<p>Shall mean a calendar day unless otherwise specified.</p>
Default	<p>shall mean any failure, omission, or non-performance by the Contractor in fulfilling its contractual obligations, whether due to negligence, wilful misconduct, or inability to comply with the terms and conditions of the Contract. This includes, but is not limited to, failure to execute the works as per agreed specifications and timelines, non-compliance with statutory and regulatory requirements, defective or substandard work, breach of financial obligations, or any act that compromises the safety, quality, or serviceability of the road construction and maintenance works.</p>
Defect Liability Period	<p>shall mean the specified period commencing from the date of completion and acceptance of the works by NHIT, during which the Contractor is responsible for rectifying any defects, deficiencies, or faults arising due to defective materials, workmanship, or non-compliance with the Contract specifications. The Contractor shall carry out all necessary repairs, replacements, or corrections at no additional cost to NHIT within the timeframe stipulated in the Contract. The Defect Liability Period shall be as</p>

National Highways Infra Trust

 <p>NHIT National Highways Infra Trust</p>	RFP for Providing Incident Management Vehicles	Doc No.: NHIT/FY25-26/RFP/ Incident Management-02
---	---	---

Term	Definition
	specified in the Contract Data and may be extended in case of delayed rectification or repeated defects.
Dispute	Dispute" shall mean any disagreement, conflict, claim, controversy, or difference of opinion arising between the Contractor and NHIT in connection with the interpretation, execution, performance, or enforcement of the Contract. This includes, but is not limited to, disputes related to scope of work, quality of execution, contractual obligations, payment issues, delays, penalties, variations, termination, or any other matter affecting the rights and obligations of the parties under the Contract.
Draft Contract Agreement	shall mean the preliminary version of the contractual document included in the RFP, which outlines the terms, conditions, obligations, rights, and responsibilities of both the Client and the Successful Bidder. The Draft Contract Agreement serves as the base document for finalizing the formal contract, subject to modifications, negotiations (if applicable), and execution upon award of the Contract.
Eligible Bidder	shall mean an individual, firm, company, joint venture (JV), or consortium that meets the eligibility criteria specified in the RFP, including but not limited to technical qualifications, financial capacity, legal compliance, and past experience. The Bidder must not be debarred, blacklisted, or disqualified by any government authority, regulatory body, NHA, NHIT, or its subsidiaries. An Eligible Bidder shall comply with all requirements outlined in the bidding documents and shall be legally capable of entering into a contract with NHIT.
Letter of Acceptance (LoA)	shall mean the formal written communication issued by NHIT to the Successful Bidder , confirming the acceptance of their bid and awarding the Contract, subject to the fulfilment of any preconditions specified therein. The LOA shall constitute a binding commitment between NHIT and the Successful Bidder, requiring the execution of the formal Contract Agreement within the stipulated time. The issuance of the LOA does not, by itself, create a right to commence work unless expressly stated in the document.
Lowest Responsive Bid	shall mean the bid that offers the lowest price among those determined to be Responsive Bids , meeting all eligibility, technical, and financial criteria outlined in the RFP. The bid must also fulfil the qualification requirements specified in Clause 3 , ensuring that the bidder has the necessary technical capability, resources, and financial strength to execute the contract successfully. The determination of the Lowest Responsive Bid shall be made based on both price competitiveness and compliance with the overall workability and feasibility requirements set forth in the RFP.
Material Litigation	shall mean any legal dispute, claim, arbitration, or proceeding—whether pending, resolved, or threatened—that has or may have a significant impact on the Bidder's financial stability, technical capability, or ability to perform contractual obligations . Material Litigation includes cases where the claimed or potential liability exceeds a specified threshold (e.g., 10% of the Bidder's net worth or turnover , as defined in the RFP) or where the

National Highways Infra Trust

 <p>NHIT National Highways Infra Trust</p>	<p>RFP for Providing Incident Management Vehicles</p>	<p>Doc No.: NHIT/FY25-26/RFP/ Incident Management-02</p>
---	--	---

Term	Definition
<p>NHIT</p>	<p>outcome could materially affect the Bidder’s credibility, resources, or legal standing in contract execution.</p> <p>"National Highways Infra Trust (NHIT)" shall mean an irrevocable infrastructure trust set up by the National Highways Authority of India (NHAI) under the provisions of the Indian Trusts Act, 1882, and registered as an Infrastructure Investment Trust (InvIT) under the Securities and Exchange Board of India (Infrastructure Investment Trusts) Regulations, 2014 (SEBI InvIT Regulations) with registration number IN/InvIT/20-21/0014.</p> <p>NHIT, along with its Special Purpose Vehicles (SPVs) and subsidiaries, acts as the Client/Employer in this RFP and subsequent Contract. It is responsible for the development, operation, maintenance, and management of highway infrastructure projects and shall exercise all rights, obligations, and authority as specified in the bidding documents and the Contract.</p> <p>Wherever "NHIT" is mentioned in this RFP or the Contract, it shall be deemed to include NHIT, its SPVs, and its subsidiaries, all of whom shall act as the Client/Employer for the purposes of this agreement.</p>
<p>Notice to Proceed</p>	<p>shall mean the formal written instruction issued by the Client to the Contractor, authorizing the commencement of work in accordance with the terms, conditions, and timelines specified in the Contract. The issuance of the Notice to Proceed marks the official start of the Contractor’s obligations under the Contract.</p>
<p>Overlapping Constituents</p>	<p>shall mean any situation where two or more Bidders share common ownership, management, key personnel, shareholders, parent companies, subsidiaries, affiliates, or any other controlling interests that may compromise the fairness, competitiveness, or integrity of the bidding process. This includes but is not limited to instances where entities have direct or indirect influence over each other’s bidding decisions, access to each other’s confidential information, or any arrangement that creates a conflict of interest.</p>
<p>Procuring Authority</p>	<p>shall mean the designated department, division, or official(s) within NHIT responsible for overseeing the procurement process, issuing the RFP, evaluating bids, and awarding contracts. This may include, but is not limited to, NHIT’s Procurement Department, Project Department, or any other authorized entity delegated with such responsibilities under this RFP.</p>
<p>RFP</p>	<p>shall mean the official bidding document issued by the Client to invite proposals from eligible Bidders for the execution of specified works or services. The RFP includes all amendments, Addendum, Annexures, appendices, clarifications, and any other documents provided by the Client during the bidding process. It outlines the scope of work, eligibility criteria, bidding procedures, evaluation parameters, and contractual terms, serving as the foundation for bid preparation and contract formation.</p>
<p>Scope of Work</p>	<p>shall mean the comprehensive description of all activities, tasks, responsibilities, and deliverables that the Contractor is required to perform</p>

National Highways Infra Trust

	RFP for Providing Incident Management Vehicles	Doc No.: NHIT/FY25-26/RFP/ Incident Management-02
---	---	--

Term	Definition
	<p>under the Contract. It includes, but is not limited to, the technical specifications, performance requirements, quality standards, timelines, and compliance obligations as defined in the RFP and its associated documents. The Scope of Work establishes the contractual expectations, execution methodology, and measurable outcomes for the successful completion of the project.</p>
Statutory Auditor	<p>shall mean a Chartered Accountant (CA) who is legally authorized and appointed under applicable laws and regulations to conduct statutory audits, financial verifications, and compliance assessments as required by governing authorities. A Statutory Chartered Accountant is responsible for certifying financial statements, ensuring regulatory compliance, and providing independent assurance on the financial health and operations of an entity. Their appointment, role, and responsibilities shall be in accordance with the applicable statutory provisions, including but not limited to the Companies Act, Income Tax Act, or any other relevant financial regulations.</p>
Statutory Chartered Accountant	<p>shall mean a Chartered Accountant (CA) who is legally authorized and appointed under applicable laws and regulations to conduct statutory audits, financial verifications, and compliance assessments as required by governing authorities. A Statutory Chartered Accountant is responsible for certifying financial statements, ensuring regulatory compliance, and providing independent assurance on the financial health and operations of an entity. Their appointment, role, and responsibilities shall be in accordance with the applicable statutory provisions, including but not limited to the Companies Act, Income Tax Act, or any other relevant financial regulations.</p>
Responsive Bid	<p>shall mean a bid that complies in all material aspects with the eligibility criteria, technical requirements, specifications, terms, and conditions of the Request for Proposal (RFP). A Responsive Bid must meet the submission requirements, including the correct form and format, and must not contain any material deviations or omissions.</p>
Successful Bidder	<p>shall mean the Bidder whose proposal has been evaluated as the most responsive and compliant with the requirements set forth in the RFP and has been formally accepted by the Client for the award of the Contract. The Successful Bidder is the entity that has met all technical, financial, and eligibility criteria and has been issued the Letter of Acceptance (LOA) or any other official communication confirming the contract award.</p>
Technical Proposal	<p>Shall mean the section of the Bid submitted by a Bidder that provides a detailed description of their technical approach, methodology, and plan for executing the Work. It includes but not limited to the information on the resources, timeline, and technical expertise to be applied in the project.</p>
Terms of Reference (ToR)	<p>shall mean the comprehensive framework outlining the objectives, scope, methodology, deliverables, performance standards, and reporting requirements that the Contractor must adhere to under the Contract. It</p>

National Highways Infra Trust

 National Highways Infra Trust	RFP for Providing Incident Management Vehicles	Doc No.: NHIT/FY25-26/RFP/ Incident Management-02
--	---	--

Term	Definition
	defines the roles, responsibilities, and expectations of all stakeholders, ensuring alignment with technical, quality, compliance, and regulatory requirements as specified in the RFP and associated documents.
Work	Shall mean all activities, services, and deliverables to be performed by the Contractor as specified in the RFP. This includes, but is not limited to, the execution of tasks, provision of resources, and fulfilment of requirements outlined in the Scope of Work, regardless of the specific nature of the project.
Written Communication	Shall mean any correspondence exchanged in writing, which includes, but is not limited to, letters, emails, notices, memos, and any other forms of written documentation used for communication between the Client and the Contractor or among parties involved in the project.

2.2. Instructions to Bidders – General Instructions

2.2.1. Submission of Bids – Individual, Joint Venture or Consortium (Refer clause 5.3 of CDS)

2.2.1.1. Prohibition on Multiple Bid Submissions

A bidder shall submit only one bid for the same project, either as an individual entity or as part of a Joint Venture (JV) or Consortium, but not in both capacities.

A bidder participating as a member of a JV or Consortium shall not submit a separate bid as an individual entity or as a member of another JV/Consortium for the same project.

Any violation of this provision shall lead to immediate disqualification of all bids submitted by the bidder in any form.

2.2.1.2. Joint Venture and Consortium Participation

Bidders may form **Joint Ventures (JVs) or Consortia** to submit bids, provided that:

- i. The JV/Consortium **appoints a Lead Member**, who shall be responsible for contractual obligations.
- ii. The members of the JV/Consortium **jointly and severally undertake** to fulfil the contract.
- iii. The composition of the JV/Consortium **shall not be altered** without prior approval from NHIT.

2.2.1.3. Declaration of Agreements and Responsibilities

- i. All members of the JV/Consortium **must submit a legally binding agreement**, defining their roles, responsibilities, and financial commitments.
- ii. NHIT **reserves the right to request additional documentation** or conduct due diligence to verify the independence and capability of the bidding entities.

2.2.1.4. Restrictions on Subcontracting

- i. While JVs and Consortia are permitted, **subcontracting key project obligations** to external entities **without prior approval** from NHIT shall not be allowed.

National Highways Infra Trust

 <p>NHIT National Highways Infra Trust</p>	<p>RFP for Providing Incident Management Vehicles</p>	<p>Doc No.: NHIT/FY25-26/RFP/ Incident Management-02</p>
---	--	---

- ii. NHIT reserves the right to reject bids where subcontracting arrangements **undermine the bidder's core responsibilities**.

2.2.1.5. Disqualification for Non-Compliance

- i. Any bid **violating these provisions**—such as multiple submissions from the same entity under different capacities—**shall be rejected**.
- ii. Any false or misleading information regarding the JV/Consortium structure shall lead to **disqualification and possible legal action** by NHIT.

2.2.2. Power of Attorney (PoA) for Bidders

2.2.2.1. Requirement for PoA Submission

All bidders, whether **domestic (national) or international**, and whether **submitting bids individually, as part of a Joint Venture (JV), or as a Consortium**, must provide a **valid Power of Attorney (PoA)** authorizing the signatory to represent the bidder in all matters related to the submission of the bid and the execution of the contract if awarded.

2.2.2.2. Compliance with Local and Indian Laws

- i. The PoA should **adhere to the legal formalities and requirements of both the bidder's home country and India** to ensure its **validity and enforceability in legal proceedings**.
- ii. It must be prepared and validated in a manner that aligns with the **legal framework and authorities of the bidder's home country** and must be **duly recognized under Indian law** to be considered valid for the bidding process.

2.2.2.3. Attestation & Notarization Requirements

- i. If issued outside India, the PoA must be **duly notarized and attested by the appropriate authority**, including **consular authentication** where required, to ensure enforceability in India.
- ii. If issued within India, the PoA must be **executed on a non-judicial stamp paper of appropriate value** and duly notarized.

2.2.2.4. Reference for Other Clauses

Any requirement related to the authorization of the bidder's representative, legal authority, or signature verification in other sub-clauses shall **refer to this clause (2.2.2)** instead of repeating PoA requirements.

2.2.2.5. Non-Compliance & Disqualification

Failure to submit a valid PoA **as per the above requirements** shall result in **disqualification of the bidder or consortium** from the bidding process.

- 2.2.3. Notwithstanding anything to the contrary contained in this RFP, the detailed terms and conditions specified in the agreement, including but not limited to the General Conditions of Contract (GCC), Special Conditions of Contract (SCC), Contract Data, Terms of Reference, Particular Conditions of Contract, Bill of Quantities (BoQ), and any other contract-related documents, shall have an overriding effect. In the event of any conflict or inconsistency between the terms in the RFP and those in the agreement, the provisions of the agreement shall prevail, unless specifically mentioned in the LOA. Any amendments or modifications to these terms shall be mutually agreed upon by the Client and the Contractor in writing.

National Highways Infra Trust

 <p>NHIT National Highways Infra Trust</p>	<p>RFP for Providing Incident Management Vehicles</p>	<p>Doc No.: NHIT/FY25-26/RFP/ Incident Management-02</p>
---	--	---

2.2.4. Conflict of Interest

- 2.2.4.1.** Bidders shall at all times provide professional, objective, and impartial advice, prioritizing the interests of the NHIT Entities above all else. Bidders must avoid conflicts with other assignments or their own corporate interests, ensuring their actions are free from any considerations of future work opportunities. Under no circumstances shall two Bidders have **overlapping constituents**, nor shall any arrangement exist whereby a third-party gains access to the confidential information of another Bidder.
- 2.2.4.2.** Bidders must sign a Non-Disclosure Agreement (NDA) with NHIT post issuance of the Letter of Award (LOA), should NHIT deem it necessary.
- 2.2.4.3.** Bidders are required to disclose any existing relationships or engagements with NHIT, its affiliates, or other stakeholders that could potentially lead to a conflict of interest. Such disclosures must be made in writing at the time of bid submission and updated promptly if any changes occur during the bidding process or execution of the contract.
- 2.2.4.4.** Any conflict of interest discovered during the execution of the contract must be immediately reported to NHIT. Failure to disclose such conflicts may result in penalties, including termination of the contract and disqualification from future bidding processes.
- 2.2.4.5.** Bidders must implement robust internal controls to ensure compliance with this clause, including measures to prevent unauthorized access to confidential information and to maintain the integrity of the bidding process.
- 2.2.4.6.** NHIT reserves the right to audit the Bidders' practices and processes to verify compliance with the conflict-of-interest provisions outlined in this clause. Non-compliance identified during such audits may attract sanctions as deemed appropriate by NHIT.

2.2.5. Fraud & Corruption

- 2.2.5.1.** Bidders shall observe the highest standard of ethics during the selection process and throughout the execution of the work. For the purposes of this clause, **NHIT** defines:
- 2.2.5.1.1. **Corrupt Practice:** The offering, giving, receiving, or soliciting of anything of value to influence the action of a public official in the selection process or during contract execution.
- 2.2.5.1.2. **Fraudulent Practice:** Any act of misrepresentation or false declaration of facts intended to influence the selection process or execution of a contract to the detriment of **NHIT**. This includes collusive practices among bidders, whether prior to or after submission of proposals, aimed at depriving **NHIT** of the benefits of fair and open competition.
- 2.2.5.2.** **NHIT** reserves the right to reject any proposal if it determines that the bidder recommended for selection has engaged in corrupt or fraudulent practices during the bidding process.
- 2.2.5.3.** **NHIT** may declare a bidder ineligible to participate in any future procurement processes, either indefinitely or for a specified duration, if it determines at any time that the bidder has engaged in corrupt or fraudulent practices.
- 2.2.5.4.** Bidders declared ineligible for corrupt or fraudulent practices under this clause shall be prohibited from participating in the selection process for any work or services tendered by **NHIT** during the specified period of ineligibility.
- 2.2.5.5.** Any instances of corrupt or fraudulent practices discovered during contract execution shall result in immediate termination of the contract, forfeiture of any performance guarantees, and potential legal action as deemed appropriate by **NHIT**.

National Highways Infra Trust

 <p>NHIT National Highways Infra Trust</p>	<p>RFP for Providing Incident Management Vehicles</p>	<p>Doc No.: NHIT/FY25-26/RFP/ Incident Management-02</p>
---	--	---

2.2.5.6. NHIT reserves the right to conduct audits or investigations to ensure compliance with this clause. Bidders must cooperate fully with such audits or investigations, providing access to all relevant records, documents, and personnel.

2.2.5.7. Bidders are required to include a written declaration as part of their proposal, confirming that they have not engaged in and will not engage in any corrupt or fraudulent practices as defined in this clause. Non-compliance with this declaration may result in disqualification.

2.2.5.8. NHIT reserves the right to share information regarding ineligible bidders with other public entities or organizations to promote transparency and accountability.

2.2.5.9. Any breach of this clause shall entitle **NHIT** to recover any damages incurred due to the corrupt or fraudulent practices, in addition to other remedies available under applicable law.

2.2.6. Termination of RFP Process

2.2.6.1. The Procuring Authority reserves the right to terminate the RFP process at any stage without assigning any reason and without incurring any liability to the bidders, including but not limited to costs or expenses incurred in the preparation or submission of proposals.

2.2.6.2. Such termination may occur under, but is not limited to, the following circumstances:

- a) Significant changes in the scope, objectives, or requirements of the project that necessitate re-evaluation of the procurement approach.
- b) Non-compliance with applicable laws, regulations, or internal policies during the RFP process.
- c) Insufficient or inadequate responses received that do not meet the minimum qualification criteria or technical specifications outlined in the RFP.
- d) Detection of fraudulent practices, misrepresentation, or conflict of interest among any participating bidders.
- e) Budgetary constraints or unavailability of funds.
- f) Force Majeure events or other unforeseen circumstances that make the continuation of the RFP process impracticable.

2.2.6.3. In the event of termination, the Procuring Authority shall publish a notification regarding such termination on the official NHIT website. It shall be the sole responsibility of the bidders to stay informed of any updates or changes. The Procuring Authority shall not be liable for any claims arising due to a bidder's failure to take note of such publication. The Procuring Authority may, at its discretion, issue a new RFP for the same or substantially similar scope of work.

2.2.6.4. The Procuring Authority shall not be obligated to provide reasons for the termination of the RFP process or to disclose any internal evaluations, decisions, or deliberations related to the termination.

2.2.6.5. The termination of the RFP process shall not confer any rights upon any bidder or entity, nor shall it result in any claim or cause of action against the Procuring Authority or its representatives.

2.2.6.6. This clause is independent of any termination provisions applicable to the subsequent contract, which shall be governed by the terms of the General Conditions of Contract (GCC) or Special Conditions of Contract (SCC).

2.2.7. Bid Capacity

2.2.7.1. Qualification Based on Bid Capacity:

National Highways Infra Trust

 <p>NHIT National Highways Infra Trust</p>	<p>RFP for Providing Incident Management Vehicles</p>	<p>Doc No.: NHIT/FY25-26/RFP/ Incident Management-02</p>
--	--	---

Bidders meeting the minimum qualification criteria outlined in this RFP shall qualify only if their assessed available bid capacity exceeds the estimated bid value of INR 40 crores (for calculation purposes only; this figure does not reflect the actual bid value). The available bid capacity shall be determined as follows:

$$\text{Assessed Available Bid Capacity} = (A \times N \times 2.5) - B + C$$

Where:

A = Maximum value of civil engineering works excluding the amount of bonus received, if any, in respect of EPC Projects executed in any one year during the last three years (updated to the price level of the year indicated in table at Note-3 below) taking into account the completed as well as works in progress. The EPC projects include turnkey projects/ Item rate contract/ Construction works.

N = Duration (in years) specified for completion of the works under this RFP.

B = Value (updated to the price level of the year indicated in table at **Notes for Calculation** below) of existing commitments, works for which the bidder has emerged as the winner of the bids or on-going work to be completed during the period of completion of the works for which BID is invited. For the sake of clarification, it is mentioned that works for which bidder has emerged as the winner of the bids, but LOA has not been issued as on the day before opening the financial bids shall also be considered while calculating value of B.

C = The amount of bonus received, if any, in EPC Projects during the last 3 years (updated to the price level of the year indicated in table at Notes for Calculation below).

2.2.7.2. Notes for Calculation:

2.2.7.2.1. Price Level Adjustment Factors:

The following factors shall be used to update the annual turnover and commitments to the current price level:

Year	Year-1 (Current Financial Year)	Year-2 (Previous Year)	Year-3 (Two Years Prior)
Updation Factor	1.00	1.05	1.10

Year-1: Refers to the current financial year or, if the bid due date falls within three months of the close of the last financial year, the preceding financial year.

Year-2 and Year-3: Refer to the financial years immediately preceding Year-1.

2.2.7.3. Verification of Commitments:

The bidder must submit a statement detailing all current commitments, including ongoing works and works for which the bidder has been declared the winner but not yet issued an LOA. This statement must include the following details for each work:

- i. Name of work.
- ii. Value of the contract (updated to current price levels as per Note 1).
- iii. Stipulated completion period and remaining completion timeline.

The statement must be:

National Highways Infra Trust

 <p>NHIT National Highways Infra Trust</p>	RFP for Providing Incident Management Vehicles	Doc No.: NHIT/FY25-26/RFP/ Incident Management-02
---	---	--

- i. Countersigned by the Engineer-in-Charge (not below the rank of Executive Engineer) for EPC projects or by the Concessionaire/Authorized Signatory of the SPV for BOT projects.
- ii. Verified and certified by the bidder's Statutory Auditor.

Failure to submit the required statement or submission of an incomplete or unverified statement shall result in disqualification of the bid as per Clause 3 (Eligibility and Qualification Criteria).

2.2.7.4. General Provisions:

- i. Bidders shall submit the required details for the calculation of 'A' and 'C' in the prescribed format as provided in the Annexure of this document. Failure to furnish these details in the specified format shall render the bid non-compliant and subject to disqualification.
- ii. Bidders must ensure accurate and complete disclosure of commitments and turnover figures. Any misrepresentation or omission may result in disqualification.
- iii. NHIT reserves the right to seek additional clarifications or conduct independent verification of the submitted data.
- iv. This bid capacity assessment is non-negotiable and binding for all bidders participating in this RFP process.
- v. The amount of bonus received, if any, in EPC Projects should be countersigned by the Client or its Engineer-in-charge not below the rank of Executive Engineer or equivalent in respect of EPC Projects.

2.2.8. Earnest Money Deposit (EMD)

The Bidder is required to submit an Earnest Money Deposit (EMD) as part of the bid security. **All provisions related to EMD, including its amount, mode of submission, validity, refund conditions, and forfeiture, are specified under Clause 2.4 (Bid Security Details).** Bidders are required to comply with the provisions mentioned therein.

2.2.9. Key Terms and Conditions of Appointment/Engagement

2.2.9.1. Right to Modify Validity Period: NHIT reserves the absolute right to either curtail or extend the validity period of the engagement/appointment of the appointed Agency/Firm, at its sole discretion, as deemed necessary for the successful execution of the project or in the best interest of NHIT. Any extension or reduction in the validity period will be communicated to the Agency/Firm in writing.

2.2.9.2. Notification of Changes: In case of any modification to the validity period, NHIT will provide written notice specifying the new terms and conditions, including the extended or shortened period, and any associated adjustments, if applicable.

2.2.9.3. Obligations During Extension or Curtailment: The appointed Agency/Firm shall continue to fulfil all obligations under this engagement, including performance deliverables, timelines, and other agreed-upon terms, during the entire extended or curtailed period, unless otherwise notified by NHIT.

2.2.9.4. Contractor's Obligations Upon Termination

- i. In the event of termination under the provisions of the **Termination of Contract clause in the GCC**, the Contractor shall continue to perform all contractual obligations diligently until the effective date of termination, as specified in the termination notice. The Contractor shall not:
 - a) unilaterally cease work before the termination date.

National Highways Infra Trust

 <p>NHIT National Highways Infra Trust</p>	<p>RFP for Providing Incident Management Vehicles</p>	<p>Doc No.: NHIT/FY25-26/RFP/ Incident Management-02</p>
---	--	---

- b) obstruct or interfere with other agencies executing parallel works; or
- c) damage, disrupt, or delay any ongoing or completed work.
- ii. The Contractor shall ensure a smooth handover of the site, including all relevant documents, materials, and work records, in coordination with the Client and any succeeding agency. Failure to comply with these obligations shall be treated as a **breach of contract**, entitling the Client to impose penalties, recover damages, forfeit performance security, or take any other legal action deemed necessary.
- iii. The Client reserves the right to blacklist the Contractor from future projects for a specified period in the event of non-compliance with this clause.

2.2.9.5. No Claims for Extension or Curtailment: The appointed Agency/Firm acknowledges and agrees that there shall be no entitlement to any claim or compensation in connection with any extension or reduction in the engagement period, unless explicitly agreed upon by both parties in writing.

2.2.10. MSME Status of Agency/Firm

2.2.10.1. Confirmation of MSME Status: The Bidder shall confirm whether it is registered as a **Micro Enterprise, Small Enterprise, or Medium Enterprise** under the relevant laws and regulations governing MSMEs. The Bidder shall submit their **Registration Number** along with a copy of the **Registration Certificate** issued by the appropriate authority.

2.2.10.2. Notification of Change in Status: The Bidder agrees to notify **NHIT** promptly in writing of any change in the status of their organization with respect to the classification under the **Micro, Small, and Medium Enterprises (MSME) Development Act** or any other relevant legislation. This includes, but is not limited to, any changes that may affect their eligibility for MSME benefits or status.

2.2.10.3. Responsibility for Non-Notification: The Bidder acknowledges that it shall be solely responsible for any failure to inform **NHIT** of any change in its MSME status. **NHIT** will not be held liable for any consequences arising from the Bidder's failure to update its status in a timely and accurate manner.

2.2.10.4. Obligation to Provide Updated Documentation: In the event of any change in the Bidder's MSME status, the Bidder shall promptly submit the updated **Registration Certificate** or any other relevant documentation to **NHIT** for verification.

2.2.10.5. Impact on Contractual Obligations: The Bidder understands that failure to comply with the above requirements may result in the disqualification of their bid or termination of any contract awarded, as determined by **NHIT** in its sole discretion.

2.2.11. Indemnification

The Agency shall indemnify, defend, and hold **NHIT** harmless, including its affiliates, directors, officers, employees, agents, and representatives, from and against any and all claims, demands, penalties, fines, losses, damages, costs, expenses, or proceedings (whether actual or threatened), including but not limited to legal fees and expenses, arising directly or indirectly from:

2.2.11.1. Breach of Laws or Regulations: Any breach or contravention of any applicable laws, statutes, regulations, or governmental directives, whether local, national, or international, by the Agency or its personnel during the performance of services under this agreement.

National Highways Infra Trust

 <p>NHIT National Highways Infra Trust</p>	<p>RFP for Providing Incident Management Vehicles</p>	<p>Doc No.: NHIT/FY25-26/RFP/ Incident Management-02</p>
---	--	---

2.2.11.2. Non-compliance: Any failure by the Agency to comply with the terms, conditions, or provisions outlined in this order or agreement.

2.2.11.3. Third-Party Claims: Any claims or actions initiated by third parties, including employees or agents of the Agency, arising from the Agency's negligence, misconduct, or breach of its contractual obligations.

2.2.11.4. Intellectual Property Infringement: Any claims, losses, or damages arising out of infringement or alleged infringement of third-party intellectual property rights, including patents, trademarks, copyrights, or trade secrets, caused by the Agency's actions or omissions.

2.2.11.5. Environmental or Safety Violations: Any penalties, fines, or legal actions arising from violations of environmental laws or safety regulations directly attributable to the Agency's activities.

The indemnity obligations under this clause shall apply irrespective of the negligence, whether active or passive, of **NHIT** or any of its affiliates, and shall survive the termination or expiration of this agreement.

The Agency agrees to assume full responsibility for its actions, or those of its employees, subcontractors, or agents, that result in any of the above-mentioned claims.

2.2.11.6. Indemnification Procedures:

2.2.11.6.1. **Notice of Claim:** In the event that **NHIT** is subject to a claim or proceeding that is subject to indemnification, **NHIT** shall promptly notify the Agency in writing. The Agency shall have the right to assume and control the defense of any such claim or proceeding, at its own expense, provided that **NHIT** may participate in such defense at its own cost and discretion.

2.2.11.6.2. **Cooperation:** **NHIT** agrees to cooperate fully with the Agency in defending or settling any claim subject to indemnification. However, the Agency shall not settle, admit liability, or enter into any agreement or compromise concerning such claims without the prior written consent of **NHIT's** authorized representative, as per **NHIT's** internal approval framework, which may include final approval from the CEO of **NHIT**.

Any settlement that imposes financial obligations, penalties, restrictions, or liabilities on **NHIT** shall be void and unenforceable unless expressly approved in writing by **NHIT**. **NHIT** reserves the right to review, participate in, or assume control of the defense and settlement process at its sole discretion, should it determine that the proposed resolution may adversely impact **NHIT's** legal, financial, or reputational interests.

2.2.11.6.3. **Blacklisting Disclosure & Indemnification**

At any stage of the RFP process, upon award of the contract, during its execution, or at any time before or after completion of contractual obligations, if the Contractor is blacklisted, debarred, or otherwise disqualified from bidding or executing contracts **Central Public Sector Undertaking (CPSU), State Public Sector Undertaking (SPSU), government companies, government organizations, or regulatory authorities, NHA, NHIT and NHIT's subsidiaries**, the Contractor shall immediately notify **NHIT** in writing, providing a detailed explanation of the reasons and circumstances leading to such blacklisting.

Failure to disclose such blacklisting shall be considered a material breach of contract, entitling **NHIT** to take appropriate action, including but not limited to:

- a) Contract termination without liability to **NHIT**,
- b) Forfeiture of performance security,

National Highways Infra Trust

 <p>NHIT National Highways Infra Trust</p>	<p>RFP for Providing Incident Management Vehicles</p>	<p>Doc No.: NHIT/FY25-26/RFP/ Incident Management-02</p>
---	--	---

- c) Recovery of damages resulting from reputational harm, project delays, or financial loss,
- d) Blacklisting the Contractor from future NHIT projects, and
- e) Triggering indemnification provisions to recover any costs incurred due to the Contractor's blacklisting.

NHIT reserves the right to assess the impact of the blacklisting on ongoing contractual obligations and may, at its sole discretion, impose additional safeguards, request alternative arrangements, or initiate necessary legal proceedings to protect its interests

2.2.12. Eligible Bidders

Bidders must meet the eligibility and qualification requirements specified under **Clause 3 (Eligibility & Qualification Criteria)** to participate in the bidding process. The detailed technical, financial, and legal criteria, including the necessary supporting documents, are outlined therein.

2.2.13. Disqualification Criteria

The disqualification conditions applicable to bidders are set forth under **Clause 3.8 (Disqualification Criteria)**. Bidders failing to meet the specified requirements, providing false information, or engaging in prohibited practices shall be disqualified.

2.2.14. Payment Terms

The payment terms for this project are governed by the provisions set forth in the General Conditions of Contract (GCC), Special Conditions of Contract (SCC), and the Contract Data. Bidders are advised to refer to these documents for detailed information regarding the payment schedule, invoicing requirements, and any associated terms.

Key Points:

2.2.14.1. Invoice Submission:

- i. All payments shall be made in accordance with the terms outlined in the Contract, based on the successful submission and approval of invoices by **NHIT**. The required supporting documentation must be provided with each invoice. In case the required documents are not submitted along with the invoice, the payment shall not be disbursed, nor shall the invoice be considered as submitted. An invoice shall only be deemed submitted if it is accompanied by all necessary details and documents required for the verification of its authenticity.

2.2.14.2. Payment Milestones:

- i. Payment will be made in accordance with the approved payment schedule, subject to the successful completion and acceptance of the corresponding milestones, as specified in the Contract Data.

2.2.14.3. Currency and Method of Payment:

- i. Payments will be made in the currency specified in the Contract, through the payment method outlined therein. All payment-related banking charges, if any, shall be borne by the Bidder.

2.2.14.4. Delay in Payment:

National Highways Infra Trust

 <p>NHIT National Highways Infra Trust</p>	<p align="center">RFP for Providing Incident Management Vehicles</p>	<p>Doc No.: NHIT/FY25-26/RFP/ Incident Management-02</p>
--	---	---

- i. In the event of delays in payments due to issues on **NHIT's** part, no interest shall be payable on any overdue payments. The payment will be processed as per the terms outlined in the **General Conditions of Contract (GCC)** and **Special Conditions of Contract (SCC)**.
- ii. Bidders are advised to review the GCC and SCC for the relevant provisions regarding payment timelines and procedures.
- iii. Bidders are advised to review the relevant sections of the GCC, SCC, and Contract Data for a comprehensive understanding of the payment procedures, including any penalties, deductions, or conditions related to payment processing.

2.2.15. Documents to be Submitted Along with the Bid

- i. Bidders are required to submit the following documents as part of their Bid. Failure to provide these documents in the required format may result in disqualification of the Bid:

2.2.15.1. Authorization Documents:

2.2.15.2. Power of Attorney – Refer clause 2.2.2 Bid Form:

- i. The Bid in the form provided in the RFP, duly completed and signed by the authorized representative of the Bidder on all pages.

2.2.15.3. Bidder Profile:

A detailed profile of the Bidder, certified by the Authorized Signatory, including organizational structure, key personnel, and areas of expertise.

2.2.15.4. Eligibility and Experience Documentation:

- i. Documents supporting the Bidder's claims regarding eligibility and experience, duly signed by the authorized representative on all pages.
- ii. Copies of work orders, purchase orders, completion certificates, and performance certificates must be included. **NHIT** reserves the right to request third-party certifications at a later stage.

2.2.15.5. Undertaking:

- i. A declaration or undertaking in the format provided in the RFP, duly signed by the authorized representative on all pages, affirming compliance with the terms and conditions of the RFP.

2.2.15.6. Company Registration and Compliance Certificates:

- i. Copy of the Company Registration Certificate, GST Registration Certificate, and MSME Certificate (if applicable).
- ii. Copies of PAN and TAN registrations (as applicable).
- iii. Any other statutory registration certificates required by law.

2.2.15.7. Experience Credentials:

- i. Experience certificates self-attested by the Authorized Signatory, along with copies of supporting documents such as Work Orders/Purchase Orders and Completion Certificates.

2.2.15.8. Financial Documentation:

- i. Audited financial statements for the last three financial years, including Balance Sheets, Profit and Loss Statements, and Auditor's Reports.

National Highways Infra Trust

 <p>NHIT National Highways Infra Trust</p>	RFP for Providing Incident Management Vehicles	Doc No.: NHIT/FY25-26/RFP/ Incident Management-02
---	---	--

- ii. A Certificate from a Statutory Chartered Accountant specifying the annual turnover of the Bidder for the last three financial years.
- iii. The Bidder shall not have been involved in material litigation that, in aggregate, exceeds 10% of their net worth or annual turnover over the last [5] years. For the purposes of this clause, 'material litigation' refers to any legal dispute, arbitration, or claim that may adversely affect the Bidder's ability to execute the project. The Bidder must provide a declaration of all ongoing and past material litigation, along with supporting documents, if any, for verification by NHIT.

2.2.15.9. Bid Security:

- i. Earnest Money Deposit (EMD) in the form and value specified in the RFP, along with proof of submission.

2.2.15.10. Technical Proposal (if applicable):

- i. A detailed technical proposal (if required by the RFP) demonstrating the Bidder's approach, methodology, and understanding of the scope of work.

2.2.15.11. Other Relevant Documents:

- i. Any additional information or documentation specified in the RFP or deemed necessary to substantiate the Bidder's eligibility and compliance.

2.2.16. Anti-Bribery & Corruption (ABC) Policy

NHIT is committed to conducting all its business activities with honesty, integrity, and the highest ethical standards. We maintain a zero-tolerance approach to bribery and corruption in all forms and are dedicated to acting professionally and fairly in all our business dealings and relationships, regardless of location.

To ensure compliance, we implement and enforce robust systems and controls designed to prevent and detect bribery and corruption. We expect all employees, contractors, suppliers, and stakeholders to adhere strictly to these principles.

If you encounter or are subject to any improper demands, including bribery or corrupt practices involving NHIT employees, you are encouraged to report such incidents immediately. Reports can be made **confidentially by sending an email to whistleblow@nhit.co.in**.

NHIT ensures that all whistleblowers will be protected from retaliation and that their reports will be handled with the utmost confidentiality, in line with applicable laws and organizational policies.

2.2.17. Ethics & Integrity

The selected Agency/Firm is expected to uphold the highest standards of professional ethics, integrity, and accountability in all its dealings, operations, and interactions associated with NHIT. The Agency/Firm shall:

- a) Act in NHIT's Best Interests: Ensure that all actions, decisions, and conduct are aligned with NHIT's objectives and do not, in any manner, harm or compromise NHIT's reputation, business interests, or operational effectiveness.
- b) **Avoid Conflicts of Interest:** Proactively disclose any actual, potential, or perceived conflicts of interest that may arise during the execution of duties. The Agency/Firm must take appropriate measures to mitigate any such conflicts to ensure impartiality and transparency in all dealings.
- c) **Adhere to Laws and Regulations:** Comply with all applicable laws, rules, and regulations governing professional conduct, anti-corruption, anti-bribery, and fair business practices.

National Highways Infra Trust

 <p>NHIT National Highways Infra Trust</p>	<p>RFP for Providing Incident Management Vehicles</p>	<p>Doc No.: NHIT/FY25-26/RFP/ Incident Management-02</p>
---	--	---

- d) **Confidentiality:** Safeguard all proprietary, confidential, or sensitive information entrusted by **NHIT** and ensure that such information is not used for personal gain or disclosed to any unauthorized party.
- e) **Fair Practices:** Engage in fair business practices, avoiding any acts of dishonesty, fraud, misrepresentation, or unethical conduct.
- f) **Non-Maleficence:** Refrain from any behaviour, directly or indirectly, that may be detrimental to **NHIT's** interests, reputation, or relationships with its stakeholders, clients, or partners.

NHIT reserves the right to terminate the contract and take appropriate legal action if the Agency/Firm is found to be in violation of any aspect of this clause. Compliance with these principles is a mandatory requirement, and failure to adhere may result in disqualification, penalties, or other remedial measures as deemed necessary by **NHIT**.

2.2.18. Confidentiality Obligations under the RFP

The Agency/Firm acknowledges that **Clause 32** (Confidentiality and Non-Disclosure) and **Clause 36.3** (Confidentiality and Intellectual Property Rights) of the General Conditions of Contract (GCC) comprehensively govern the obligations of confidentiality and the treatment of intellectual property rights under the contract. In addition to those provisions, the following confidentiality obligations apply specifically to the RFP stage:

2.2.18.1. Scope of Confidentiality During the RFP Process:

All information, documents, or data shared by **NHIT** as part of the Request for Proposal (RFP) process, including but not limited to RFP documents, evaluation criteria, communication, and other proprietary information, shall be treated as confidential by the Agency/Firm.

2.2.18.2. Prohibited Actions:

- a) The Agency/Firm shall not disclose, reproduce, or use any RFP-related information for any purpose other than preparing and submitting a proposal in response to this RFP.
- b) The Agency/Firm shall not share any RFP-related information with third parties, except with employees or advisors directly involved in the proposal preparation, who must also comply with these confidentiality obligations.

2.2.18.3. Reference to GCC Obligations:

The obligations under Clause 32 and Clause 36.3 of the GCC shall apply to all information disclosed during the RFP process, including the preservation of confidentiality for intellectual property, trade secrets, and proprietary data of **NHIT**.

2.2.18.4. Exclusions from Confidentiality:

- a) Confidentiality obligations under this clause shall not apply to information that: Is publicly available at the time of disclosure or subsequently becomes publicly available through no fault of the Agency/Firm.
- b) Was lawfully in the Agency/Firm's possession before disclosure by **NHIT**.
- c) Is required to be disclosed by law, regulation, or court order, provided that the Agency/Firm gives prior written notice to **NHIT**, where permissible, and takes reasonable measures to limit the extent of such disclosure.

2.2.18.5. Survival of Obligations:

The confidentiality obligations outlined herein shall remain binding on the Agency/Firm regardless of the outcome of the RFP process and shall survive the conclusion or cancellation of this RFP for a

National Highways Infra Trust

 <p>NHIT National Highways Infra Trust</p>	<p>RFP for Providing Incident Management Vehicles</p>	<p>Doc No.: NHIT/FY25-26/RFP/ Incident Management-02</p>
---	--	---

period of at least five (5) years or as specified in Clause 32 and Clause 36.3 of the GCC, whichever is longer, **or until the information becomes public by lawful disclosure.**

2.2.18.6. Breach and Remedies:

Any breach of this confidentiality clause may result in disqualification of the Agency/Firm from the RFP process, forfeiture of the Earnest Money Deposit (EMD), or other legal or contractual remedies as deemed appropriate by **NHIT**.

2.2.18.7. Acknowledgment of Obligations:

By participating in this RFP, the Agency/Firm explicitly agrees to abide by the confidentiality obligations stated herein and acknowledges the applicability of Clause 32 and Clause 36.3 of the GCC to the RFP process.

2.2.19. Right of Removal

NHIT reserves the sole and absolute right to remove any selected Agency/Firm from the selection list at its discretion, without the obligation to provide any justification or to bear any costs, liabilities, or compensation arising from such removal. Furthermore, **NHIT** retains the right, at any stage, to replace, remove, or appoint a new Agency/Firm to fulfil ongoing or future requirements as it deems necessary to ensure the efficient execution of its projects or operations.

The exercise of this right by **NHIT** shall not be construed as a breach of any contractual obligations under the Request for Proposal (RFP) process or subsequent agreements, and no claims for damages, loss of opportunity, or compensation shall be entertained from the removed Agency/Firm.

2.2.20. Right to descope part of full

2.2.20.1. Right to Descope Due to Contractor's Failure or Other Conditions

"Notwithstanding anything contained in the Contract, **NHIT** reserves the right to partially or fully descope the Contractor's scope of work under the following circumstances:

- a. **Failure to Perform:** If the Contractor fails to meet performance standards, timelines, or quality requirements as per the Contract, despite being given reasonable opportunity to rectify the deficiencies.
- b. **Persistent Non-Compliance:** If the Contractor fails to adhere to contractual obligations, including but not limited to safety regulations, statutory compliance, or approved work methodologies.
- c. **Material Breach of Contract:** If the Contractor commits a material breach that does not warrant immediate termination but requires **NHIT** to take corrective action.
- d. **Financial or Technical Inability:** If **NHIT** determines that the Contractor is financially unstable or lacks the technical resources to execute the project efficiently.
- e. **Regulatory or Statutory Directives:** If **NHIT** is required to modify the scope due to legal, environmental, or regulatory changes affecting the project.
- f. **Project Restructuring or Budgetary Constraints:** If **NHIT** decides to restructure, reschedule, or optimize the project scope for administrative or financial reasons.

2.2.20.2. Consequences of Descope

National Highways Infra Trust

 <p>NHIT National Highways Infra Trust</p>	<p>RFP for Providing Incident Management Vehicles</p>	<p>Doc No.: NHIT/FY25-26/RFP/ Incident Management-02</p>
---	--	---

In case of partial descoping, the Contractor shall continue with the remaining scope as per the Contract, and the Contract Price shall be adjusted proportionately based on agreed unit rates.

NHIT shall have the right to re-allocate the descoped portion to another agency or execute it through its own resources without any claims or objections from the Contractor.

If the descoping is due to Contractor's failure, non-performance, or breach, NHIT reserves the right to recover additional costs incurred in getting the work executed from another party.

Performance Security shall not be released until all adjustments, claims, and recoveries (if any) are settled to NHIT's satisfaction.

2.2.20.3. Linkage with GCC Termination Clause

If the failure or non-performance leading to descoping is severe and beyond rectification, NHIT reserves the right to initiate termination as per the provisions of the Termination Clause under the GCC.

2.2.21. General Information

2.2.21.1. Vendor Profile:

The Vendor shall provide a comprehensive profile detailing the constitution, ownership structure, and core business activities of their organization. This information must be submitted as part of the Bid/Proposal to enable **NHIT** to assess the Vendor's qualifications and suitability for the assignment.

2.2.21.2. Analysis of Rates:

The Bidder is required to include a detailed Analysis of Rates as part of their Financial Proposal. The Analysis should clearly outline the basis of cost estimates, ensuring transparency and facilitating an informed evaluation by **NHIT**.

2.2.21.3. Conflict of Interest and Commitments (refer clause 2.2.4 of RFP):

The Bidder shall disclose any existing commitments, obligations, or circumstances that may either act as a constraint or result in a conflict of interest concerning the proposed assignment. Such disclosures must accompany the Bid/Proposal to ensure full transparency.

2.2.21.4. Site Visit Requirement:

It is mandatory for the Bidder to conduct a site visit prior to the submission of the Bid/Proposal. The purpose of the site visit is to enable the Bidder to assess all relevant conditions and requirements necessary for the preparation of an informed and accurate proposal. By submitting their Bid/Proposal, the Bidder acknowledges that they have accounted for all site-related considerations.

2.3. Bid Process Overview

2.3.1. Two-Envelope System (Technical & Financial)

The selection of the Successful Bidder shall follow a Two-Envelope System, comprising the **Technical Proposal** and the **Financial Proposal**, submitted in separate sealed envelopes:

(a) Technical Proposal

- i. Shall mean the part of the Bid containing the Bidder's qualifications, experience, methodology, and proposed approach for executing the Work as specified in the RFP.

National Highways Infra Trust

 <p>NHIT National Highways Infra Trust</p>	<p align="center">RFP for Providing Incident Management Vehicles</p>	<p>Doc No.: NHIT/FY25-26/RFP/ Incident Management-02</p>
--	---	---

- ii. The Technical Proposal shall be evaluated based on the criteria outlined in the RFP, including, but not limited to, experience in similar projects, equipment ownership, and personnel capabilities.
- iii. Only those Bidders whose Technical Proposals meet or exceed the prescribed minimum score shall proceed to the Financial Proposal evaluation.
- iv. Details of evaluation of technical proposal is given in the **Section 3 – Eligibility and Qualification Criteria.**

(b) Financial Proposal

- i. Shall mean the part of the Bid containing the financial offer, including the total Contract Price for executing the Work in accordance with the terms of the RFP.
- ii. The Financial Proposal shall be opened only for Bidders whose Technical Proposals are qualified, and the evaluation shall be conducted as per the methodology defined in the RFP.

(c) Evaluation Process

- i. The Authority shall open and evaluate the Technical Proposals first.
- ii. Financial Proposals of only technically qualified Bidders shall be opened.
- iii. The selection of the Successful Bidder shall be based on the evaluation methodology outlined in Clause 3 – Eligibility and Qualification Criteria, following the Quality and Cost Based Selection (QCBS) system as per NHIT's practices. The final ranking of bidders shall be determined based on their combined Technical Score (TS) and Financial Score (FS), as described in the RFP.

2.3.2. Bid Submission Procedures

2.3.2.1. General Requirements

- i. Bids shall be prepared and submitted in strict accordance with the instructions specified in the Request for Proposal (RFP).
- ii. The Bidder shall ensure that all documents and forms are complete, accurate, and duly signed by an authorized representative.
- iii. Late, incomplete, or non-compliant Bids shall not be considered and will be summarily rejected.

2.3.2.2. Submission Format

- i. The Bid shall be submitted in two separate sealed envelopes, clearly marked as follows:
Envelope 1: "Technical Proposal for [Project Name]"
Envelope 2: "Financial Proposal for [Project Name]"
- ii. Both envelopes shall be placed in an outer sealed envelope marked as:
"Bid Submission for [Project Name] – Do Not Open Before [Bid Opening Date]"

2.3.2.3. Mode of Submission

- i. Bids must be submitted either in person or via registered post/courier to the address specified in the RFP, ensuring that they are received before the Bid Due Date and time.

National Highways Infra Trust

 <p>NHIT National Highways Infra Trust</p>	<p>RFP for Providing Incident Management Vehicles</p>	<p>Doc No.: NHIT/FY25-26/RFP/ Incident Management-02</p>
---	--	---

- ii. The Employer/Authority shall not be responsible for any delays in submission due to postal, courier services, or other external factors. The Bidder is solely responsible for ensuring timely submission.
- iii. If electronic submission is permitted as per Clause 2.3.2.8, Bidders may also submit their Bids through the designated online platform, subject to compliance with the RFP requirements.

2.3.2.4. Bid Validity

- i. The Bid shall remain valid for a period of **[120 days]** from the Bid Due Date, unless extended by mutual written agreement between the Employer and the Bidder.
- ii. The Employer may request an extension of Bid validity if required during the evaluation period. The Bidder shall respond promptly to such requests.

2.3.2.5. Modification or Withdrawal of Bids

- i. The Bidder may modify or withdraw its Bid before the Bid Due Date by submitting a written notice to the Employer/Authority.
- ii. No Bid shall be modified or withdrawn after the Bid Due Date. Any attempt to do so will result in the disqualification of the Bidder.

2.3.2.6. Bid Opening

- i. The Technical Proposals shall be opened on the date and time specified in the RFP, in the presence of Bidder representatives who choose to attend.
- ii. The Financial Proposals shall only be opened for those Bidders who are found technically qualified. The date and time for the opening of Financial Proposals shall be communicated separately to the qualified Bidders.

2.3.2.7. Late Bids

Any Bid received after the Bid Due Date and time, as stipulated in the RFP, shall be considered late and shall not be evaluated. Such Bids will be returned unopened to the Bidder, unless the delay was caused by force majeure or other exceptional circumstances, as determined by the Employer.

2.3.2.8. Electronic Submission (if applicable)

- i. If electronic submission of Bids is permitted, the Bidder shall submit the Bid via the designated online platform, ensuring that the required digital signatures are affixed.
- ii. The Bidder must ensure that the submission complies with the technical specifications and format requirements as outlined in the RFP.
- iii. In case both electronic and physical submissions are permitted, the physically submitted Bid shall prevail in the event of any discrepancies.
- iv. If the Contract Data Sheet (CDS) mandates only electronic submission, then physical submission will not be required.

2.3.2.9. Bid Clarifications

National Highways Infra Trust

 <p>NHIT National Highways Infra Trust</p>	RFP for Providing Incident Management Vehicles	Doc No.: NHIT/FY25-26/RFP/ Incident Management-02
---	---	--

- i. The Employer reserves the right to request clarifications or additional information from the Bidders during the evaluation process.
- ii. All clarifications shall be requested in writing, and Bidders shall respond in a timely manner.
- iii. Any response or clarification provided by the Bidder will be considered part of the Bid and may be evaluated accordingly.

2.3.2.10. Rejection of Non-Compliant Bids

- i. Any Bid that does not comply with the Bid submission procedures as outlined in this Sub-**Clause 2.3** shall be rejected by the Employer.
- ii. Bidders shall ensure that their Bids are fully compliant with the submission requirements, including format, documents, and signatures, to avoid rejection.

2.4. Bid Security Details

The Bidder shall furnish Bid Security (Earnest Money Deposit, or "EMD") as a guarantee to ensure the Bidder's bona fide intention to participate in the bidding process and to safeguard the Employer from the risk of Bidder's withdrawal or failure to comply with the terms of the RFP or any other conditions specified in the Contract. The EMD shall be submitted as per the details set forth below.

2.4.1. Earnest Money Deposit (EMD)

The Earnest Money Deposit (EMD) amount shall be either a fixed sum or a percentage of the estimated project cost, as specified hereinbelow. The EMD must be submitted by the Bidder in the prescribed form and shall be in accordance with the instructions provided in this **Clause**. Failure to submit the EMD in the specified format shall result in the disqualification of the Bid.

- i. **Amount/Percentage:** **[As specified in Contract Data Sheet]**
- ii. **Mode of Submission:** The EMD shall be submitted in the form of a Demand Draft (DD), Banker's Cheque, or a Bank Guarantee issued by a Scheduled Commercial Bank in India, payable in favour of [Employer Name]. The validity of the EMD shall be for a period of **[90] days**.
- iii. **Retention & Refund:**
 - a) The EMD of the successful Bidder shall be retained until the execution of the Contract Agreement or the submission of the Performance Security, whichever occurs earlier.
 - b) The EMD of unsuccessful Bidders will be refunded promptly upon finalization of the contract award process.
 - c) No interest shall be payable on the EMD amount under any circumstances.
- iv. **Forfeiture of EMD:**
 - a) The EMD may be forfeited under the following conditions:
 - b) If the Bidder withdraws or modifies its bid during the bid validity period.
 - c) If the Bidder refuses to accept the Letter of Award (LOA) after being selected as the successful Bidder.
 - d) If the successful Bidder fails to sign the Contract Agreement within the stipulated time.
 - e) If the Bidder fails to furnish the required Performance Security within the prescribed period.
 - f) If any fraudulent or misleading information is found in the bid documents.

2.4.2. Bank Guarantee Template for Bid Security

National Highways Infra Trust

 <p>NHIT National Highways Infra Trust</p>	<p>RFP for Providing Incident Management Vehicles</p>	<p>Doc No.: NHIT/FY25-26/RFP/ Incident Management-02</p>
---	--	---

A Bank Guarantee, in lieu of the Earnest Money Deposit (EMD), may be submitted as an alternative mode of Bid Security. In such cases, the Bank Guarantee must comply with the prescribed format and requirements specified in **Annexure [B1]** of this RFP.

The Bank Guarantee shall:

- Be issued by a Scheduled Commercial Bank in India.
- Be irrevocable and unconditional.
- Be valid for a period of **[180] days** from the final date for submission of the bid (including any extension period).
- Contain a clear and specific statement of the guarantee amount and a reference to the **Invocation Clause**, as detailed in the Bank Guarantee template provided in the Annexure.

A template of the Bank Guarantee format is provided in **Annexure [B1]**, which must be strictly adhered to while submitting the Bank Guarantee.

2.5. Clarifications and Addendum

2.5.1. Pre-Bid Queries and Responses

- (a) **Submission of Queries:** Bidders may submit queries or seek clarifications regarding the bid documents within the timeline specified in the Key Dates section of this RFP. All queries shall be submitted in writing via email or through the official communication channel specified in Section 1.4.
- (b) **Format for Queries:** Queries must be submitted in the prescribed format, mentioning the relevant section, Clause No., or provision of the RFP for which clarification is sought.
- (c) **Response to Queries:** The Client shall provide responses to all queries received within the stipulated timeline. These responses shall be made available to all bidders via email or uploaded on the official tender portal.
- (d) **No Individual Clarifications:** No bidder shall communicate directly with any Authority representative for clarification outside the specified channels.

2.5.2. Issuance of Corrigendum/Addendum

- (a) **Client's Right to Amend:** The Client reserves the right to modify, amend, or issue Corrigendum to the RFP documents before the bid submission deadline.
- (b) **Communication of Changes:** All Corrigendum/Addendum shall be communicated via the official tender portal. If deemed necessary, the Authority may also notify bidders via the email address provided during registration. No other form of communication shall be deemed valid.
- (c) **Binding Nature:** All Corrigendum/Addendum issued by the Authority shall be considered an integral part of the RFP documents and binding upon all bidders.
- (d) **Deadline Extensions:** If necessary, the Authority may, at its discretion, extend the bid submission deadline to provide adequate time for bidders to incorporate changes communicated through Corrigendum/Addendum.
- (e) **Responsibility of Bidders:** All Corrigendum/Addendum uploaded on the official tender portal shall be deemed to have been duly communicated to all bidders. It shall be the sole responsibility of bidders to regularly check the official portal for updates. If a corrigendum/addendum is also communicated via email, bidders shall acknowledge receipt within the specified timeframe. Failure to acknowledge shall not absolve the bidder from complying with the issued modifications.

National Highways Infra Trust

 <p>NHIT National Highways Infra Trust</p>	<p>RFP for Providing Incident Management Vehicles</p>	<p>Doc No.: NHIT/FY25-26/RFP/ Incident Management-02</p>
---	--	---

2.6. Bid Validity Period

The Bid shall remain valid for a period of **120 days** from the **last date of submission of the Financial Bid**. The Bidder agrees to keep the offer open and unaltered for acceptance by the Employer during this period, without modification or withdrawal.

The following terms and conditions shall apply with respect to the Bid Validity Period:

- **Commencement of Validity:**

The 120-day validity period shall commence from the last date of submission of the Financial Bid, and shall expire on the 120th day thereafter, unless extended by mutual consent of the Employer and the Bidder.

- **Extension of Validity:**

If, in the opinion of the Employer, the bid evaluation process cannot be concluded within the validity period, the Employer may request an extension of the validity period. The Bidder shall, at the sole discretion of the Employer, extend the validity of the Bid for the requested period, on the same terms and conditions, including the pricing. Such an extension shall be formalized through a written agreement between the Employer and the Bidder.

- **Bidder's Obligation During Bid Validity:**

During the Bid Validity Period, the Bidder shall not revoke or withdraw their Bid. The Bidder shall keep their Bid open for acceptance without any unilateral alteration to the terms, conditions, or prices specified in their submission.

However, in the following circumstances, a Bidder may be allowed to revise and resubmit their Bid:

- a. **Changes or Addendums by NHIT:** If NHIT issues any corrigendum, addendum, or modification to the RFP documents after Bid submission, Bidders shall have the right to revise and resubmit their Bids in accordance with the revised terms, within the prescribed timeframe.
- b. **Correction of Genuine Errors Prior to Bid Opening:** A Bidder (only once) may request a revision of their submitted Bid before the scheduled bid opening date if they provide a written request along with a detailed justification and analysis of the error, demonstrating that the revision is necessary due to an inadvertent mistake and not due to any malpractice or unfair advantage.
- c. **Ensuring Fair Competition:** Any request for Bid revision shall be subject to NHIT's approval, ensuring that no unfair advantage is given to any Bidder. NHIT reserves the right to reject any revision request if it finds that the change could compromise the integrity of the bidding process or create an imbalance among competing Bidders.

Once the Bids are opened, no revisions, modifications, or withdrawals shall be permitted under any circumstances.

- **Failure to Extend Validity:**

If the Bidder refuses or fails to extend the Bid Validity Period when requested by the Employer, the Bid shall be considered non-responsive, and the Bidder shall be disqualified from further consideration.

- **Force Majeure:**

National Highways Infra Trust

	RFP for Providing Incident Management Vehicles	Doc No.: NHIT/FY25-26/RFP/ Incident Management-02
---	---	--

In the event of Force Majeure or other circumstances beyond the control of the Employer, the Bid Validity Period may be extended, subject to mutual agreement between the Employer and the Bidder.

2.7. Evaluation Process

The evaluation of Bids shall be conducted in accordance with the eligibility, technical, and financial criteria detailed in **Clause 3 (Eligibility and Qualification Criteria) of this RFP**. The process shall be fair, transparent, and objective, based on the information provided by the Bidders.

2.7.1. Technical Bid Evaluation (for details refer clause no. 3.4 – Technical evaluation Criteria)

The Technical Bid shall be evaluated based on key parameters, including but not limited to **bidder's experience, technical approach, methodology, key personnel, equipment, financial capacity, and past performance**. For detailed evaluation criteria and scoring methodology, refer to **Clause 3.4 – Technical Evaluation Criteria**.

The **Technical Bid** will be evaluated on a **pass/fail** basis. Any Bid that does not meet the minimum technical requirements specified in the RFP will be deemed non-responsive and disqualified from further evaluation.

2.7.2. Financial Bid Evaluation

The Financial Bids of only the **technically qualified Bidders** shall be opened and evaluated to determine the **most advantageous offer**, considering the bid price, conformance to payment terms, and completeness of the financial proposal. The Financial Bid evaluation shall be conducted in accordance with the criteria specified in **Clause 3.6 – Financial Criteria**.

The **Financial Bid** will be scored based on the lowest responsive bid, considering both the total cost and the value offered in terms of quality, safety, and time. In the event of a tie, the Employer may decide to engage in negotiations or apply additional criteria to determine the final award.

National Highways Infra Trust

 <p>NHIT National Highways Infra Trust</p>	<p>RFP for Providing Incident Management Vehicles</p>	<p>Doc No.: NHIT/FY25-26/RFP/ Incident Management-02</p>
---	--	---

3. Eligibility and Qualification Criteria

This section outlines the eligibility and qualification criteria for bidders to ensure that only qualified and capable entities participate in the bidding process. The bidder must meet the specified technical, financial, and legal requirements to be considered eligible for the award of the contract.

The detailed technical and financial eligibility requirements specific to this project are provided in the Contract Data Sheet (CDS). Bidders are advised to **carefully refer to the Contract Data Sheet and all associated annexures** for project-specific qualification parameters, thresholds, formats, and documentary requirements before preparing their bid.

3.1. General Eligibility Criteria

3.1.1. To be eligible for bidding, the Bidder must fulfil the following general eligibility requirements:

3.1.2. Legally Established Entity:

The Bidder must be a legally registered entity in India or an eligible international entity, including a consortium, joint venture (JV) if allowed for this RFP (refer CDS clause 5.3), or partnership. Valid proof such as a certificate of incorporation, partnership deed, or joint venture agreement must be provided.

3.1.3. Notification of Changes in Firm's Name, Structure, or Merger

At any stage during the RFP process or after contract award, the Bidder must immediately notify NHIT in writing in the event of:

- i. A change in the name of the firm or its legal identity.
- ii. Any restructuring, reorganization, or change in the ownership or controlling interest of the firm.
- iii. Merger, acquisition, or amalgamation with any other entity, whether domestic or international.

NHIT reserves the right to assess the impact of such changes on the Bidder's eligibility and performance obligations. If NHIT determines that such changes adversely affect the Bidder's qualifications, financial stability, or conflict-of-interest status, NHIT may:

- a. Disqualify the Bidder from the RFP process.
- b. Terminate the contract without liability to NHIT.
- c. Invoke performance security and recover damages for any financial or reputational impact.

Failure to disclose any such change shall be treated as a material breach of contract and may result in immediate disqualification or contract termination.

3.1.4. Experience & Capability: The Bidder must demonstrate experience in executing infrastructure projects of a similar nature and scale. The total value of work completed should reflect the Bidder's financial and technical ability to handle the project. Supporting documents such as completion certificates, project references, and contract details must be provided.

3.1.5. Statutory Compliance: The Bidder must have valid GST registration, PAN, and other applicable statutory registrations. Documentary proof must be submitted.

3.1.6. No Blacklisting: The Bidder should not have been blacklisted or debarred by **Central Public Sector Undertaking (CPSU), State Public Sector Undertaking (SPSU), government companies, government organizations, or regulatory authorities, NHA, NHIT and NHIT's subsidiaries.** A self-declaration certificate confirming the non-blacklisting status must be provided.

National Highways Infra Trust

 <p>NHIT National Highways Infra Trust</p>	<p>RFP for Providing Incident Management Vehicles</p>	<p>Doc No.: NHIT/FY25-26/RFP/ Incident Management-02</p>
---	--	---

- 3.1.7. Financial Soundness:** The Bidder must meet the minimum financial criteria specified under Clause 3.4 (Financial Criteria) to demonstrate its ability to execute the contract successfully.
- 3.1.8.** As part of the eligibility assessment, bidders must comply with the requirements specified in **Clause 2.2.7.3 (Verification of Commitments)**. Failure to submit the required statement of commitments, or submission of an incomplete or unverified statement, may result in disqualification of the bid.
- 3.1.9.** Failure to meet these general eligibility criteria shall result in automatic disqualification from the bidding process.

3.2. Technical Criteria (Similar Project Experience) refer cl. 5.2 of CDS

The Bidder must demonstrate relevant experience in executing projects of similar nature, scope, and complexity. The technical qualifications shall be based on the Bidder's proven capability in handling projects that are comparable in scale and scope to the one proposed herein. The technical criteria for eligibility shall be as follows:

3.2.1. Similar Project Experience:

3.2.1.1. The Bidder should have successfully completed, as the lead contractor or a joint venture partner, at least [3] projects of a similar nature, involving relevant projects as specified in the Scope of Work.

3.2.1.2. These projects should have been completed within the last [5] years.

3.2.2. Nature of Work:

- i. The projects should have involved activities such as Bridge Rehabilitation and Repair of similar scale, complexity, and technology as outlined in this RFP.

3.2.3. Value of Works Executed:

- i. The Bidder must have executed works with a minimum total contract value of **[as specified in Contract Data Sheet]**, either individually or collectively across similar projects.
- ii. The value of such works should have been completed in the past **[5] years**.

3.2.4. Supporting Documentation: The Bidder shall submit the following documents to substantiate their technical experience:

- i. Completion certificates from the Employer or the client for each project undertaken.
- ii. Detailed description of the project scope, including the Bidder's role and responsibilities.
- iii. Contract value and duration of the project.

Failure to provide the required documentation or evidence of similar project experience may result in the disqualification of the Bidder.

3.3. Specific Eligibility Criteria – refer Cl. 5.2 of CDS

Bidders must meet the following project-specific eligibility requirements based on the type of work they are bidding for:

3.3.1. Road Maintenance Works

- i. The Bidder must have successfully completed at least **three (3)** road maintenance projects on national or state highways within the **past five (5) years**.

National Highways Infra Trust

	RFP for Providing Incident Management Vehicles	Doc No.: NHIT/FY25-26/RFP/ Incident Management-02
---	---	--

- ii. The total value of these completed projects must be at least **for the amount as specified in Contract Data Sheet**, demonstrating financial capacity.
- iii. The scope of work should include periodic maintenance, overlays, and routine upkeep of road infrastructure.
- iv. The Bidder must own or have access to essential equipment such as milling machines, pavers, compactors, and hot-mix plants.
- v. Supporting documents: Project completion certificates, scope of work, and proof of equipment ownership/access.

3.3.2. Toll Management Works

- i. The Bidder must have a **minimum of two (2) years** of experience in toll plaza operation and management.
- ii. The total value of toll management contracts handled should reflect the Bidder's ability to manage toll revenue and operations.
- iii. Experience should include operation of electronic toll collection systems, manual toll collection, and revenue reconciliation.
- iv. Supporting documents: Performance certificates, reference letters, and toll operations reports.

3.3.3. Civil Works

- i. The Bidder must have completed civil engineering projects related to highway construction, bridge repairs, or related infrastructure.
- ii. The scope should include road construction, bituminous macadam, reinforced concrete structures, grading, and drainage systems.
- iii. The total value of such projects must be at least **[as specified in Contract Data Sheet]** amount within the **last five [5] years**.
- iv. The Bidder must own or have access to batching plants, transit mixers, bitumen sprayers, and crushers.
- v. Supporting documents: Project details, completion certificates, proof of equipment ownership/access.

3.3.4. Electrical Works

- i. The Bidder must have experience in installation, operation, and maintenance of electrical systems for highways or toll plazas.
- ii. Experience should cover highway lighting, traffic signals, and high-mast lighting installations.
- iii. The total value of executed electrical works should be at least [as specified in Contract Data Sheet] amount.
- iv. The Bidder must own or have access to cranes, hydraulic platforms, and certified testing devices.
- v. Supporting documents: Project completion certificates, safety compliance reports, and equipment access proof.

3.4. Technical Evaluation Criteria

The technical evaluation of the bids will be carried out based on the criteria outlined in the table below. Each bidder will be evaluated on the basis of the following parameters, and the maximum marks that can be awarded under each criterion are specified.

National Highways Infra Trust

 National Highways Infra Trust	RFP for Providing Incident Management Vehicles	Doc No.: NHIT/FY25-26/RFP/ Incident Management-02
--	---	--

Minimum Qualifying Score – The bidder must achieve a minimum of **60 marks (out of 100)** in the technical evaluation to qualify for the financial bid opening. Bidders who score below the minimum qualifying score will not be considered further in the evaluation process.

3.4.1. Technical Evaluation Matrix

Sr. No.	Evaluation criteria & scoring guidance	Maximum Points
1	Minimum 3 Years' Experience in Similar field:	25
	03 Years to 5 Years: 15 Marks	
	> 5 Years to 10 Years: 20 Marks	
	> 10 Years: 25 Marks	
2	Cumulative Turnover for the Last Three years for Similar work:	25
	2 Crore to 5 Crore: 15 Marks	
	> 5 Crore to 10 Crore: 20 Marks	
	> 10 Crore: 25 Marks	
3	Number of Client base with Bidder in past 5 years	30
	03 Clients to 05 Clients: 20 Marks	
	06 Clients to 08 Clients: 25 Marks	
	> 9 Clients: 30 Marks	
	Documents Required: WOs/Completion Certificate copies issued by client.	
4	Number of Incident Management vehicles owned by the Bidder	20
	05 to 10 Vehicles – 10 Marks	
	11 to 15 Vehicles – 15 Marks	
	16 or more Vehicles – 20 Marks	

Note: Bidders who have submitted bids against Tender No. NHIT/FY25-26/RFP/Incident Management, uploaded on the NHIT website on 27th February 2026, are not required to submit the Technical Proposal again. Such bidders may submit only the Financial Proposal.

Bidders who were found technically qualified in the above-mentioned tender shall be considered pre-qualified bidders for this RFP as well.

3.5. Documents to be Furnished

Bidders must provide the following documents to support their technical proposals. Failure to provide the required documents will result in disqualification:

3.5.1. General Eligibility Documents:

- Registration certificate of the bidder entity (including consortium or joint venture, if applicable).
- GST certificate.
- PAN card.
- A self-declaration stating that the bidder is not blacklisted by any government authority in India.

3.5.2. Technical Proposal Documents:

- A detailed technical approach and methodology document outlining the steps and processes to be followed.

National Highways Infra Trust

 <p>NHIT National Highways Infra Trust</p>	RFP for Providing Incident Management Vehicles	Doc No.: NHIT/FY25-26/RFP/ Incident Management-02
---	---	--

- b) CVs and qualifications of key personnel, demonstrating their expertise in managing similar projects.
- c) List and description of the equipment and technology that will be used during the project.
- d) Equipment ownership or lease agreements.

3.5.3. Financial Documents:

- a) Audited financial statements for the last three financial years.
- b) Bank statements showing financial capacity.
- c) Proof of tax compliance.

3.5.4. Experience Documents:

- a) Completion certificates for at least three projects of a similar nature and scale, along with client references.
- b) Details of completed projects (including scope, value, and timelines) to substantiate the bidder's experience.

3.5.5. Safety and Environmental Management Documents:

- a) A safety management plan.
- b) Environmental compliance certificates or reports from previous projects.
- c) Details of any relevant certifications related to quality or safety management systems (e.g., ISO).

3.5.6. Previous Performance on NHAI/Highway Projects:

- a) Reference letters or performance certificates from clients for projects similar in scope or value.
- b) Evidence of the bidder's past performance on NHAI or highway projects.

3.5.7. Evaluation Methodology

The evaluation will be conducted in the following manner:

- i. **Step 1: Preliminary Scrutiny** – Checking completeness of documents.
- ii. **Step 2: Technical Evaluation** – Assessing bidder experience, project execution capability, equipment, and personnel based on the above matrix and document submitted.
Bidders must secure a minimum of 70 marks in the technical evaluation to move to the next stage.
- iii. **Step 3: Financial Qualification** – Evaluating financial soundness based on audited statements and turnover. Financial proposals of only those bidders who have qualified in the technical evaluation will be opened and evaluated.
- iv. **Step 4: Final Scoring & Selection** – Assigning weighted scores and finalizing technically qualified bidders.

The Client reserves the right to reject any technical proposal that does not meet the minimum requirements or fails to submit the requisite documents.

3.6. Financial Criteria (Net Worth, Turnover, etc.)

The Bidder must satisfy the **financial eligibility criteria** to ensure their financial stability and capacity to undertake and complete the project. Additionally, the evaluation of the **Financial Bids** shall consider compliance with cost structure, payment terms, and bid completeness. The criteria for financial evaluation are as follows:

3.6.1. Financial Eligibility Criteria:

The Bidder must meet the following financial requirements to qualify for bid evaluation:

National Highways Infra Trust

 <p>NHIT National Highways Infra Trust</p>	RFP for Providing Incident Management Vehicles	Doc No.: NHIT/FY25-26/RFP/ Incident Management-02
---	---	---

- i. **Net Worth:** The Bidder must have a minimum net worth of **[as specified in Contract Data Sheet]** as of the most recent financial year. The net worth should be certified by a Chartered Accountant or an equivalent financial expert, and the certificate must be included with the bid.
- ii. **Annual Turnover:** The Bidder must have an average annual turnover of at least **[as specified in Contract Data sheet]** over the last **[3] financial years**. This turnover must be derived from core business activities related to infrastructure development and project management.
- iii. **Solvency and Credit Rating:** The Bidder should provide a letter from a recognized financial institution stating their current solvency and creditworthiness, which shall demonstrate their ability to mobilize funds for the project.
- iv. **Financial Documents:** The Bidder must submit the following:
 - a) Audited financial statements for the last **[3] years**, including profit and loss statements, balance sheets, and cash flow statements.
 - b) A certificate from a Chartered Accountant stating the average annual turnover and the net worth for the relevant period.
 - c) Any other documents that demonstrate the Bidder's financial strength, including letters of credit, bank statements, or solvency certificates, if applicable. Failure to meet the financial criteria or provide the required supporting documents may lead to the rejection of the bid.

3.6.2. Financial Bid Evaluation:

The Financial Bids of only the **technically qualified Bidders** shall be opened and evaluated to determine the **most advantageous offer**, considering the following:

- i. **Bid Price:** The overall price quoted by the Bidder shall be evaluated to ensure compliance with the cost structure and pricing details specified in the RFP. The Employer reserves the right to **reject any bid** if the pricing is deemed **excessively high or unreasonably low**.
- ii. **Conformance to Payment Terms:** The financial proposal must align with the **payment schedule and terms** defined in the RFP.
- iii. **Completeness of Financial Proposal:** The financial bid shall be assessed for **completeness**, ensuring that **all required items, works, and deliverables** under the Contract are properly priced.

The Financial Bid shall be evaluated based on the **Lowest Responsive Bid**, considering both the total cost and the value offered in terms of quality, safety, and timely execution. In case of a **tie**, the Employer may opt for **negotiations** or apply additional criteria to determine the final award.

3.7. Legal and Regulatory Requirements

The Bidder must comply with all applicable laws, regulations, and statutory obligations under Indian law, as well as the regulatory requirements set by the Employer, including but not limited to the following:

- 3.7.1. **Incorporation and Legal Status:** The Bidder must be a legally constituted entity under Indian law, registered as a corporation, partnership, or joint venture. The Bidder must provide a copy of the certificate of incorporation, articles of association, and other relevant documents proving their legal status.
- 3.7.2. **Tax Compliance:** The Bidder must submit a valid Goods and Services Tax (GST) registration certificate, along with evidence of good standing in compliance with all applicable tax obligations. In addition, the Bidder must have filed tax returns for the last **[5] years**.
- 3.7.3. **No Litigation or Legal Disputes:** The Bidder must declare that they are not involved in any litigation or legal disputes that may affect their ability to perform the contract. The Bidder must submit a

National Highways Infra Trust

 <p>NHIT National Highways Infra Trust</p>	<p>RFP for Providing Incident Management Vehicles</p>	<p>Doc No.: NHIT/FY25-26/RFP/ Incident Management-02</p>
---	--	---

self-certification regarding the absence of any ongoing or past legal disputes, particularly those that may affect the project's execution.

3.7.4. Debarment or Blacklisting: The Bidder must not be debarred, blacklisted, or otherwise disqualified from bidding on projects by NHIT and its subsidiaries, any government agency, department, or public authority. A declaration confirming this must be provided by the Bidder.

3.7.5. Other Regulatory Compliance: The Bidder must comply with all relevant local, state, and central government laws and regulations, including but not limited to labor laws, environmental regulations, and safety standards. The Bidder must submit necessary documentation to demonstrate compliance with these regulatory requirements.

Failure to meet these legal and regulatory requirements, or to provide the necessary documentation, may result in the rejection of the Bidder's proposal.

3.8. Disqualification Criteria

NHIT reserves the right to disqualify any bidder or Respondent, at its sole discretion, at any stage during the evaluation of proposals, in the event that the Respondent:

3.8.1. Late Submission:

Submits the proposal documents after the specified bid due date and time, regardless of the reason for delay.

3.8.2. Misrepresentation or False Information:

Makes any misleading or false representations, or provides false, inaccurate, or incomplete information in the forms, statements, or supporting documents submitted to demonstrate eligibility or compliance with the requirements.

3.8.3. Failure to Provide Clarifications:

Fails to provide relevant clarifications or additional information, as requested by **NHIT**, within the stipulated time frame.

3.8.4. Ineligibility Due to Debarment or Blacklisting:

The Respondent, or any of its directors, shall be deemed ineligible if they have been declared ineligible or debarred by any Central Public Sector Undertaking (CPSU), State Public Sector Undertaking (SPSU), government companies, government organizations, regulatory authorities, NHA, NHIT, or NHIT's subsidiaries for involvement in corrupt practices, fraudulent conduct, or any other criminal activity. Additionally, any bidder found to be blacklisted by such entities will be disqualified from participation in this RFP process.

3.8.5. Mandatory Disclosure & Consequences of Non-Disclosure

The Bidder shall submit a self-declaration affidavit stating that neither the Bidder nor any of its directors or key personnel have been debarred or blacklisted by any entity mentioned in Clause 3.8.1.4. This affidavit shall be provided along with the bid submission.

In the event that NHIT discovers, at any stage of the bidding process or contract execution, that the Bidder was blacklisted or debarred at the time of submission and failed to disclose such information:

- i. The bid shall be summarily rejected, or the contract shall be terminated immediately.
- ii. NHIT shall forfeit any performance security or earnest money deposit (EMD) submitted by the Bidder.

National Highways Infra Trust

 <p>NHIT National Highways Infra Trust</p>	<p>RFP for Providing Incident Management Vehicles</p>	<p>Doc No.: NHIT/FY25-26/RFP/ Incident Management-02</p>
---	--	---

- iii. NHIT reserves the right to recover damages for any financial, reputational, or operational loss incurred due to the misrepresentation.
- iv. The Bidder shall be permanently blacklisted from future NHIT projects.
NHIT may also conduct background verification checks at its sole discretion to confirm the authenticity of the Bidder's disclosures. Any false statement, concealment, or misrepresentation shall be treated as fraudulent practice, and NHIT shall be entitled to take appropriate legal action.

3.8.6. Joint Venture (JV) Eligibility: Bidders submitting their proposal as a Joint Venture (JV) must strictly adhere to the eligibility criteria as specified in this RFP. Any JV submitted in a form other than that prescribed in this document will be deemed non-compliant. Such JV bidders shall be considered ineligible, and their bids will be summarily rejected without further consideration.

3.8.7. Disputes with NHIT Entities: Bidders who have an unresolved dispute with any NHIT entities or have previously defaulted in the provision of services or execution of works for NHIT shall be deemed ineligible to participate in this RFP. The Bidder's past performance with NHIT Entities will be thoroughly reviewed, and any history of defaults or contractual disputes may result in disqualification from the bidding process.

3.8.8. Non-Workable & Unjustified Bids

A Bidder shall be liable for disqualification from the RFP process or contract termination if the bid submitted is deemed non-workable, irrationally low, or lacking proper justification. The following conditions shall apply:

- i. **Unrealistic Pricing:** If NHIT determines that the Bidder has submitted an abnormally low bid that appears non-workable, with the potential to compromise project quality, financial viability, or timely completion.
- ii. **Failure to Justify Quoted Rates:** If the Bidder fails to submit a detailed rate analysis, cost breakdown, or backup documentation demonstrating the viability of the quoted rates within the stipulated time upon NHIT's request.
- iii. **Inability to Provide Work Methodology:** If the Bidder is unable to furnish a credible work methodology, resource allocation plan, or execution strategy ensuring compliance with project deliverables as outlined in the scope document.
- iv. **Malafide Intentions or Price Disruption:** If it is reasonably established that the Bidder has deliberately submitted an abnormally low bid with mala-fide intent to manipulate prices, disrupt fair competition, or create a non-competitive market scenario.
- v. **Non-Compliance with Deliverables:** If the quoted rates, work methodology, or resource commitments fail to meet the scope and quality requirements, thereby affecting project execution, NHIT reserves the right to disqualify the Bidder at any stage of the bidding or execution process.

NHIT, at its sole discretion, may seek additional clarifications, rate justifications, or performance commitments from the Bidder. If the Bidder fails to provide satisfactory explanations or evidence of feasibility, NHIT reserves the right to:

- a) Disqualify the Bidder from the tender process.
- b) Terminate the contract if already awarded.
- c) Invoke performance security and recover damages for project risks caused due to the non-workable bid.

National Highways Infra Trust

 <p>NHIT National Highways Infra Trust</p>	<p>RFP for Providing Incident Management Vehicles</p>	<p>Doc No.: NHIT/FY25-26/RFP/ Incident Management-02</p>
---	--	---

- d) Blacklisting the Bidder from future NHIT projects.

NHIT's decision in assessing the workability of the bid shall be final and binding, and no claims or disputes regarding disqualification under this clause shall be entertained.

General Provisions:

- **NHIT** reserves the right to evaluate the responsiveness, eligibility, and qualification of Bidders based on the information provided in the proposal and any clarifications sought by **NHIT**.

The decision to disqualify a Bidder under the above criteria shall be final and binding, and no claims for compensation or reconsideration shall be entertained.

3.8.9. Disqualification for Duplicate Bids or Collusion

A bidder shall be disqualified from the RFP process, and their bid shall be summarily rejected, if at any stage NHIT determines that:

- Duplicate or Multiple Bids** – The Bidder has submitted more than one bid for the same project, either directly or indirectly, through different entities, Joint Ventures, Consortiums, or affiliated companies, in violation of Clause 2.2.1.5.
- Collusion with NHIT Employees** – The Bidder is found to have engaged in direct or indirect collusion with any NHIT employee, representative, or consultant to gain an unfair advantage in the bidding process.

iii. Prohibition on Collusion Among Bidders

"Collusion Among Bidders: If NHIT determines that two or more Bidders have engaged in any form of collusion, cartelization, price-fixing, bid rotation, or any other anti-competitive practice to manipulate the bidding process or restrict fair competition, all such Bidders shall be immediately disqualified from the RFP process.

In addition, NHIT reserves the right to:

- a. Forfeit the Earnest Money Deposit (EMD) or Performance Security of the colluding Bidders.
- b. Blacklist the involved Bidders from future NHIT tenders for a specified period.
- c. Report the collusion to relevant regulatory authorities for further legal action.

The determination of collusion shall be at NHIT's sole discretion and may be based on direct evidence, circumstantial findings, or independent investigation. Any such decision shall be final and binding, with no claims entertained from the affected Bidders.

- iv. **Fraudulent or Manipulative Practices** – The Bidder has attempted to influence the RFP process by unethical means, including bribery, coercion, or unauthorized communication with NHIT officials regarding bid evaluation.

National Highways Infra Trust

 <p>NHIT National Highways Infra Trust</p>	<p align="center">RFP for Providing Incident Management Vehicles</p>	<p>Doc No.: NHIT/FY25-26/RFP/ Incident Management-02</p>
--	---	---

If any of the above violations are detected at any stage of the RFP process or contract execution, NHIT reserves the right to:

- a) Reject the bid immediately without further evaluation.
- b) Terminate the contract if already awarded.
- c) Forfeit the Earnest Money Deposit (EMD) or Performance Security.
- d) Blacklist the Bidder from participating in future NHIT projects.
- e) Initiate legal proceedings as per applicable laws.

NHIT shall not be liable for any claims, damages, or expenses incurred by the Bidder due to disqualification under this clause.

National Highways Infra Trust

 <p>NHIT National Highways Infra Trust</p>	<p>RFP for Providing Incident Management Vehicles</p>	<p>Doc No.: NHIT/FY25-26/RFP/ Incident Management-02</p>
---	--	---

4. Project Information

As provided in the Contract Data Sheet

4.1. Scope of Work

The Scope of Work under this Request for Proposal (RFP) is outlined in detail in **Annexure [C2]**, which constitutes an integral and binding part of this document. The works to be undertaken by the successful bidder shall align with the objectives of this RFP and encompass activities associated with the maintenance, management, procurement, or consultancy of road infrastructure and allied systems.

The successful bidder shall assume full responsibility for the planning, execution, and completion of the assigned works in strict accordance with the terms and conditions set forth in the contract agreement. This includes unwavering adherence to all applicable technical standards, specifications, and industry best practices, ensuring compliance with quality, safety, environmental, and statutory requirements at all stages of the project.

All works shall be executed with the highest standards of professionalism, diligence, and efficiency, ensuring the timely delivery of services while minimizing disruptions to ongoing operations. The bidder shall deploy appropriate and adequate resources, including skilled personnel, equipment, and materials, to achieve the objectives outlined in the detailed Scope of Work.

The specific obligations, deliverables, timelines, and performance metrics are comprehensively detailed in **Annexure [C2]**, which forms an integral and binding part of this RFP. Bidders are required to thoroughly review, comprehend, and unconditionally acknowledge the provisions set forth in **Annexure [C2]** as a mandatory prerequisite for submitting their proposals. Non-compliance with this requirement may result in the rejection of the proposal.

Furthermore, the bidder shall proactively address any challenges or deviations encountered during the execution of the works, ensuring prompt communication with the contracting authority and effective resolution of issues in alignment with the contract terms.

The Bidder is required to carefully review the entire Scope of Work to ensure they understand all the activities and responsibilities entailed in the project execution.

4.2. Site Details and Location Maps

This section provides essential information about the project site, including site conditions, access, and any specific challenges that may affect the execution of the works. The Bidder must thoroughly review these details to assess the feasibility and plan for project implementation.

4.2.1. Site Location: The project is located at **Annexure [C4]**. The exact coordinates of the site can be found in the attached site location maps. The site is accessible via [insert access roads] and is situated in proximity to key transport hubs, making transportation of materials and equipment relatively easy.

4.2.2. Topographical and Site Conditions: The site consists of [refer Annexure [C4]]. The existing road network requires maintenance and repair works, including resurfacing, drainage improvements, and signages.

4.2.3. Site Restrictions: The Bidder must consider the following site-specific factors:

- i. **Right of Way:** Ensure access to the site without any encumbrances.
- ii. **Traffic Management:** Special consideration must be given to managing traffic during working hours, including diversions and road closures as necessary.

National Highways Infra Trust

 <p>NHIT National Highways Infra Trust</p>	<p>RFP for Providing Incident Management Vehicles</p>	<p>Doc No.: NHIT/FY25-26/RFP/ Incident Management-02</p>
---	--	---

- iii. **Space Availability:** The available area for material storage, equipment placement, and construction camps is limited and needs careful planning.

4.2.4. Location Maps:

- i. Detailed location maps, site layouts, and access points are provided in the **Annexure [C4]** for the Bidder's reference. These maps should be reviewed thoroughly to understand site boundaries, existing infrastructure, and areas of work.

4.2.5. Pre-Construction Surveys:

The Contractor is required to carry out their own survey to verify the existing conditions of the site, including sub-soil investigations, topographic surveys, and geotechnical assessments. These surveys will form the baseline for the execution of the works.

The Bidder must submit a plan for the logistics and execution of works, considering the site-specific challenges and requirements outlined above.

4.3. Environmental and Statutory Clearances

The Contractor is responsible for ensuring that all necessary environmental and statutory clearances are obtained prior to commencing any works on the project site. This section provides an overview of the clearances required and the expectations for compliance with environmental and statutory regulations.

4.3.1. Environmental Clearances:

The project must adhere to the environmental regulations set forth by the Ministry of Environment, Forest and Climate Change (MoEFCC) and other relevant authorities. The Contractor must ensure compliance with the following:

- i. **Environmental Impact Assessment (EIA):** The Contractor must obtain an EIA approval if required for the nature and scope of the work.
- ii. **Air, Water, and Noise Pollution Control:** The Contractor must implement measures to mitigate air, water, and noise pollution during the construction phase in accordance with the prescribed limits and guidelines.
- iii. **Waste Management:** The Contractor must implement a waste management plan, including the disposal of construction debris, hazardous materials, and non-hazardous waste, ensuring compliance with local regulations.

4.3.2. Statutory Clearances:

The following statutory clearances must be obtained by the Contractor before work commences:

- i. **Permits for Excavation and Groundwork:** Approvals from local authorities for any excavation and groundwork activities.
- ii. **Clearance for Traffic Diversion:** Approval from relevant traffic authorities for any required road closures or diversions during the work.
- iii. **Land Use and Building Approvals:** Any necessary approvals from local authorities regarding land use or construction work.

4.3.3. Compliance and Documentation:

The Contractor shall submit copies of all clearance certificates, permits, and approvals obtained from the relevant authorities. These documents must be provided as part of the pre-construction documentation before the commencement of the work.

4.3.4. Environmental Management Plan (EMP):

The Contractor shall prepare an Environmental Management Plan (EMP) that outlines the measures to be implemented to protect the environment throughout the project lifecycle. The EMP shall include details on waste management, pollution control, and mitigation measures for any environmental impacts identified during the pre-construction surveys. **Detailed Format for Environmental Management Plan (EMP) is given in Section 16.**

National Highways Infra Trust

	RFP for Providing Incident Management Vehicles	Doc No.: NHIT/FY25-26/RFP/ Incident Management-02
---	---	--

The Contractor shall be responsible for the timely acquisition of all necessary clearances and ensuring that the work is carried out in full compliance with environmental and statutory requirements.

National Highways Infra Trust

 National Highways Infra Trust	RFP for Providing Incident Management Vehicles	Doc No.: NHIT/FY25-26/RFP/ Incident Management-02
--	---	--

5. Terms and Conditions of Contract

5.1. General Conditions of Contract (GCC)

The General Conditions of Contract (GCC) shall govern the contractual relationship between the Employer and the Contractor, detailing the rights, obligations, and responsibilities of both parties. The GCC provides comprehensive terms covering scope, performance standards, payment terms, safety measures, dispute resolution mechanisms, and termination conditions, among other relevant provisions.

The GCC forms an integral part of this RFP and is appended as **Annexure [A1]** for reference. Bidders are advised to carefully review the GCC to ensure complete understanding and compliance. By submitting their Proposal, Bidders confirm their acceptance of the terms outlined in the GCC, except for any deviations explicitly stated and agreed upon during the bid evaluation process.

In case of any inconsistency between the provisions of this RFP and the GCC, the provisions of the GCC shall prevail unless explicitly stated otherwise in the Special Conditions of Contract (SCC) or other contractual documents.

5.2. Special Conditions of Contract (SCC)

The Special Conditions of Contract (SCC) shall supplement the General Conditions of Contract (GCC) and shall specify project-specific requirements, terms, and obligations applicable to the execution of the contract.

The SCC is designed to address particular aspects of the project, including but not limited to scope variations, additional responsibilities, payment milestones, performance security, warranties, and project timelines. In case of any conflict between the GCC and SCC, the provisions of the SCC shall prevail to the extent of such conflict.

The detailed Special Conditions of Contract are provided as an **Annexure [A2]** to this RFP document. Bidders are advised to thoroughly review the SCC and incorporate its provisions into their bids. The SCC forms an integral part of the contract and shall be binding on all parties upon the signing of the agreement.

5.3. Contract Data (Project-Specific Details)

The Contract Data provides essential project-specific details that supplement the General and Special Conditions of the Contract. These details are integral to understanding the scope, execution, and management of the contract. The Contract Data shall be referenced by all Bidders during the preparation and submission of their Bids and by the successful Bidder during project execution.

All relevant project-specific information, including but not limited to, the following, shall be included in the Contract Data and annexed to this RFP:

- a) **Project Title and Location:** A brief description of the project and its geographical location.
- b) **Scope of Work:** Outline of key deliverables, milestones, and specific requirements.
- c) **Key Dates and Timeframes:** Including Bid submission deadlines, contract commencement date, and project completion timelines.
- d) **Payment Terms:** Details regarding billing cycles, interim payments, and final settlement.

National Highways Infra Trust

	RFP for Providing Incident Management Vehicles	Doc No.: NHIT/FY25-26/RFP/ Incident Management-02
---	---	--

- e) **Performance Requirements:** Any specific performance indicators or metrics applicable to the project.
- f) **List of Minimum Equipment:** Required machinery and tools to be owned or deployed by the contractor, as applicable.
- g) **Quality Standards and Testing Protocols:** Reference to applicable standards and frequency of testing, if any.
- h) **Safety and Environmental Compliance:** Specific safety and environmental guidelines for the project.
- i) **Contact Points:** Designated representatives for communication and coordination, including their roles and responsibilities.

The detailed **Contract Data** is provided as **Annexure [C1]** of this RFP and forms an integral part of the bidding documents. Bidders are advised to review the Annexure thoroughly to ensure their Bids are compliant with the project-specific requirements. Any clarifications regarding the Contract Data must be sought in accordance with the procedure outlined in **Clause No. [2.5 – Clarifications and Addendum]** of this RFP.

National Highways Infra Trust

 <p>NHIT National Highways Infra Trust</p>	<p>RFP for Providing Incident Management Vehicles</p>	<p>Doc No.: NHIT/FY25-26/RFP/ Incident Management-02</p>
---	--	---

6. Design and Construction Requirements

6.1. Design Requirements

The Contractor shall ensure that all designs conform to:

- i. MoRTH Specifications for Road and Bridge Works (5th Revision) published by IRC.
- ii. Relevant IRC codes and guidelines.
- iii. Relevant IS codes and standards.

Design submissions must align with the project's functional and safety requirements, incorporating:

- i. Detailed design reports, calculations, and drawings for structural and non-structural components.
- ii. Safety provisions, environmental sustainability, and traffic management plans.

All design requirements are detailed in **Annexure [C5]**, which includes specific parameters and submission protocols.

6.2. Construction Requirements

All construction activities shall comply with:

- i. MoRTH Specifications for Road and Bridge Works (5th Revision).
- ii. Approved project schedules and methodologies.
- iii. Standards for material quality, workmanship, and safety.

The Contractor must ensure testing, quality assurance, and the use of appropriate equipment. Non-compliance shall be subject to penalties as specified in the contract. For further details, refer to **Annexure [C6]**.

6.3. Technical Specifications

All technical specifications shall strictly follow:

- i. MoRTH Specifications for Road and Bridge Works (5th Revision).
- ii. Relevant IRC codes for design, materials, and construction.
- iii. Relevant IS codes for materials, testing, and compliance.

The detailed technical specifications for the project are provided in **Annexure [C7]**. Any deviations require prior approval from **NHIT**.

6.4. Approved Drawings (Plans, Layouts, Sections, etc.)

The project shall be executed in strict accordance with the approved drawings, which include:

- i. General Arrangement Drawings (GAD), detailed layouts, and sections.
- ii. Structural reinforcement details and material specifications.
- iii. Utility layouts and drainage systems.

The approved drawings are appended as **Annexure [C8]**. Any revisions or updates shall be issued formally by **NHIT**.

6.5. Utility Shifting Guidelines (if applicable)

If utility shifting is part of the project scope, the Contractor shall:

National Highways Infra Trust

	RFP for Providing Incident Management Vehicles	Doc No.: NHIT/FY25-26/RFP/ Incident Management-02
---	---	--

- i. Follow the protocols outlined in MoRTH Specifications for Road and Bridge Works (5th Revision) and relevant IRC/IS codes.
- ii. Liaise with utility owners to minimize disruptions.
- iii. Ensure proper safety, environmental compliance, and timely execution.

Detailed guidelines for utility shifting, including coordination protocols and safety measures, are provided in **Annexure [A4]**.

Note

All technical specifications, drawings, and guidelines shall adhere to the latest editions of MoRTH Specifications for Road and Bridge Works (5th Revision), relevant IRC codes, and IS codes. Annexures referenced in this section are integral to the RFP document.

National Highways Infra Trust

 <p>NHIT National Highways Infra Trust</p>	<p>RFP for Providing Incident Management Vehicles</p>	<p>Doc No.: NHIT/FY25-26/RFP/ Incident Management-02</p>
---	--	---

7. Quality Assurance and Control Requirements

7.1. Standards to be Adhered to (MoRTH, IRC, IS, etc.)

Standards to be Adhered to

The Contractor shall strictly follow the latest versions of the following standards for all aspects of quality assurance and control:

1. **MoRTH Specifications for Road and Bridge Works (5th Revision):**
 - i. **Clause No. 900**, which comprehensively addresses quality management and control measures for road and bridge works.
2. **Relevant IRC Codes:**
 - i. For design, materials, and construction practices.
3. **Relevant IS Codes:**
 - i. For testing methods, material standards, and compliance procedures.

All testing, inspections, and certifications shall conform to the guidelines outlined in these codes. Where discrepancies arise, the most stringent requirement shall prevail.

7.2. Contractor's QA/QC Obligations

The Contractor is required to implement a robust QA/QC plan as per **Clause No. 900** of the **MoRTH Specifications for Road and Bridge Works (5th Revision)**, which includes but is not limited to:

1. **Establishment of a QA/QC System:**
 - i. Develop and submit a comprehensive QA/QC plan for approval prior to the commencement of works.
 - ii. Designate a dedicated QA/QC manager and support team responsible for quality management.
2. **Material Testing and Certification:**
 - i. Conduct all material testing in accordance with the relevant IRC and IS codes.
 - ii. Submit test results and certifications from approved laboratories as per project requirements.
3. **Inspection and Approval:**
 - i. Facilitate inspections by the Engineer or authorized representatives at all stages of work.
 - ii. Obtain prior approval for materials, equipment, and methodologies before use or implementation.
4. **Documentation and Reporting:**
 - i. Maintain detailed records of all QA/QC activities, including test reports, inspection logs, and certifications.
 - ii. Submit periodic quality reports to the Engineer for review and verification.
5. **Rectification of Defects:**
 - i. Address any defects or non-compliance issues promptly as identified during inspections or audits.
 - ii. Ensure that rectification measures conform to the approved standards and specifications.
6. **Site Laboratory and Testing Facilities:**
 - i. Establish a fully equipped site laboratory to conduct routine tests.
 - ii. Ensure availability of trained personnel to perform and validate tests as required.

National Highways Infra Trust

	RFP for Providing Incident Management Vehicles	Doc No.: NHIT/FY25-26/RFP/ Incident Management-02
---	---	--

Failure to comply with QA/QC obligations may lead to penalties, suspension of work, or termination of the contract, as deemed appropriate by the Employer.

National Highways Infra Trust

 <p>NHIT National Highways Infra Trust</p>	<p>RFP for Providing Incident Management Vehicles</p>	<p>Doc No.: NHIT/FY25-26/RFP/ Incident Management-02</p>
---	--	---

8. Health, Safety, and Environmental (HSE) Guidelines

This section establishes the mandatory Health, Safety, and Environmental (HSE) guidelines that the Contractor must adhere to during the execution of the project. The Contractor is obligated to implement appropriate measures to ensure the safety of workers, the protection of the environment, and compliance with statutory regulations.

8.1. HSE Requirements

The Contractor shall be responsible for ensuring the health, safety, and welfare of all persons employed or engaged in the performance of the work. Additionally, the Contractor must take all necessary precautions to protect the environment, ensure the safety of the general public, and minimize disruptions to traffic and nearby properties. Strict adherence to traffic management protocols, construction best practices, and all applicable health, safety, and environmental (HSE) regulations is mandatory. The Contractor shall comply with NHIT's HSE Policy & Requirements as detailed in **Annexure [A5]** of this RFP throughout the project duration.

The following HSE guidelines must be strictly adhered to throughout the project duration:

1. General HSE Obligations:

- i. The Contractor shall implement all necessary measures to safeguard the health and safety of workers, visitors, and any other persons who may be affected by the project activities.
- ii. The Contractor shall provide and maintain a safe working environment, free from recognized hazards that could cause injury or illness. The working conditions shall comply with all applicable national and international standards, including but not limited to the **Factories Act, 1948, The Environment Protection Act, 1986, The Occupational Safety, Health and Working Conditions Code, 2020, and International Labour Organization (ILO) standards.**
- iii. The Contractor shall conduct risk assessments regularly and take proactive steps to mitigate any identified risks. All work practices shall be reviewed periodically to ensure compliance with the latest safety regulations and standards.

2. Health and Safety Procedures:

- i. The Contractor shall establish a **Health and Safety Management Plan (HSMP)** before commencing work, detailing the procedures and controls to be implemented. The HSMP shall include procedures for emergency response, first aid, medical services, and accident reporting.
- ii. The Contractor shall provide personal protective equipment (PPE) to all workers and ensure its proper use. PPE includes, but is not limited to, helmets, safety boots, gloves, goggles, ear protection, and high-visibility clothing.
- iii. The Contractor shall ensure that all workers are adequately trained on health and safety protocols, emergency procedures, and the proper use of equipment. Regular safety drills and training sessions must be conducted and documented.
- iv. A **Health and Safety Officer** shall be appointed to oversee the implementation of the HSMP and ensure compliance with all safety regulations. The Health and Safety Officer will be responsible for reporting safety violations and making recommendations for corrective actions.

3. Emergency Preparedness:

National Highways Infra Trust

 <p>NHIT National Highways Infra Trust</p>	<p>RFP for Providing Incident Management Vehicles</p>	<p>Doc No.: NHIT/FY25-26/RFP/ Incident Management-02</p>
---	--	---

- i. The Contractor shall establish emergency response procedures for various contingencies, including fire, medical emergencies, natural disasters, and accidents. These procedures must be communicated to all personnel, and emergency response drills shall be conducted periodically.
- ii. A **first-aid kit** and emergency medical services shall be readily available at the worksite. The Contractor must ensure that all workers are familiar with the location of the emergency facilities and the procedures for requesting emergency assistance.
4. **Reporting and Record-Keeping:**
 - i. The Contractor shall maintain comprehensive records of all health and safety incidents, including accidents, injuries, near-misses, and corrective actions taken. These records must be submitted regularly to the Employer for review.
 - ii. In case of any significant accident or incident, the Contractor shall provide an immediate report to the Employer and the relevant authorities, along with a detailed investigation into the cause and corrective measures.
5. **Subcontractor Compliance:**
 - i. The Contractor shall ensure that all subcontractors engaged in the project adhere to the same high standards of health and safety. The Contractor shall be responsible for ensuring that subcontractors comply with the HSE requirements and shall monitor their performance accordingly.
6. **Non-Compliance Penalties:**
 - i. Failure to comply with the HSE guidelines may result in penalties, work stoppages, or contract termination. The Employer reserves the right to take corrective action in case of persistent non-compliance.

8.2. Environmental Management Plan (EMP)

The Contractor shall prepare and implement an **Environmental Management Plan (EMP)** to ensure the project is executed in a manner that minimizes environmental impact. The EMP shall detail the specific actions to be taken to mitigate adverse environmental effects arising from the project and ensure compliance with environmental regulations. **Detailed Format for Environmental Management Plan (EMP) is given in Section 16.**

1. **General Environmental Obligations:**
 - i. The Contractor shall comply with all relevant environmental laws, regulations, and guidelines, including those set by the **Ministry of Environment, Forest and Climate Change (MoEFCC)**, the **Environmental Protection Act, 1986**, and **State Pollution Control Boards**. The EMP must be designed in accordance with these regulations to minimize pollution and protect natural resources.
 - ii. The EMP must include provisions for environmental monitoring and compliance audits to assess the project's adherence to environmental standards and regulations.
2. **Mitigation of Environmental Impacts:** The EMP shall address the following environmental impacts, among others:
 - i. **Air Quality:** Measures to control dust, emissions from vehicles, and other pollutants during construction activities. Dust suppression techniques, such as water spraying and the use of dust barriers, shall be implemented.
 - ii. **Water Quality:** The Contractor shall ensure that water bodies in and around the project area are protected from contamination due to construction activities. Measures shall be

National Highways Infra Trust

 <p>NHIT National Highways Infra Trust</p>	<p>RFP for Providing Incident Management Vehicles</p>	<p>Doc No.: NHIT/FY25-26/RFP/ Incident Management-02</p>
---	--	---

taken to manage runoff, prevent spillage of hazardous materials, and treat wastewater as per legal requirements.

- iii. **Waste Management:** The Contractor shall implement a waste management strategy that includes the collection, segregation, recycling, and disposal of waste materials. Hazardous and non-hazardous wastes must be handled separately, with proper disposal methods to avoid environmental harm.
 - iv. **Noise and Vibration:** The Contractor shall take necessary precautions to limit noise and vibration levels at the site. The use of noise barriers, the maintenance of machinery, and compliance with permissible noise limits shall be part of the mitigation measures.
 - v. **Ecological Impact:** If the project site affects flora and fauna, the EMP shall include a detailed plan for the conservation of biodiversity, including the protection of existing vegetation, wildlife, and endangered species.
3. **Monitoring and Compliance:**
- i. The Contractor shall conduct regular environmental monitoring to assess the effectiveness of the mitigation measures and identify any unforeseen environmental impacts.
 - ii. Environmental audits shall be conducted at regular intervals, and the Contractor shall submit the results of these audits to the Employer.
 - iii. The Contractor shall cooperate with the authorities and provide access to the site for inspection of environmental compliance.
4. **Waste Disposal and Resource Management:**
- i. The Contractor shall ensure the proper disposal of construction debris and hazardous materials in compliance with relevant environmental guidelines.
 - ii. The EMP shall include measures for resource conservation, such as energy-efficient construction methods, use of sustainable materials, and water conservation during the execution of the project.
5. **Emergency Response for Environmental Incidents:**
- i. In the event of an environmental accident, such as a chemical spill or fuel leak, the Contractor shall have a response plan in place, including immediate containment measures, notification procedures, and mitigation actions. The Employer shall be notified immediately, and corrective actions must be taken to prevent further damage.
6. **Environmental Training:**
- i. The Contractor shall provide environmental awareness training to all workers and subcontractors involved in the project. This training shall focus on the importance of environmental protection, waste management, and the proper use of equipment to minimize environmental impacts.
7. **Reporting and Documentation:**
- i. The Contractor shall maintain detailed records of all environmental activities, including waste management, emissions control, and monitoring results. These records shall be made available to the Employer and relevant authorities upon request.
8. **Compliance Audits:**
- i. The Employer reserves the right to conduct independent environmental compliance audits, at their discretion, to assess the Contractor's adherence to the EMP. If the

National Highways Infra Trust

 National Highways Infra Trust	RFP for Providing Incident Management Vehicles	Doc No.: NHIT/FY25-26/RFP/ Incident Management-02
--	---	---

Contractor is found to be non-compliant, corrective measures shall be required within a specified time frame.

National Highways Infra Trust

 National Highways Infra Trust	RFP for Providing Incident Management Vehicles	Doc No.: NHIT/FY25-26/RFP/ Incident Management-02
--	---	---

9. Financial Proposal

9.1 Format for Financial Bid Submission

<On the Letterhead of the Bidder>

FINANCIAL PROPOSAL

From:

<Name and Address of the Bidder>

To:

Mr. [name & designation shall be as specified in Contract Data Sheet]

National Highways Infra Trust

Unit No.: 325, 3rd Floor, D21 - Corporate Park

Sector-21, Dwarka, Delhi - 110077

Subject: Financial Proposal for the Request for Proposal (“RFP”) issued by National Highways Infra Trust (NHIT) for Engagement of Agency/Firm for Providing Incident Management Vehicles at Project sites under SPVs of NHIT.

FINANCIAL OFFER

The financial offer, inclusive of all costs except GST, is presented below:

Sr. No.	Particulars	Amount (INR)
1	Refer Annexure [C3]	

Note: A detailed cost breakup is provided in the attached Bill of Quantities (BoQ).

Name & Signature of Bidder’s Authorized Signatory

Date:

Instructions for Bidders

1. The financial offer must be quoted in Indian Rupees, limited to two decimal places, and shall remain firm throughout the contract period.
2. The quoted fee must be inclusive of all charges except GST, which will be paid as applicable. Taxes should be shown separately while submitting invoices for payment.
3. Withholding taxes, as applicable, will be deducted at the time of payment.
4. A detailed BoQ with cost breakup should accompany this proposal.

9.2 Payment Schedule

The payment schedule for the works shall be governed by the provisions outlined in the **Contract Data Sheet** and shall conform to the terms specified in the General Conditions of Contract (GCC) and Special Conditions of Contract (SCC). Payments may be structured as either **Milestone-Based** or **BoQ-Based**, as defined in the Contract Data.

National Highways Infra Trust

 <p>NHIT National Highways Infra Trust</p>	<p>RFP for Providing Incident Management Vehicles</p>	<p>Doc No.: NHIT/FY25-26/RFP/ Incident Management-02</p>
---	--	---

- **Milestone-Based Payments:** Payments shall correspond to the measurable and certified completion of specific activities or project milestones, as defined in the approved Scope of Work and the agreed construction program. The certification of milestones by the Engineer/Authority's Representative shall be mandatory for processing payment claims.
- **BoQ-Based Payments:** Payments shall be made against the actual quantities of work executed, measured, and certified as per the mode of measurement specified in the Contract Data and BoQ. The contractor shall submit Interim Payment Certificates (IPCs) based on quantities executed, supported by appropriate documentation, including detailed measurement sheets and verification reports. Payment shall be made at the agreed unit rates for the items specified in the BoQ, subject to the terms of the Contract.

For both methods, advance payments, if applicable, shall be disbursed upon submission of an acceptable Advance Payment Bank Guarantee. Deductions for retention money, performance securities, liquidated damages, and any other amounts stipulated in the Contract shall apply uniformly.

The final payment shall be released upon successful completion of all contractual obligations, including rectification of defects during the Defects Liability Period (DLP), submission of "As-Built Drawings," and certification of the Final Payment Certificate by the Engineer/Authority's Representative. Payments shall be processed within the timelines specified in the Contract and shall be subject to compliance with all contractual conditions.

9.3 Bill of Quantities

The Bill of Quantities (BoQ) provided in the **Annexure [C3]** forms an integral part of the Contract and specifies the estimated quantities, unit rates, and total cost for each item of work. The contractor is required to execute the works strictly in accordance with the BoQ, the drawings, and the technical specifications outlined in the Contract.

The quantities mentioned in the BoQ are indicative and subject to variations as per the provisions of the GCC. The contractor shall not execute quantities beyond the variation limits stipulated in the Contract Data without prior written approval from the Authority.

The Engineer/Authority's Representative shall certify all measurements and variations in accordance with the specified mode of measurement. Payment for items shall be made at the agreed unit rates for the actual work done, as certified.

The contractor shall ensure proper documentation and submission of records, including daily progress reports, to support all claims under the BoQ. Any disputes related to measurements or quantities shall be resolved as per the provisions of the Dispute Resolution Mechanism in the Contract.

9.4 Right to Renegotiate or Re-Tender

The Client reserves the right to renegotiate the prices or initiate a separate tendering process if the total contract value or the executed quantities exceed the limits specified in the Contract Data Sheet. In the event that no such limits are provided in the Contract Data Sheet, the limit shall be **125% of the total contract value** and **125% for any specific item**.

The Contractor shall not claim any automatic entitlement to execute additional quantities beyond the agreed contractual limits. Any renegotiation or additional award shall be subject to mutual agreement and approval by the Client.

National Highways Infra Trust

 National Highways Infra Trust	RFP for Providing Incident Management Vehicles	Doc No.: NHIT/FY25-26/RFP/ Incident Management-02
--	---	--

9.5 Taxation Details

The Contractor shall be solely responsible for the payment of all applicable taxes, duties, levies, and other statutory charges, whether existing or arising during the Contract period, except for Goods and Services Tax (GST), which shall be paid separately by the Authority at the prevailing rates.

The Contractor shall issue GST-compliant tax invoices for every claim, incorporating their valid GST Registration Number and the applicable GST rates. Any input tax credits availed by the Authority shall be adjusted against payments due to the Contractor. Failure to comply with GST regulations, including timely submission of invoices and returns, shall result in penalties as provided under the governing laws and the Contract.

The Contractor shall indemnify the Authority against any liabilities, losses, or penalties arising out of non-compliance with applicable tax laws. If there is any change in applicable tax laws or the introduction of new taxes during the Contract period, such changes shall be dealt with in accordance with the GCC.

It shall be the Contractor's obligation to ensure compliance with all statutory requirements and provide evidence of tax deposits upon request by the Authority. Any tax-related disputes shall be handled in accordance with the provisions of the Contract and the applicable laws of the jurisdiction.

10. Performance and Security Documents

10.1 Performance Security Template (Annexure [B2])

The Contractor shall furnish a Performance Security in the form of an unconditional and irrevocable Bank Guarantee issued by a Scheduled Commercial Bank in India or any other bank acceptable to the Authority, in the format provided in the Contract Data. The Performance Security shall be submitted within the timeline stipulated in the Letter of Acceptance (LOA) and prior to the signing of the Contract Agreement.

The amount of the Performance Security shall be equivalent to the percentage of the Accepted Contract Amount as specified in the Contract Data and shall remain valid until the expiry of the Defects Liability Period (DLP) or any extension thereof, including an additional claim period of 60 (sixty) days.

In the event of the Contractor's failure to perform any of its obligations under the Contract, the Authority shall have the right to invoke the Performance Security, either in part or in full, without prior notice to the Contractor. Such invocation shall not absolve the Contractor from its contractual obligations or liabilities.

The Contractor shall ensure that the Performance Security is renewed or replaced as and when required, to maintain its validity as per the Contract terms. Failure to maintain valid Performance Security shall be treated as a material breach, entitling the Authority to take appropriate action, including termination of the Contract.

10.2 Bank Guarantee Template (for Advance Payment) (Annexure [B3])

If an advance payment is agreed upon, the Contractor shall furnish an Advance Payment Bank Guarantee (APBG) in the prescribed format provided in the Contract Data. The APBG shall be issued by a Scheduled Commercial Bank in India or any other bank acceptable to the Authority, and it shall be equivalent to the amount of the advance payment sanctioned under the Contract.

National Highways Infra Trust

 <p>NHIT National Highways Infra Trust</p>	<p>RFP for Providing Incident Management Vehicles</p>	<p>Doc No.: NHIT/FY25-26/RFP/ Incident Management-02</p>
---	--	---

The APBG shall be unconditional and irrevocable, ensuring repayment of the advance payment in the event of default by the Contractor. The guarantee shall remain valid until the advance payment is fully adjusted against interim payments or until the date specified in the Contract Data, whichever is earlier.

The Authority shall have the right to invoke the APBG, either partially or fully, if the Contractor fails to utilize the advance payment for the intended purpose, defaults in executing the Works, or breaches any terms of the Contract.

The advance payment shall be recovered progressively from the Contractor's Interim Payment Certificates (IPCs) as per the recovery schedule specified in the Contract Data. The recovery of the advance payment shall commence from the first IPC and shall be completed before the value of work executed reaches 80% of the Accepted Contract Amount.

The Contractor shall ensure timely renewal or extension of the APBG to maintain its validity as required under the Contract. Any failure to provide or maintain a valid APBG shall result in suspension of payments to the Contractor and may lead to termination of the Contract.

11. Supplementary Information for Bidders

11.1 Draft Contract Agreement

The Draft Contract Agreement forms an integral part of this Request for Proposal (RFP) document. It outlines the comprehensive terms and conditions governing the execution of the project, including but not limited to, the obligations of the parties, payment terms, scope of work, timelines, quality assurance requirements, performance security, and provisions for dispute resolution.

The Draft Contract Agreement is attached as **Annexure [C9]** for reference and must be carefully reviewed by all bidders to ensure full understanding and compliance. Any deviations or modifications to the terms of the Draft Contract Agreement will not be entertained post-award unless expressly agreed upon by the Authority.

By submitting their bids, bidders confirm their unconditional acceptance of the terms and conditions stipulated in the Draft Contract Agreement. The successful bidder will be required to execute this agreement in its present form, subject to any project-specific amendments as notified by the Authority.

11.2 List of Approved Vendors (wherever applicable)

The List of Approved Vendors, as specified by the NHIT, **comprises manufacturers, suppliers, and service providers approved for the procurement of materials, equipment, and services required for the project.** This list ensures compliance with prescribed quality standards, enhances reliability, and promotes efficiency in project execution.

The successful bidder shall procure materials and services exclusively from the vendors listed in **Annexure [A3]**, unless prior written approval is obtained from the Authority for alternate vendors. Any deviation from this requirement without authorization may result in penalties or other remedial actions as deemed appropriate by the Authority.

The bidders are advised to review the List of Approved Vendors in **Annexure [A3]** to assess the availability and suitability of vendors for the project's specific requirements. This list is subject to periodic revisions, and the Authority reserves the right to amend or update the list during the execution of the contract, as necessary.

National Highways Infra Trust

 <p>NHIT National Highways Infra Trust</p>	<p>RFP for Providing Incident Management Vehicles</p>	<p>Doc No.: NHIT/FY25-26/RFP/ Incident Management-02</p>
---	--	---

11.3 Dispute Resolution Mechanism (Clause No. 18 of GCC)

Dispute Notification and Procedure

The Contractor shall notify the Client in writing within 7 days of the occurrence of any dispute, difference, or claim that requires resolution. The notice should clearly detail the nature of the dispute, relevant facts, and the legal or factual basis for the claim. Upon receipt of the dispute notice, the Client and Contractor shall engage in discussions for a period not exceeding 30 days to attempt an amicable settlement.

11.3.1 Amicable Settlement

In the event of any dispute, difference, or claim arising between the Client and the Contractor in connection with or related to the Contract, the parties shall first attempt to resolve such dispute amicably through mutual consultation and negotiation. The party initiating the dispute (the "Notifying Party") shall notify the other party in writing, clearly outlining the nature and scope of the dispute. Both parties shall make all reasonable efforts to settle the dispute, amicably, within 30 days from the date of notification.

If the dispute remains unresolved after this period, the decision of the Client's CEO shall be final and binding on both parties. Should the decision of the Client's CEO not be acceptable, and the dispute persists, the matter shall proceed to the Dispute Resolution process as outlined below.

11.3.2 Dispute Resolution Board (DRB)

If the dispute remains unresolved after the amicable settlement period, the dispute shall be referred to a Dispute Resolution Board (DRB).

- a) The DRB will be constituted solely from the senior management team of the Client at its Head Office (HO). No external person or third party will be involved in this process.
- b) The DRB shall be tasked with reviewing the dispute and providing a recommendation or resolution within 45 days from the date the dispute is referred to it. The decision of the DRB shall be binding on both parties unless challenged under the Arbitration **Clause No. 11.3.4** below.
- c) In the event the DRB fails to resolve the dispute within the prescribed time, or if either party is dissatisfied with the DRB's decision, the dispute will proceed to arbitration.

11.3.3 Arbitration

If the dispute remains unresolved after mediation, the dispute shall be referred to and resolved through arbitration in accordance with the provisions of the Arbitration and Conciliation Act, 1996, as amended from time to time.

- a) **In cases where the disputed amount is up to INR 1.5 Crore**, the arbitration shall be conducted by a sole arbitrator appointed by the Client.
- b) **In cases where the disputed amount exceeds INR 1.5 Crore**, three arbitrators shall be appointed. One arbitrator shall be appointed by the Client, one by the Contractor, and the third arbitrator shall be appointed by the two previously appointed arbitrators. In case the two arbitrators fail to agree on the appointment of the third arbitrator, the third arbitrator shall be appointed by the relevant arbitration institution in New Delhi.

National Highways Infra Trust

 <p>NHIT National Highways Infra Trust</p>	<p>RFP for Providing Incident Management Vehicles</p>	<p>Doc No.: NHIT/FY25-26/RFP/ Incident Management-02</p>
---	--	---

- c) The arbitration proceedings shall be held in New Delhi, India, and the language of arbitration shall be English. The arbitrator's decision shall be final and binding on both parties. The cost of arbitration, including the arbitrator's fees, shall be borne equally by the parties unless otherwise awarded by the arbitrator.

11.3.4 Jurisdiction and Venue

The courts at Delhi, India, shall have exclusive jurisdiction over all disputes and legal proceedings arising from or relating to the Contract. Both parties expressly consent to the jurisdiction of the courts at Delhi for the purpose of enforcement of any judgment or award.

11.3.5 Interim Relief

Notwithstanding the above, either party may seek interim relief from a court of competent jurisdiction at any time before or during the dispute resolution process, in order to preserve its rights or prevent any irreparable damage or harm.

11.3.6 No Suspension of Work

The Contractor shall continue with the performance of its obligations under the Contract, including the Works, during the dispute resolution process unless the Client has issued a formal suspension order. Non-payment of money or non-performance of obligations by the Client shall not relieve the Contractor of its responsibilities to continue the work.

11.4 List of Applicable Laws and Standards

The execution of this project, including all associated works, obligations, and deliverables, shall conform to the following applicable laws, regulations, and standards. The list provided herein is exhaustive but not limited to the mentioned items. It shall be the contractor's responsibility to ensure compliance with all applicable statutory and technical requirements, whether explicitly mentioned or not:

11.4.1 Applicable Laws:

11.4.1.1 General and Contractual Laws:

- The Indian Contract Act, 1872
- The Arbitration and Conciliation Act, 1996

11.4.1.2 Labour and Employment Laws:

- The Minimum Wages Act, 1948
- The Payment of Wages Act, 1936
- The Employees' Provident Funds and Miscellaneous Provisions Act, 1952
- The Workmen's Compensation Act, 1923
- The Contract Labour (Regulation and Abolition) Act, 1970
- The Building and Other Construction Workers' Welfare Cess Act, 1996.

11.4.1.3 Taxation Laws:

- The Goods and Services Tax (GST) Act, 2017
- The Income Tax Act, 1961

11.4.1.4 Environmental Protection Laws:

National Highways Infra Trust

 <p>NHIT National Highways Infra Trust</p>	RFP for Providing Incident Management Vehicles	Doc No.: NHIT/FY25-26/RFP/ Incident Management-02
---	---	--

- The Environment (Protection) Act, 1986
- The Water (Prevention and Control of Pollution) Act, 1974
- The Air (Prevention and Control of Pollution) Act, 1981

11.4.1.5 **Transport and Safety Laws:**

- The Motor Vehicles Act, 1988
- The Factories Act, 1948

11.4.1.6 **Any other laws, regulations, or rules:**

Any additional laws, rules, or guidelines enacted by the Government of India, State Governments, or relevant statutory bodies that are applicable to this project.

11.4.2 **Standards and Technical Specifications:**

11.4.2.1 **National Standards:**

- Specifications for Road and Bridge Works (Latest Revision), Ministry of Road Transport and Highways (MoRTH)
- Indian Roads Congress (IRC) Standards and Guidelines
- Bureau of Indian Standards (BIS) relevant to construction, material specifications, and safety

11.4.2.2 **International Standards (if specified):**

- ISO standards for quality, safety, and management systems
- ASTM or EN standards for material testing and equipment where applicable

11.4.2.3 **Project-Specific Standards:**

- Any additional standards explicitly mentioned in the RFP, contract documents, or technical schedules.

11.4.3 **Contractor's Responsibility:**

It is the contractor's responsibility to ensure strict compliance with all applicable laws, standards, and guidelines, whether listed above or otherwise applicable by the nature of the project.

11.4.4 **Jurisdiction and Dispute Resolution (Clause No. 17 of GCC):**

This Agreement shall be governed by, and construed in accordance with, the laws of India. The parties hereby agree that any disputes, claims, or controversies arising out of or in connection with this Agreement, including its validity, interpretation, enforcement, or performance, shall be subject to the exclusive jurisdiction of the courts in New Delhi, India.

The parties consent to the jurisdiction of the courts of New Delhi and waive any objections based on venue or forum non convenience. All legal proceedings under this Agreement shall be conducted in the English language.

11.5 **Pre-Bid Meeting Minutes (if issued as an addendum)**

The Procuring Authority shall convene a Pre-Bid Meeting as specified in the **Contract Data Sheet** to address any queries or clarifications raised by the prospective Bidders regarding the RFP documents. The minutes of the Pre-Bid Meeting, including responses to the queries and any amendments to the RFP, if applicable, shall be recorded and circulated to all Bidders who have downloaded or purchased the RFP.

The Pre-Bid Meeting Minutes shall form an integral part of the RFP documents and shall be binding on all Bidders. Bidders are advised to review the minutes and ensure that their proposals are in conformity

National Highways Infra Trust

 <p>NHIT National Highways Infra Trust</p>	<p>RFP for Providing Incident Management Vehicles</p>	<p>Doc No.: NHIT/FY25-26/RFP/ Incident Management-02</p>
---	--	---

with the clarifications and amendments issued. No separate communication shall be entertained on matters addressed in the Pre-Bid Meeting Minutes.

Any updates to the RFP pursuant to the Pre-Bid Meeting shall be issued through an Addendum and published as per the procedure outlined in **Clause No. 2.5 for Amendments/Communications**.

11.6 Corrigendum/Addendum to RFP (if issued)

The Procuring Authority reserves the right to amend, modify, or supplement the RFP documents at any stage prior to the submission deadline. Such amendments, modifications, or supplements shall be issued in the form of a Corrigendum or Addendum.

The Corrigendum/Addendum to the RFP shall be uploaded on the official website as specified in the Data Sheet and/or communicated to all Bidders who have purchased or downloaded the RFP. Bidders are advised to regularly visit the official website and review all issued Corrigendum/Addendum to stay updated.

The procedure for issuing Corrigendum/Addendum shall be as follows:

- a) Any clarifications, modifications, or changes to the RFP shall be recorded in writing and approved by the competent authority of the Procuring Authority.
- b) A formal notification of the Corrigendum/Addendum, along with the updated sections of the RFP, shall be published on the official website and circulated to registered Bidders.
- c) The Corrigendum/Addendum shall form an integral part of the RFP and be binding on all Bidders.
- d) The timeline for submission of bids may be extended if the nature of the Corrigendum/Addendum necessitates additional preparation time for Bidders, at the sole discretion of the Procuring Authority.

No further communication on issued Corrigendum/Addendum shall be entertained. It is the sole responsibility of the Bidders to ensure compliance with the updated RFP requirements.

National Highways Infra Trust

 <small>National Highways Infra Trust</small>	RFP for Providing Incident Management Vehicles	Doc No.: NHIT/FY25-26/RFP/ Incident Management-02
---	---	---

12 Information Required to Evaluate the Bid Capacity

12.1 Calculation of "A" and "C"

To determine the value of "A" and "C" for Bid Capacity evaluation under **Clause 2.2.7 (Bid Capacity Calculation)**, the bidder must provide details of Civil Engineering Works undertaken in respect of EPC Projects (Turnkey Projects / Item Rate Contracts / Construction Works) during the last three financial years. The amount of bonus received, if any, shall be indicated separately.

The **Net Value Excluding Bonus** shall be derived as **(3) = (1) - (2)**.

Sl. No.	Financial Year	Value of Civil Engineering Works in EPC Projects (₹ Crores) (1)	Amount of Bonus (₹ Crores) (2)	Net Value Excluding Bonus (₹ Crores) (3) = (1) - (2)
1	2023-24/2023			
2	2022-23/2022			
3	2021-22/2021			

The maximum value of projects undertaken in a single financial year from the last three years, excluding any bonus amount, is ₹ _____ Crores (Rupees _____). This value, updated to the price level of the year indicated in Appendix, is calculated as follows:

₹ _____ Crores * _____ (Updation Factor as per Appendix) = ₹ _____ Crores (Rupees _____).

The total amount of bonus received, if any, in EPC Projects during the last three years (updated to the price level of the year indicated in Appendix) is as follows:

Sl. No.	Financial Year / Calendar Year	Amount of Bonus (₹ Crores) (1)	Updation Factor (2)	Updated Amount of Bonus (₹ Crores) (3) = (1) * (2)
1	2023-24/2023		1.00	
2	2022-23/2022		1.05	
3	2021-22/2021		1.10	
	Total (C)			

12.2 Calculation of "B"

The bidder must provide details of all existing commitments and ongoing works to be completed in the next **9 months**.

Sl. No.	Name of Project / Work	% Participation of Bidder in Project	Date of Issue of LOA / Date of Opening of Financial Bid / Date of Start / Appointed Date	Construction Period as per Agreement / LOA	Contract Value as per Agreement / LOA (₹ Crores)	Value of Work Completed (₹ Crores)	Balance Value of Work to be Completed (₹ Crores) (1)	Anticipated Date of Completion	Balance Value of Work at 2023-24/2023 Price Level (₹ Crores) (2) = (1) * Updation Factor

National Highways Infra Trust

 <small>National Highways Infra Trust</small>	RFP for Providing Incident Management Vehicles	Doc No.: NHIT/FY25-26/RFP/ Incident Management-02
---	---	---

1									
2									
3									
	Total								

The **Updation Factor** to be applied is as follows:

Sl. No.	Financial Year / Calendar Year	Updation Factor
1	2023-24/2023	1.00
2	2022-23/2022	1.05
3	2021-22/2021	1.10

The bidder must provide a **verified statement** of all existing commitments, awarded works, and anticipated value of work to be completed during the construction period of the project for which the bid is invited. This statement must be **countersigned by the Client or its Engineer-in-Charge (not below the rank of Executive Engineer) for EPC Projects or by the Concessionaire / Authorized Signatory of SPV for BOT Projects.**

No awarded or ongoing work has been excluded from this statement for M/s _____, either individually or in a Joint Venture with M/s _____ and M/s _____, as on the bid due date of this RFP.

Note:

- i. If the balance period of construction is **less than** the construction period of the project for which the bid is invited, the **full contract value** as per Agreement/LOA shall be mentioned.
- ii. If the balance period of construction is **more than** the construction period of the project for which the bid is invited, only the **anticipated value of work to be completed** shall be mentioned.
- iii. If the anticipated value of work to be completed is not provided, the **proportionate value** shall be considered while evaluating the **Assessed Available Bid Capacity**.

Date: _____

Place: _____

National Highways Infra Trust

 <p>NHIT National Highways Infra Trust</p>	<p>RFP for Providing Incident Management Vehicles</p>	<p>Doc No.: NHIT/FY25-26/RFP/ Incident Management-02</p>
---	--	---

13 Miscellaneous Provisions

13.1 Force Majeure Clause No. (Clause No. 19 of GCC)

Definition

Force Majeure shall mean any extraordinary event or circumstance beyond the reasonable control of the affected party that prevents or delays the performance of its contractual obligations. These events may include, but are not limited to, acts of God, natural disasters (such as floods, earthquakes, or storms), acts of war, terrorism, riots, civil commotion, government orders, pandemics, or any other unforeseen event that cannot be mitigated through reasonable diligence.

Notification

The party affected by a Force Majeure event shall notify the other party in writing within seven (7) days of the occurrence of such an event, providing reasonable details of its nature, likely duration, and impact on performance. Failure to notify within this period may result in the loss of the right to claim Force Majeure relief.

13.1.1 Consequences of Force Majeure

- (a) The obligations of the affected party shall be suspended for the duration of the Force Majeure event, to the extent that they are directly impacted by it.
- (b) Both parties shall use all reasonable efforts to mitigate the effect of the Force Majeure event and resume performance of their obligations as soon as practicable.
- (c) If the Force Majeure event continues for a period exceeding ninety (90) days, either party may terminate the contract upon written notice to the other party.

13.1.2 Exclusions

Force Majeure shall not include:

- (a) Any event caused by the negligence or intentional act of the affected party.
- (b) Economic hardship, changes in market conditions, or lack of funds.

13.1.3 Extension of Time

If the Contractor's performance is delayed due to a Force Majeure event, the Contractor shall be entitled to an extension of time equivalent to the period of delay, subject to approval by the Client.

13.1.4 Payments During Force Majeure

The Contractor shall not be entitled to claim compensation or additional payments due to Force Majeure events unless explicitly agreed upon in the contract or otherwise required under applicable law.

13.1.5 Final Determination

Any disputes regarding the application of this **Clause No.** shall be resolved in accordance with **Clause No. 18 of GCC** (Dispute Resolution).

13.2 Termination Conditions (Clause No. 20 of GCC)

13.2.1 Termination by the Client

The Client may terminate the Contract, in whole or in part, with immediate effect or after a specified notice period, in the following circumstances:

- 13.2.2 **Non-Performance:** If the Contractor fails to meet contractual obligations, including delays or substandard performance, after receiving a written notice to cure the breach within a period specified in the Contract.

National Highways Infra Trust

 <p>NHIT National Highways Infra Trust</p>	RFP for Providing Incident Management Vehicles	Doc No.: NHIT/FY25-26/RFP/ Incident Management-02
---	---	--

- 13.2.3 **Breach of Terms:** In case of material violation of any terms or conditions of the Contract, including but not limited to safety standards, statutory compliance, or quality assurance requirements.
- 13.2.4 **Insolvency:** If the Contractor becomes insolvent, enters into bankruptcy proceedings, or undergoes dissolution, liquidation, or similar financial distress events.
- 13.2.5 **Force Majeure:** If Force Majeure conditions continue for more than ninety (90) days, making further performance impracticable.
- 13.2.6 **Convenience of the Client: The Client reserves the right to terminate the Contract for** convenience, provided reasonable compensation for work performed up to the date of termination is made.
- 13.2.7 **Termination for Default:**

In case of default by the Contractor, the Client reserves the right to terminate the Contract, either in whole or in part, by giving written notice. Default includes the following:

- a) **Non-Performance:** Failure to meet key contractual obligations, including delays in execution or substandard work, despite receiving a notice to cure within a period specified in the Contract.
- b) **Breach of Terms:** Failure to comply with any material provisions of the Contract, including statutory, safety, or quality assurance requirements.
- c) **Insolvency or Financial Distress:** If the Contractor enters into insolvency, bankruptcy, liquidation, or similar financial distress, or any situation that materially impacts its ability to fulfil its obligations under this Contract.

13.2.8 Upon such termination, the following shall apply:

- a) **Notice to Cure:** A written notice shall be issued to the Contractor, specifying the nature of the default. The Contractor will be granted a cure period of 15 days (or as specified in the Special Conditions of Contract) to remedy the default. Failure to rectify the default within the cure period will lead to immediate termination.
- b) **Penalties and Compensation:** The Client may impose penalties of up to **10% of the Contract value** for non-performance or failure to meet standards. The Contractor shall be liable to compensate the Client for any costs incurred due to the default, including but not limited to the cost of procuring alternate contractors to complete the work.
- c) **Withholding of Payments:** The Client has the right to withhold payments corresponding to incomplete, defective, or unsatisfactory work performed prior to termination.

Termination under this **Clause No.** is without prejudice to any other legal or contractual rights available to the Client, including claims for damages and performance guarantees.

13.2.9 Termination by the Contractor

The Contractor may terminate the Contract by providing a written notice, subject to fulfilling its obligations until the termination date, in the following circumstances:

Non-Payment: If the Client fails to pay undisputed invoices for a period exceeding One Hundred & Eighty (180) days after they become due, despite receiving written notice.

Client Hindrance: If the Client repeatedly obstructs the Contractor's performance by failing to provide access, approvals, or other essential resources as specified in the Contract.

Force Majeure: If Force Majeure conditions persist beyond Ninety (90) days, rendering performance impossible.

National Highways Infra Trust

	RFP for Providing Incident Management Vehicles	Doc No.: NHIT/FY25-26/RFP/ Incident Management-02
---	---	--

13.2.10 Procedure for Termination

Notice of Intent: A party initiating termination shall issue a formal written notice detailing the grounds for termination and the intended termination date, allowing a minimum of thirty (30) days for remedial action unless otherwise specified.

Efforts to Resolve: The parties shall engage in good-faith discussions during the notice period to address and resolve the stated issues.

Confirmation of Termination: If the issues remain unresolved by the end of the notice period, the initiating party shall issue a final termination notice, effectively ending the Contract.

13.2.11 Post-Termination Obligations

Cease Work: The Contractor shall cease all work immediately except for activities required to protect the works already executed or to comply with statutory obligations.

Return of Assets: All equipment, materials, designs, and other assets belonging to the Client shall be returned or securely handed over within seven (7) days of termination.

Payments: The Client shall settle payments for verified work performed up to the termination date, subject to deductions for any damages, penalties, or liabilities.

13.2.12 Liabilities Upon Termination

Contractor's Liabilities: The Contractor shall bear the cost of demobilization, removal of equipment, and site clearance unless otherwise agreed.

Client's Liabilities: In cases of termination for convenience, the Client shall pay reasonable compensation for expenses directly attributable to the termination. Reasonable compensation is limited to:

Costs for completed works and verified quantities based on contract rates.

Documented and substantiated costs for materials procured specifically for the project, provided these materials are handed over to the Client.

Actual and reasonable costs incurred for demobilization and site clearance.

Compensation shall exclude anticipated profits on unexecuted work, costs due to the Contractor's default, and any claims not supported by documentary evidence. Total compensation shall not exceed 10% of the original contract value. Claims for compensation must be submitted within 30 days of termination with all supporting documents, subject to verification by the Client.

13.2.13 Survival of Provisions

The provisions relating to confidentiality, indemnities, dispute resolution, warranties, and any other obligations expressly stated to survive termination or expiration of this Agreement shall remain in full force and effect.

13.2.14 Dispute Arising from Termination

Any disputes related to or arising from termination shall be resolved as per **Clause No. 18** of GCC (Dispute Resolution).

National Highways Infra Trust

 National Highways Infra Trust	RFP for Providing Incident Management Vehicles	Doc No.: NHIT/FY25-26/RFP/ Incident Management-02
--	---	--

13.3 Governing Law and Jurisdiction

This Agreement shall be governed by, and construed in accordance with, the laws of India. The parties hereby agree that any disputes, claims, or controversies arising out of or in connection with this Agreement, including its validity, interpretation, enforcement, or performance, shall be subject to the exclusive jurisdiction of the courts in New Delhi, India.

The parties consent to the jurisdiction of the courts of New Delhi and waive any objections based on venue or forum non convenience. All legal proceedings under this Agreement shall be conducted in the English language.

National Highways Infra Trust

 <p>NHIT National Highways Infra Trust</p>	RFP for Providing Incident Management Vehicles	Doc No.: NHIT/FY25-26/RFP/ Incident Management-02
---	---	---

14 Undertaking

Undertaking

<On the Letterhead of the Bidder>

To be submitted with the Technical Bid

Request for Proposal (“RFP”) issued by National Highways Infra Trust (NHIT) for Engagement of Agency/Firm for Providing Incident Management Vehicles at Project sites under SPVs of NHIT.

We undertake that:

1. Validity of Proposal:

The proposal submitted by us shall remain valid for a period of at least 120 (one hundred and twenty) days from the last date for submission of the proposal as specified in the RFP.

2. Fees and Charges:

No additional fees, costs, expenses, taxes, or levies shall be payable by NHIT Eastern Projects Private Limited (NEPPL) or any entities under the NHIT Eastern Projects Private Limited (NEPPL) for the services rendered, except as explicitly mentioned in the Financial Proposal.

3. Non-Blacklisting/Debarment:

We certify that we have not been banned, blacklisted, delisted, disqualified, or debarred by **NHIT**, **NHIT**, SPVs under **NHIT**, or any government agency, quasi-government agency, or PSU from participating in tenders or contracts. Additionally, no investigation is pending against us, our Managing Director (MD), Chief Executive Officer (CEO), or Directors, nor has any action been initiated against us/our Directors by the CVC, RBI, or any other government/statutory agency concerning financial irregularities.

4. Conflict of Interest:

We declare that we do not have any conflict of interest that may prejudice the scope of work under this RFP. We further confirm that we will not engage in any business or professional activities during the engagement period that may adversely affect the interests of **NHIT**, **NHIT**, or SPVs under **NHIT**.

5. Adequate Resources and Capability:

We confirm that we possess the necessary infrastructure, personnel, equipment, and resources (whether technical, financial, or operational) to perform the services or works as per the scope outlined in the RFP. We affirm that we have fully understood the scope of work and shall comply with the terms of engagement. This includes fulfilling requirements related to consultancy, civil works, road maintenance, or supply-related services, as applicable.

6. Bankruptcy/Litigation:

We certify that no bankruptcy, liquidation, or similar proceedings have been initiated against us by any entity, government agency, quasi-government agency, or PSU. Furthermore, there are no

National Highways Infra Trust

	RFP for Providing Incident Management Vehicles	Doc No.: NHIT/FY25-26/RFP/ Incident Management-02
---	---	--

material cases or proceedings pending against us or our Directors that may affect our ability to execute the contract or significantly impact our deliverables under this RFP.

7. **Accuracy of Information:**

All information provided in our Bid is true, correct, and complete to the best of our knowledge. This includes details regarding our capabilities, resources, and any other information relevant to the execution of the services or works for which the bid is submitted.

Acceptance of Terms:

We accept all the terms and conditions as mentioned in the RFP. In the event of any contradiction between the terms and conditions outlined in the RFP and our proposal/offer, the decision of **NHIT** shall prevail.

Signature(s) and Name(s) of the Authorized Signatory with Seal

Date:

National Highways Infra Trust

 National Highways Infra Trust	RFP for Providing Incident Management Vehicles	Doc No.: NHIT/FY25-26/RFP/ Incident Management-02
--	---	--

15 NON-DISCLOSURE AGREEMENT

NON-DISCLOSURE AGREEMENT

(Specimen)

This confidentiality and non-disclosure agreement (“Agreement”) is made on [●], 2026 (“Effective Date”) between National Highways Infra Investment Managers Private Limited, a company incorporated under the Companies Act, 2013, and having its registered office at G 5 & 6, Sector 10, Dwarka, New Delhi, 110075, acting on behalf of the National Highways Infra Trust (“NHIT”) and entities under **NHIT** AND [●] [Note: Name of the recipient to be included], a [company/entity/body] [incorporated/constituted] under the provisions of the laws of India, with its office at [●] [Note: To be included by the recipient] (“Recipient”). In consideration of the premises and of the mutual promises of each party to the other herein contained, it is hereby mutually agreed as follows:

WHEREAS:

- A. National Highways Authority of India (NHA) is responsible for development and maintenance of sections of national highways in India, which are entrusted to it by the Ministry of Road Transport and Highways.
- B. NHA has settled the National Highways Infra Trust (“Trust”) as a contributory irrevocable trust, in accordance with the provisions of the Indian Trusts Act, 1882.
- C. **NHIIMPL** has been appointed as the investment manager to the Trust and is responsible for, among other things, the management and administration of the Trust, and rendering investment management services to the Trust.
- D. The Trust is contemplating to mobilize funds by way of either debt raise or offer of units (“Transaction”).
- E. The Recipient is a company/entity engaged in works contracts, services, consultancy, manpower supply, or road maintenance works, as applicable, and is contemplating entering into a business relationship with **NHIT** or its entities.
- F. In order to explore a potential business relationship that might entail the Recipient receiving confidential information related to works contracts, services, consultancy, manpower supply, road maintenance, or other projects undertaken by **NHIT**, the Recipient acknowledges the sensitive nature of the Confidential Information and agrees that all Confidential Information received by it from **NHIT**/entities under **NHIT** shall be kept confidential and governed by the following terms and conditions;

I. DEFINITIONS

Term	Definition
“Discloser”	means the party providing Confidential Information for the Permitted Purpose, including, without limitation, the National Highways Infra Trust (NHIT), its associated entities, or the National Highways Infra Investment Managers Private Limited (NHIT) acting in its capacity as the manager on behalf of the Trust.
“Permitted Purpose”	means the engagement of the Recipient in works contracts, services, consultancy, manpower supply, road maintenance works, or any other related activities undertaken as part of any ongoing or

National Highways Infra Trust

 <p>NHIT National Highways Infra Trust</p>	RFP for Providing Incident Management Vehicles	Doc No.: NHIT/FY25-26/RFP/ Incident Management-02
---	---	---

Term	Definition
“Confidential Information”	<p>future projects involving the NHIT Eastern Projects Private Limited (NEPPL) or its associated entities.</p> <p>means all information, data, and ideas, whether in tangible or intangible form, disclosed by the National Highways Infra Investment Managers Private Limited (NHIIMPL) in connection with the Trust, the proposed Transaction, or its business and operations, including but not limited to:</p> <ul style="list-style-type: none"> (a) any commercial, technical, operational, or other information, data, or interpretations provided for the Permitted Purpose, expressly identified as “Confidential” in writing; (b) information relating to costs, profits, markets, sales, and financial performance; (c) plans for future developments, road construction or maintenance strategies, engineering designs, and specifications; and (d) all documents, records, designs, models, sketches, electronic data, and other materials of any nature supplied by NHIT to the Recipient.

II. CONFIDENTIALITY OBLIGATIONS

- a) **Restricted Use:** The Recipient shall use the Confidential Information solely for the Permitted Purpose and for no other purpose whatsoever.
- b) **Controlled Disclosure:** The Recipient may disclose the Confidential Information only to its employees, contractors, consultants, or advisors who require access on a strict need-to-know basis for the Permitted Purpose. Each such individual shall be informed of the confidential nature of the information and the terms of this Agreement and shall be bound by equivalent confidentiality obligations to the extent relevant and applicable.
- c) **Protection from Unauthorized Access:** The Recipient shall ensure that the Confidential Information is not disseminated to or accessible by any third party without proper authorization and shall implement appropriate security measures to safeguard the Confidential Information, consistent with its own protocols for managing proprietary and confidential information.
- d) **Legal and Regulatory Compliance:** The Recipient shall comply with all applicable laws, including but not limited to laws governing trade secrets, data privacy, and securities regulations, such as the Securities and Exchange Board of India (Prohibition of Insider Trading) Regulations, 2015, as amended.
- e) **Restrictions on Trading and Transactions:** For a period of six months from the date of return of the Confidential Information or termination of this Agreement, or for a period of ninety (90) days from the date of completion of the Transaction, whichever is later, the Recipient shall not, directly or indirectly, trade, acquire, or sell, or agree, propose, seek, or offer to acquire or sell, or facilitate the acquisition, ownership, or sale of any securities or business (or any part thereof) of the Discloser, including the Trust.

III. EXCEPTIONS

The obligations under **Clause No. II** shall not apply to any Confidential Information that:

- a) **Prior Possession:** Was in the lawful possession of the Recipient prior to its disclosure by the Discloser and without any restriction on its use or disclosure;

National Highways Infra Trust

	RFP for Providing Incident Management Vehicles	Doc No.: NHIT/FY25-26/RFP/ Incident Management-02
---	---	--

- b) **Independent Development:** Was independently developed by the Recipient without reference to or use of the Confidential Information;
- c) **Public Domain:** Was in the public domain at the time of disclosure under this Agreement or subsequently becomes publicly available, except as a result of a breach of this Agreement by the Recipient;
- d) **Third-Party Disclosure:** Is disclosed to the Recipient by a third party who, to the best of the Recipient's knowledge, is not bound by any confidentiality obligation to the Discloser;
- e) **Authorized Disclosure:** Is expressly authorized for release by the Discloser in writing;
- f) **Mandatory Disclosure:** Is required to be disclosed under applicable law or regulation, or by an order of a governmental, judicial, or quasi-judicial authority, or:
 - i) Is disclosed to the Recipient's lenders or insurers in connection with any loan or insurance arrangement, provided that the Recipient:
 - Notifies the Discloser in writing, to the extent permissible under law, to allow the Discloser to contest or seek protective measures against such disclosure; and
 - Limits such disclosure strictly to the extent required under the circumstances.

IV. NO GRANT OF PROPRIETARY RIGHTS OR LICENSE

The Confidential Information shall remain the exclusive property of the Discloser at all times. Nothing in this Agreement shall be construed as granting, by implication, estoppel, or otherwise, any license, right, title, or interest in or to the Confidential Information to the Recipient for any purpose. The Discloser retains all proprietary rights in and to the Confidential Information, including but not limited to any intellectual property rights, and the Recipient acknowledges that it acquires no such rights through the disclosure of Confidential Information under this Agreement.

V. TERM AND TERMINATION

This Agreement, along with the Confidentiality Obligations contained herein, shall come into force on the date of issuance of the Letter of Engagement or Letter of Appointment and shall remain effective until the completion of the specified term or as otherwise agreed in writing. Notwithstanding the foregoing, the Discloser reserves the right to terminate this Agreement at any time by providing written notice to the Recipient. Termination shall not affect the Recipient's continuing obligations with respect to the protection and non-disclosure of Confidential Information, which shall survive termination for a period of [insert specific period, e.g., two years], or as required by applicable law.

VI. INJUNCTION

The Parties acknowledge and agree that the Confidential Information is valuable, unique, and integral to the interests of the Discloser. Any unauthorized use, disclosure, or breach of the Confidentiality Obligations by the Recipient may cause irreparable harm to the Discloser for which monetary damages may be inadequate. Accordingly, the Discloser shall be entitled to seek injunctive relief, including temporary, preliminary, or permanent injunctions, from a competent court to prevent or restrain any such breach or threatened breach. Such relief shall be in addition to, and not in substitution for, any other legal or equitable remedies available, including claims for monetary damages.

VII. RETURN OF MATERIALS

National Highways Infra Trust

	RFP for Providing Incident Management Vehicles	Doc No.: NHIT/FY25-26/RFP/ Incident Management-02
---	---	--

Upon the Discloser's written request, the Recipient shall promptly, and in any event within five (5) days or such later period as specified by the Discloser, return all copies of the Confidential Information in any form or medium, or, if so, directed by the Discloser, destroy such copies. Any destruction shall be carried out in such a manner that the Confidential Information cannot be retrieved or reconstructed. The Recipient shall certify in writing to the Discloser that all such Confidential Information has been returned or destroyed, as applicable, and that no copies thereof remain in the Recipient's possession.

VIII. ACKNOWLEDGEMENT

The Recipient acknowledges and agrees that:

- a) This Agreement does not, and shall not be construed to, constitute a solicitation or offer for the sale or transfer of any securities of the Discloser, or any affiliate of the Discloser, or any entity sponsored by the Discloser.
- b) This Agreement does not impose any obligation or commitment on the Discloser to issue, sell, or transfer any securities of the Discloser or any other person or entity.
- c) Any subscription or purchase of securities of the Discloser, any affiliate of the Discloser, or any entity sponsored by the Discloser by the Recipient shall be conducted in full compliance with applicable laws and regulations, and shall be solely on the basis of offer document(s) or prospectus related to such securities, which shall be prepared and issued in accordance with such applicable laws.

IX. MISCELLANEOUS:

a) No waiver by the Discloser of any breach or default by the Recipient under this Agreement shall be deemed a waiver of any subsequent or continuing breach or default thereof. This Agreement constitutes the entire understanding and agreement between the parties with respect to the subject matter hereof, and supersedes all prior negotiations, discussions, representations, and agreements, whether oral or written, relating to the same, except that nothing herein shall prejudice the statutory or common law rights of either party in relation to Confidential Information. This Agreement may only be amended or modified in writing, executed by duly authorized representatives of both parties. If any provision of this Agreement is held to be invalid, illegal, or unenforceable, the remaining provisions shall continue in full force and effect. This Agreement is executed in two (2) originals, each of which shall be deemed an original for all purposes. This Agreement shall become effective as of the date first written above, upon execution by both parties.

b) For the avoidance of doubt, the parties further agree as follows:

- (i) The terms and provisions of this Agreement are confidential.
- (ii) In the event that the parties enter into any further agreements related to the Investment Opportunity or in connection with the evaluation or facilitation of the Investment Opportunity, this Agreement shall continue to be binding on the parties with respect to any Confidential Information exchanged in such subsequent agreements.
- (iii) The recitals set forth above shall be deemed an integral part of this Agreement;
- (iv) The Recipient acknowledges that the Discloser makes no representation or warranty, express or implied, as to the accuracy or completeness of the Confidential Information or any other information provided; and

National Highways Infra Trust

 National Highways Infra Trust	RFP for Providing Incident Management Vehicles	Doc No.: NHIT/FY25-26/RFP/ Incident Management-02
--	---	--

(v) This Agreement shall be binding upon and inure to the benefit of the parties hereto, their respective successors, and permitted assigns.

X. GOVERNING LAWS

This Agreement shall be governed by, and construed in accordance with, the laws of India, without regard to its conflicts of law principles. The parties expressly agree that any dispute, controversy, or claim arising out of or in connection with this Agreement, or the breach, termination, or validity thereof, shall be subject to the exclusive jurisdiction of the courts located in New Delhi, India. The parties hereby irrevocably consent to the jurisdiction of such courts and waive any objection to the venue of such courts, including any objection based on forum non convenience or similar grounds.

Notwithstanding the above, the parties agree that either party may seek interim or urgent relief in any other competent court or tribunal, including but not limited to injunctions or orders for specific performance, without prejudice to the exclusive jurisdiction of the courts of New Delhi, India, for all other matters.

XI. SURVIVAL

Notwithstanding the termination or expiration of this Agreement, the provisions set forth in **Clause No's** II(d), VIII, and X of this Agreement shall survive in full force and effect. These **Clause No's** shall remain binding on the parties and shall continue to be enforceable to the extent necessary to give effect to the rights and obligations contained therein.

The survival of these provisions shall be governed by the nature and intent of the respective **Clause No's**, and the parties agree that any obligations, rights, or duties arising from these provisions will remain operative even after the termination or expiration of this Agreement, for such period as is necessary to complete or resolve any obligations or claims arising thereunder.

In particular, **Clause No. II (d)** (which addresses the confidentiality obligations), **Clause No. VIII** (which pertains to dispute resolution and jurisdiction), and **Clause No. X** (which addresses any post-termination rights or duties) shall remain in effect for a period, where applicable, in accordance with the applicable statutory laws or as otherwise expressly stated in this Agreement.

IN WITNESS WHEREOF, the parties hereto have caused this Agreement to be executed by their duly authorized representatives on the day and date mentioned hereinabove.

Signed and delivered by **NHIT** by the hand of

Authorised Signatory

Name:

Designation:

Signed and delivered by [•] [Note: Name of the Recipient to be inserted], by the hand of

Authorised

Name:

Designation:

Signatory

National Highways Infra Trust

 <small>National Highways Infra Trust</small>	RFP for Providing Incident Management Vehicles	Doc No.: NHIT/FY25-26/RFP/ Incident Management-02
---	---	--

16 Power of Attorney

POWER OF ATTORNEY
(Specimen)

KNOW ALL MEN BY THIS POWER OF ATTORNEY:

WHEREAS _____, a firm registered under the provisions of the P _____, having registration number _____ and having its office at _____ (hereinafter called the 'Firm').

AND WHEREAS the Firm intends to submit its bid in respect of "[●]".

WHEREAS it is considered necessary and expedient to execute a general Power of Attorney in favour of [●], [●] of the Firm, on behalf of the Firm, to authorises him to submit the bid on behalf of the Firm.

NOW THIS POWER OF ATTORNEY WITNESSES AS FOLLOWS:

The Firm hereby appoints [●], designated as [●] of the Firm, as its Attorney (hereinafter collectively called "the Attorney") to do the following acts, deeds and things in the name and on behalf of the Firm for successful submission of the bid in respect of abovementioned RFP:

1. To sign and submit technical & financial proposal, on behalf of Firm, in respect of the proposal for [●].
2. To upload the documents on e-tender portal and attach the digital signature of the Firm to document, enrol the digital signature with the e-tender portal of the, and to do any other activity.
3. To sign all applications, affidavits, agreements, amendments, clarifications and all such other documents, as may be necessary for submission of the bid for engagement of legal advisers for proposed assignment and to do all other activity as may be required for successful bid submission.
4. This authority letter shall be valid from the date of issue and shall remain in force till completion of the bidding process in accordance with the Tender Notice No: [●], as amended.

IN WITNESS WHEREOF this deed has been signed by Shri [●] of the Firm.

<p>Accepted by:</p> <p>Accepted _____ By</p>	<p>For [●]</p> <p>Granted _____ by</p>
--	--

Witness.

1. _____
2. _____

National Highways Infra Trust

	RFP for Providing Incident Management Vehicles	Doc No.: NHIT/FY25-26/RFP/ Incident Management-02
---	---	--

17 Environmental Management Plan (EMP)

A structured and detailed format for contractors to ensure comprehensive environmental protection and compliance throughout the project lifecycle.

1. Executive Summary

A snapshot of the project's objectives, key environmental measures, and expected outcomes.

- i. Overview of the project scope and objectives.
- ii. Key environmental measures and anticipated outcomes.
- iii. Highlights of the contractor's commitment to sustainability.

2. Introduction

This section outlines the EMP's purpose, project scope, and applicable environmental regulations.

- i. Purpose and objectives of the EMP.
- ii. Project description, including location, scale, and scope of work.
- iii. Applicable environmental regulations, guidelines, and standards.

3. Environmental Baseline Conditions

Provides a summary of the current environmental features and potential risks identified before construction.

- i. Summary of pre-construction environmental surveys and studies.
- ii. Description of environmental features:
 - o Sensitive areas (e.g., water bodies, wetlands).
 - o Flora and fauna, including endangered species.
 - o Soil, water, and air quality conditions.
- iii. Identification of key environmental risks.

4. Environmental Management Objectives

Defines the overarching and specific goals for safeguarding the environment throughout the project.

- i. Overall goals for environmental protection.
- ii. Specific objectives:
 - o Pollution prevention.
 - o Biodiversity conservation.
 - o Efficient resource use and waste minimization.

5. Roles and Responsibilities

Clearly delineates the roles of the contractor, Environmental Officer, and other stakeholders in implementing the EMP.

- i. Defined responsibilities of:
 - o Contractor and subcontractors.
 - o Environmental Officer or Site Supervisor.
- ii. Coordination protocols with local authorities, stakeholders, and regulatory agencies.

National Highways Infra Trust

 <p>NHIT National Highways Infra Trust</p>	<p>RFP for Providing Incident Management Vehicles</p>	<p>Doc No.: NHIT/FY25-26/RFP/ Incident Management-02</p>
---	--	---

6. Environmental Impact Assessment (EIA)

Summarizes identified environmental impacts, including their short-term and long-term implications.

- i. Summary of the environmental impact study.
- ii. Identification of:
 - o Short-term and long-term impacts.
 - o Cumulative impacts and mitigation hierarchy.

7. Mitigation Measures

Lists detailed actions to minimize negative environmental impacts, categorized by type.

- i. Category-wise measures to mitigate impacts:
 - a) **Air Quality:** Dust suppression, vehicle emission controls.
 - b) **Water Quality:** Sedimentation control, preventing contamination.
 - c) **Soil Conservation:** Erosion prevention, topsoil preservation.
 - d) **Waste Management:** Segregation, recycling, safe disposal.
 - e) **Noise Management:** Noise barriers, equipment soundproofing.
 - f) **Biodiversity:** Protection of species and habitats.

8. Pollution Control Plan

Specific measures to prevent and control air, water, and noise pollution during the project.

- i. Measures to address air, water, and noise pollution.
- ii. Use of eco-friendly machinery and construction practices.
- iii. Spill containment and response procedures.

9. Waste Management Plan

Details procedures for handling, storing, and disposing of hazardous and non-hazardous waste.

- i. Waste categorization (hazardous, non-hazardous, recyclable).
- ii. Methods for collection, storage, transport, and disposal.
- iii. Procedures for compliance with local waste regulations.

10. Monitoring Plan

Outlines the parameters, frequency, and methodology for monitoring environmental compliance.

- i. Parameters for monitoring (e.g., air, water, and noise quality).
- ii. Monitoring frequency, tools, and techniques.
- iii. Reporting mechanism and corrective actions for deviations.

11. Emergency Preparedness and Response

Describes the procedures and training to handle environmental emergencies effectively.

- i. Response plan for environmental emergencies (e.g., spills, leaks).

National Highways Infra Trust

	RFP for Providing Incident Management Vehicles	Doc No.: NHIT/FY25-26/RFP/ Incident Management-02
---	---	--

- ii. Emergency contact list for stakeholders and authorities.
- iii. Staff training for emergency handling and response readiness.

12. Training and Awareness

Explains plans for workforce training and awareness programs on environmental practices.

- i. Training schedules for workforce on EMP requirements.
- ii. Awareness programs for:
 - a) Pollution prevention.
 - b) Efficient resource use.
 - c) Incident reporting and management.

13. Reporting and Documentation

Defines the format and frequency for compliance reports and record-keeping requirements.

- i. Reporting schedule and formats (daily, weekly, monthly).
- ii. Documentation requirements for:
 - a) Monitoring results.
 - b) Waste handling and disposal records.
 - c) Incident logs.

14. Budget and Resource Allocation

Provides an estimate of financial and resource requirements for EMP implementation.

- i. Detailed budget for implementing the EMP.
- ii. Resource allocation for environmental equipment, training, and compliance activities.

15. Appendices

Contains supporting documents such as maps, permits, and contact lists for stakeholders.

- i. Maps of sensitive ecological areas and project layout.
- ii. Permits, approvals, and regulatory compliance documentation.
- iii. Contact details of stakeholders, authorities, and emergency response personnel.

18 List of Annexures

Annexure no.	Section No.	Clause No. No.	Annexure details
Contract Conditions			
Annexure-A1	Section 5	5.1	General Conditions of Contract (GCC) covering rights, obligations, payment terms, and dispute resolution.
Annexure-A2	Section 5	5.2	Special Conditions of Contract (SCC) outlining project-specific terms and conditions.

National Highways Infra Trust

 National Highways Infra Trust	RFP for Providing Incident Management Vehicles	Doc No.: NHIT/FY25-26/RFP/ Incident Management-02
--	---	--

Annexure no.	Section No.	Clause No. No.	Annexure details
Annexure-A3	Section 11	11.2	List of Approved Makes
Standard HSE & Safety Compliance			
Annexure-A4	Section 6	6.5	Utility shifting guidelines for safety, compliance, and timely execution.
Annexure-A5	Section 8	8	NHIT's EHS Policy
Standard Formats			
Annexure-B1	Section 2	2.3.2	Bank Guarantee Template for Bid Security
Annexure-B2	Section 10	10.1	Performance Security Template
Annexure-B3	Section 10	10.2	Bank Guarantee Template
Project-Specific Annexures			
Annexure-C1	Section 5	5.3	Contract Data Sheet detailing project-specific information like milestones, equipment, and safety guidelines.
Annexure-C2	Section 4	4.2.1	Scope of Work
Annexure-C3	Section 9	9.3	Bill of Quantities
Annexure-C4	Section 4	4.2.4	Detailed location maps, site layouts, and access points are provided in the Annexure for the Bidder's reference.
Annexure-C5	Section 6	6.1	Design requirements including parameters for structural and safety submissions.
Annexure-C6	Section 6	6.2	Construction requirements covering quality, workmanship, and testing standards.
Annexure-C7	Section 6	6.3	Technical specifications based on MoRTH, IRC, and IS codes.
Annexure-C8	Section 6	6.4	Approved drawings including layouts, GADs, and structural details.
Annexure-C9	Section 11	11.1	Draft Contract Agreement
Annexure-C10			Process of Online Bid Submission

Annexure A1

General Conditions of Contract

National Highways Infra Trust

 <small>National Highways Infra Trust</small>	General Conditions of Contract	Doc No.: NHIT/FY25-26/RFP/ Incident Management
---	---------------------------------------	--

Contents

Purpose of this General Conditions of Contract	8
1. Definitions and Interpretations	8
2. Scope of Work	15
2.1 General Scope.....	15
2.2 Detailed Scope of Works / Services	15
2.3 Contractor’s Obligations.....	16
2.4 Coordination and Reporting.....	16
2.5 Exclusions	16
3. Contract Period and Validity	17
3.1 Contract Period	17
3.2 Extension of Contract Period	17
3.3 Validity of Contract.....	17
3.4 Survival of Obligations After Termination.....	17
3.5 Termination and Final Acceptance	17
4. Contractor’s Obligations	17
4.1 General Obligations	17
4.2 Obligations Relating to Performance and Quality.....	18
4.3 Staffing and Resource Management.....	18
4.4 Health, Safety, and Environmental Requirements.....	18
4.5 Insurance Obligations.....	18
4.6 Site Management and Supervision.....	18
4.7 Subcontracting.....	18
4.8 Compliance with Laws and Regulations	18
4.9 Indemnity and Liability	18
4.10 Reporting and Documentation.....	18
4.11 Maintenance and Performance Standards	18
4.12 Dispute Resolution.....	18
4.13 Termination of Contract.....	18
4.14 The duties of the contractor	18
5. Contractor’s Personnel	19
5.1 Contractor’s Responsibility:.....	19
5.2 Key Personnel:.....	19
5.3 Substitution of Personnel:	19
5.4 Non-Compliance and Disciplinary Action:	19
5.5 Health, Safety, and Welfare:	19
5.6 Workforce Composition:.....	19
5.7 Contractor’s Supervision:.....	19
5.8 Employee Welfare and Benefits:	19
5.9 Exclusivity of Personnel:.....	19
5.10 Compliance with Local Regulations:.....	20
6. Subcontracting and Assignment.....	20
6.1 Subcontracting Approval:	20
6.2 Contractor’s Responsibility:.....	20
6.3 Assignment and Transfer:	20
6.4 Subcontractor Compliance:	20
6.5 Notification of Changes:.....	20
6.6 Subcontractor’s Documentation:.....	20

National Highways Infra Trust

 <small>National Highways Infra Trust</small>	General Conditions of Contract	Doc No.: NHIT/FY25-26/RFP/ Incident Management
---	---------------------------------------	--

6.7	Insurance Requirements:.....	20
6.8	Subcontractor Performance:.....	20
6.9	Indemnity:	20
7.	Risk Allocation	20
7.1	Client’s Risks:	20
7.2	Contractor’s Risks:	21
7.3	Shared Risks:.....	21
7.4	Risk Cost Purchase (Client’s Risk Mitigation Effort):.....	21
7.5	Risk Mitigation and Notification:	21
7.6	Force Majeure:.....	21
7.7	Insurance for Risk Management:.....	21
8.	Quality Control and Assurance	22
8.1	General Obligations	22
8.2	Quality Assurance Plan (QAP)	22
8.3	On-Site Testing Laboratory	22
8.4	Material Source Approval.....	22
8.5	Inspection and Testing Protocols.....	22
8.6	Non-Conformance Management	22
8.7	Defects Rectification and Timelines.....	23
8.8	Documentation and Reporting.....	23
8.9	Continuous Improvement Measures.....	23
8.10	Penalties for Quality Non-Compliance.....	23
9.	Work Execution and Methodology	23
9.1	General Obligations	23
9.2	Road Construction Methodology	24
9.3	Bridge and Structural Construction Methodology.....	24
9.4	Periodic Maintenance Methodology	25
9.5	Periodic Maintenance of Bridges and Structures.....	26
9.6	Detailed Maintenance Methodology	27
9.7	Routine Maintenance Execution.....	27
9.8	Emergency Repairs Under Routine Maintenance.....	27
9.9	Approval Process for Deviations	28
9.10	Material Selection and Handling	28
9.11	Timely Execution and Scheduling	28
9.12	Site Mobilization and Readiness.....	28
9.13	Quality Control during Execution	28
9.14	Health, Safety, and Environmental Considerations.....	29
9.15	Traffic Management and Public Communication.....	29
9.16	Inspection and Supervision.....	29
9.17	Non-Conformance and Corrective Action	30
9.18	Reporting and Documentation	30
9.19	Completion and Handover.....	30
10.	Materials and Equipment	30
10.1	General Requirements.....	30
10.2	Materials.....	30
10.3	Equipment for Execution and Maintenance.....	31
10.4	Quality Assurance and Testing of Materials	31
10.5	Storage and Handling of Materials and Equipment.....	32

National Highways Infra Trust

 <small>National Highways Infra Trust</small>	General Conditions of Contract	Doc No.: NHIT/FY25-26/RFP/ Incident Management
---	---------------------------------------	--

10.6	Non-Conformance of Materials and Equipment.....	32
10.7	Client’s Rights to Inspect and Test.....	33
10.8	Documentation and Reporting	33
11.	Health, Safety, and Environmental Requirements	33
11.1	Compliance	33
12.	Insurance and Liability.....	33
12.1	Contractor’s Insurance Requirements.....	33
12.2	Workmen’s Compensation Insurance.....	33
12.3	Contractor All Risk (CAR) Insurance.....	33
12.4	Other Insurances	33
12.5	Proof of Insurance.....	34
12.6	Failure to Insure	34
12.7	Indemnity	34
12.8	Insurance Documentation and Proof.....	34
12.9	Additional Insurances	34
12.10	Liabilities and Limitations	34
12.11	Specific Insurance for Road Maintenance Works	34
13.	Labor Laws and Statutory Compliance.....	35
13.1	General Compliance	35
13.2	Wage Payment and Benefits.....	35
13.3	Labor Licenses and Registrations.....	35
13.4	Health, Safety, and Welfare	35
13.5	Prohibition of Child and Forced Labor.....	35
13.6	Compliance Monitoring and Reporting	35
13.7	Labor Disputes and Resolution	35
13.8	Indemnification	35
13.9	Penalty for Non-Compliance	35
13.10	Specific to Road Maintenance.....	36
14.	Payment Terms and Conditions	36
14.1	General.....	36
14.2	Payment on Percentage Basis	36
14.3	Lump-Sum Payment.....	36
14.4	BoQ-Based Item Rate Payment	36
14.5	Retention Money	36
14.6	Advance Payments	36
14.7	Payment Certification and Conditions.....	36
14.8	Taxes and Deductions	37
14.9	Final Bill Settlement.....	37
14.10	Interim Payment Method and Requirements.....	37
14.11	Submission of Documentation Along with Invoice	37
15.	Performance Standards and Penalties.....	38
15.1	Performance Standards	38
15.2	Minimum Performance Requirements.....	38
15.3	Monitoring and Inspection.....	39
15.4	Penalties for Non-Compliance	39
15.5	Grace Period for Rectification	40
15.6	Cumulative Penalties and Termination	40
15.7	Documentation of Penalties and Appeals	40

National Highways Infra Trust

 <small>National Highways Infra Trust</small>	General Conditions of Contract	Doc No.: NHIT/FY25-26/RFP/ Incident Management
---	---------------------------------------	--

16. Amendments and Variations	40
16.1 Change Management Framework.....	40
16.2 Definition of Amendments and Variations.....	41
16.3 Initiation of Variations.....	41
16.4 Process for Issuing a Variation or Amendment.....	41
16.5 Cost and Payment for Variations.....	43
16.6 Time Implications of Variations.....	43
16.7 Variation Documentation and Records.....	43
16.8 Dispute Resolution for Variations	43
17. Governing Law and Jurisdiction.....	44
18. Dispute Resolution	44
18.1 Dispute Notification and Procedure	44
18.2 Amicable Settlement.....	44
18.3 Dispute Resolution Board (DRB).....	44
18.4 Arbitration	44
18.5 Jurisdiction and Venue	45
18.6 Interim Relief.....	45
18.7 No Suspension of Work.....	45
19. Force Majeure	45
19.1 Definition	45
19.2 Consequences of Force Majeure.....	45
19.3 Exclusions	46
19.4 Extension of Time.....	46
19.5 Payments During Force Majeure.....	46
19.6 Final Determination	46
20. Termination of Contract	46
20.1 Termination by the Client	46
20.2 Termination by the Contractor	47
20.3 Procedure for Termination.....	47
20.4 Post-Termination Obligations	47
20.5 Liabilities Upon Termination.....	47
20.6 Survival of Provisions	48
20.7 Dispute Arising from Termination	48
21. Extension of Time	48
21.1 Request for Extension:.....	48
21.2 Time Extension Request Procedure:.....	48
21.3 Approval and Grant of Extension:.....	48
21.4 No Financial Compensation:	49
21.5 Liquidated Damages during Extension:.....	49
21.6 Client's Right to Terminate for Prolonged Delay:.....	49
22. Price Variation / Escalation	49
22.1 Scope of Price Variation	49
22.2 Escalation Calculation Formula	49
22.3 Escalation Components and Basis	49
22.4 Calculation of Price Variation	51
22.5 Invoice Value for Price Variation	51
22.6 Exclusions for Price Variation.....	52
22.7 Component Weightage.....	52

National Highways Infra Trust

 <small>National Highways Infra Trust</small>	General Conditions of Contract	Doc No.: NHIT/FY25-26/RFP/ Incident Management
---	---------------------------------------	--

22.8	Limitations on Price Variation	52
22.9	Final Adjustment.....	52
23.	Substantial Completion and Final Acceptance	52
23.1	Substantial Completion.....	52
23.2	Final Acceptance	53
23.3	Retention of Rights	54
23.4	Disputes Regarding Acceptance	54
23.5	Consequences of Non-Compliance.....	54
24.	Warranty and Maintenance Period	54
24.1	Warranty Period:.....	54
24.2	Maintenance Period	55
24.3	Defect Rectifications During Warranty and Maintenance Period.....	55
25.	Site Management and Supervision	57
25.1	Site Management and Supervision Requirements:.....	57
25.2	Qualification of Engineers and Personnel:.....	57
25.3	Organization Chart and Manpower Deployment:.....	57
25.4	Construction Schedule and Work Monitoring:.....	57
25.5	Progress Reporting and Documentation:	57
25.6	Supervision and Site Inspections:.....	58
25.7	Coordination and Collaboration:	58
25.8	Site Safety and Compliance:.....	58
25.9	Penalties for Non-Compliance:	58
26.	Indemnity and Liability	58
26.1	Contractor’s Liability for Faults and Failures:.....	58
26.2	Recovery of Costs:	59
26.3	Indemnity:	59
26.4	Exclusion of Certain Liabilities:.....	59
26.5	Documentation and Notices:.....	59
27.	Reporting and Documentation.....	59
27.1	General Reporting Requirements:.....	59
27.2	Types of Reports:	60
27.3	Document Submission Requirements:	60
27.4	Documentation for Payment Claims:.....	61
27.5	Record Keeping and Client Access:.....	62
27.6	Corrective Actions for Non-Compliance:.....	62
27.7	Final Documentation:	62
27.8	Electronic Submission of Documents:.....	62
28.	Maintenance Responsibilities and Post-Completion Obligations.....	63
28.1	Contractor’s Obligations for Maintenance Works.....	63
28.2	Inspection, Monitoring, and Reporting	63
28.3	Defect Rectification and Performance Assurance	63
28.4	Post-Completion Monitoring and Extended Responsibility	64
28.5	Documentation and Record-Keeping	64
29.	Defects Liability Period (DLP)	64
29.1	Definition and Scope.....	64
29.2	Rectification of Defects	65
29.3	Inspection During DLP.....	65
29.4	Maintenance During DLP	65

National Highways Infra Trust

 <small>National Highways Infra Trust</small>	General Conditions of Contract	Doc No.: NHIT/FY25-26/RFP/ Incident Management
---	---------------------------------------	--

29.5	Final Inspection and Handover	65
29.6	Extension of DLP	66
29.7	Retention Release	66
29.8	Duration of DLP	66
30.	Liquidated Damages	66
30.1	Applicability	66
30.2	Trigger for Liquidated Damages	67
30.3	Rate of Liquidated Damages	67
30.4	Computation and Deduction.....	67
30.5	Exemptions	67
30.6	Additional Penalties for Chronic Non-Performance	67
30.7	Non-Exclusivity of LD	67
30.8	Acknowledgement.....	67
31.	Notices and Communications.....	67
31.1	Mode of Communication:.....	67
31.2	Designated Contact Details:.....	68
31.3	Effective Date of Notices:.....	68
31.4	Change of Address or Contact Details:.....	68
31.5	Language of Communication:.....	68
31.6	Binding Nature of Communications:.....	68
31.7	Service of Legal Notices:.....	68
32.	Confidentiality and Non-Disclosure	68
32.1	Confidential Information:.....	68
32.2	Obligations of the Contractor:.....	68
32.3	Permitted Disclosures:	68
32.4	Exclusions from Confidentiality:.....	68
32.5	Return or Destruction of Information:	69
32.6	Duration of Confidentiality Obligations:.....	69
32.7	Remedies for Breach:.....	69
33.	Bank Guarantee Formats	69
33.1	Bank Guarantee Formats:.....	69
33.2	Availability of Formats:	69
33.3	Compliance with Format:	69
33.4	Submission of Bank Guarantees:.....	69
33.5	Costs of Bank Guarantees:	70
34.	Limitation of Liability	70
35.	Annexures and Appendices	70
36.	Other Conditions	71
36.1	General Compliance	71
36.2	Interpretation of Contract.....	71
36.3	Confidentiality and Intellectual Property Rights	71
36.4	Third-Party Rights	72
36.5	Force of Documentation	72
36.6	Provisions for Emergencies.....	72
36.7	Waiver.....	72
36.8	Entirety of Agreement	73
36.9	Survival of Terms	73
36.10	Acknowledgment.....	73

National Highways Infra Trust

	General Conditions of Contract	Doc No.: NHIT/FY25-26/RFP/ Incident Management
---	---------------------------------------	--

36.11 Language of the Contract73

National Highways Infra Trust

	General Conditions of Contract	Doc No.: NHIT/FY25-26/RFP/ Incident Management
---	---------------------------------------	--

Purpose of this General Conditions of Contract

The purpose of this General Conditions of Contract (GCC) is to provide a structured and comprehensive framework governing the rights, obligations, and responsibilities of the Employer and the Contractor in executing road maintenance works. This GCC establishes clear guidelines to ensure compliance with applicable standards, including **MoRTH specifications, IRC guidelines**, and relevant statutory requirements. It addresses key aspects such as the scope of work, performance standards, risk allocation, payment terms, and dispute resolution, while mandating adherence to safety, environmental, and quality control measures. Additionally, this GCC incorporates provisions for insurance, indemnities, and warranties to safeguard both parties and maintain infrastructure quality. By aligning with **Best Practices for Contractual Governance**, the GCC ensures transparency, efficiency, and accountability in managing the contract, fostering collaboration to achieve the timely and effective maintenance of road infrastructure.

1. Definitions and Interpretations

For the purpose of this Agreement, the following terms shall have the meanings ascribed to them, unless the context clearly requires otherwise. These definitions are provided to ensure a clear and consistent interpretation of the terms used throughout the Agreement.

Term	Definition
Acceptance	Shall mean the formal acknowledgment by the Client, upon verification that the works have been completed in accordance with the agreed scope, specifications, and standards prescribed under the Contract, including compliance with MoRTH, IRC, IS Codes, and other applicable regulations.
Alternative Dispute Resolution (ADR)	Shall mean a mechanism for resolving disputes between the parties, including but not limited to mediation, conciliation, or arbitration, as an alternative to formal litigation. The procedures for ADR shall be governed as per the provisions outlined under the Dispute Resolution Clause 18 of this GCC.
Alternative Works	Shall mean any works or services undertaken to replace, modify, or supplement the original scope of works due to unforeseen circumstances, changes in site conditions, or as directed by the Client, ensuring compliance with the Contract's terms and specifications.
Annual Performance Review	Shall mean the periodic evaluation conducted by the Client to assess the Contractor's performance in accordance with the terms, obligations, and key performance indicators stipulated in the Contract Agreement during its term.
Arbitration	Shall mean the process by which a dispute arising under the contract is resolved by an independent third-party arbitrator, whose decision is final and binding on the parties, in accordance with the provisions of the <i>Arbitration and Conciliation Act, 1996</i> (as amended), and as outlined in Clause 18 of this GCC.
Agreement	Shall mean the legally binding contract executed between the Client and the Contractor for providing services related to road construction and maintenance projects. It includes the General Conditions of Contract (GCC), Special Conditions of Contract (SCC), Annexures, Letter of Award (LoA), schedules, and any mutually agreed amendments or modifications. The Agreement defines the roles, responsibilities, deliverables, timelines, and performance standards expected of the Contractor and governs the

National Highways Infra Trust

	General Conditions of Contract	Doc No.: NHIT/FY25-26/RFP/ Incident Management
---	---------------------------------------	--

Term	Definition
	contractual relationship between the parties in accordance with applicable laws, regulations, and standards, including those specified by the Ministry of Road Transport and Highways (MoRTH) and other relevant authorities.
Bank Guarantee	Shall mean a written guarantee issued by a bank, on behalf of the Contractor, to secure the performance or payment obligations under the contract, ensuring that the bank will fulfil the financial commitments in the event of the Contractor's failure to perform as per the terms and conditions of the contract.
Base Date	Shall mean the date up to which the conditions of the site, works, and environment are considered for the purpose of contract price adjustments.
Bid Price	Shall mean the total price submitted by the Contractor in response to the Client's invitation for tenders, which encompasses all costs, including labor, materials, equipment, overheads, and other expenses necessary for the completion of the works in accordance with the contract requirements.
Bill of Quantities (BoQ)	Shall mean a document prepared by the Client or their representative, detailing the quantities and specifications of all works to be executed under the contract. It serves as a basis for pricing and tender evaluation, including the measurement of work items, their unit rates, and estimated costs to aid in the preparation of the Contractor's bid. The BoQ forms an integral part of the contract and is used for determining the contract value and assessing any variations in the work.
Boundary Line	Shall mean the line demarcating the boundary of the site or the area of the concession.
Bridge	Shall mean a structure designed and constructed to carry traffic or other loads across a watercourse, depression, road, or other physical obstacle. It typically consists of a deck supported by substructures, such as piers, abutments, or foundations, and is intended to facilitate safe and efficient passage of vehicles, pedestrians, and other loads in accordance with relevant design standards and specifications.
Certificate of Completion	Shall mean a formal certificate issued by the Engineer to the Contractor upon the satisfactory completion of the works, confirming that the works have been completed in accordance with the contract documents, specifications, and other applicable requirements. The certificate signifies that the works have met the required standards and are deemed ready for handover to the Client, subject to any outstanding issues or defects identified during the final inspection.
Claim	Shall mean a formal written request by the Contractor for an adjustment to the contract terms, including but not limited to changes in time, cost, or scope, arising from unforeseen circumstances, variations, or other causes beyond the Contractor's control that affect the performance of the contract.
Client / Employer	Shall refer to NHIT and its subsidiaries, incorporated under the Companies Act, along with their legal successors, assignees, and authorized officers, who are entitled to the rights and remedies as outlined in the Contract.
Commencement Date	Shall mean the date specified in the contract from which the Contractor is required to begin the execution of the works.

National Highways Infra Trust

	General Conditions of Contract	Doc No.: NHIT/FY25-26/RFP/ Incident Management
---	---------------------------------------	--

Term	Definition
Compensation Event	Shall mean an event or circumstance as defined in the contract that entitles the Contractor to claim an extension of time or additional payment for costs incurred due to the occurrence of such event, which was beyond the Contractor's control and not attributable to the Contractor's actions or omissions.
Completion Date	Shall mean the date by which the Contractor is required to complete the works, as agreed in the contract.
Completion Certificate	Shall mean the certificate issued by the Client or Engineer confirming that the works have been completed in accordance with the contract specifications, and all requirements have been met to the satisfaction of the Client or Engineer.
Confidential Information	<p>Shall mean any data or information, whether written, oral, or in any other form, relating to the works, the contract, or any other aspect of the project, which is confidential in nature and is not to be disclosed to third parties without the prior written consent of the disclosing party. This shall include, but not be limited to, business plans, technical data, financial information, and proprietary information.</p> <p>The disclosure and protection of Confidential Information may also be governed by applicable laws, including the Indian Contract Act, 1872 and the Information Technology Act, 2000, along with any confidentiality or non-disclosure agreements between the parties.</p>
Contract Price	Shall mean the total amount agreed upon between the Client and the Contractor for the execution of the works, as specified in the contract, including any adjustments made due to changes, variations, or modifications in the scope of work, in accordance with the terms and conditions of the contract. This may include taxes, duties, and other financial obligations as specified under the contract.
Contractor	Shall mean the individual, firm, or company engaged by the Client to execute the works as per the terms and conditions of the contract, including any subcontractors or agents employed by the Contractor for the performance of the works.
Contractor's Equipment	Shall mean all equipment, machinery, tools, vehicles, and other resources provided by the Contractor to execute the works, including any temporary or permanent items necessary for the performance of the contract. This includes all items used for construction, maintenance, and testing as required to fulfill the contractual obligations.
Contractor's Personnel	Shall mean all employees, workers, subcontractors, agents, and any other individuals or entities engaged by the Contractor to perform the works under the contract, including those working at the construction site or any location necessary for the execution of the project.
Contractor's Proposal	Shall mean the detailed submission made by the Contractor in response to the Client's invitation or request, outlining the proposed methodology, work plan, schedule, and cost estimates for executing the works, including any technical or financial terms as required under the contract.

National Highways Infra Trust

	General Conditions of Contract	Doc No.: NHIT/FY25-26/RFP/ Incident Management
---	---------------------------------------	--

Term	Definition
Concessionaire	Shall mean the Contractor under the NHAJ Concession Agreement, responsible for the operation and maintenance of the project after construction.
Construction Works	Shall mean all activities and tasks undertaken by the Contractor to fulfil the requirements of the contract, including both permanent works (such as buildings, structures, and infrastructure) and temporary works (such as scaffolding, formwork, and site facilities), in accordance with the contract specifications, drawings, and applicable standards.
Consultant	Shall mean the professional service provider appointed by the Client to assist in the supervision, design, management, or other project-related activities, providing expert advice, technical expertise, and support in accordance with the terms of the contract.
Date of Handover	Shall mean the date on which the Contractor completes the works in accordance with the contract and formally hands over the completed project to the Client, signifying the transfer of responsibility from the Contractor to the Client.
Delay	Shall mean the failure to complete the works within the agreed completion date, resulting from the Contractor's fault, the Client's actions or omissions, or unforeseen circumstances beyond the control of either party, as defined in the contract.
Design Documents	Shall mean all drawings, specifications, calculations, reports, and other related documents provided by the Contractor, detailing the design of the works, in accordance with the contract requirements.
Dispute	Shall mean any disagreement or conflict arising between the parties regarding the interpretation, application, or breach of the contract terms, which may require resolution as per the procedures outlined in Clause 18 of this GCC.
Dispute Resolution Procedure	Shall mean the process described in Clause 18 of this GCC for addressing disputes, differences, or claims arising under the Contract. It encompasses procedures such as amicable settlement, referral to a Dispute Resolution Board (DRB), and arbitration in accordance with the Arbitration and Conciliation Act, 1996 (as amended). The resolution framework also includes jurisdictional provisions, interim relief, and continuity of work obligations to ensure minimal disruption. Wherever the term "Arbitration" appears in this Agreement, it shall refer to Clause 18 , detailing its application and procedure.
Duties and Responsibilities	Shall mean the obligations and tasks assigned to each party under the contract, encompassing the specific roles, functions, and responsibilities of both the Client and the Contractor as outlined in the contract.
Engineer-in-charge	Shall mean the person appointed by the Employer or its authorized representative to oversee, administer, and certify the execution of work under the Contract. The Engineer-in-Charge shall be responsible for supervising construction, maintenance, material quality, and contract compliance as per the specifications. For consultancy and equipment hiring contracts, the Engineer-in-Charge shall ensure services or hired equipment meet contract terms. The Engineer-in-Charge shall have the authority to issue instructions,

National Highways Infra Trust

	General Conditions of Contract	Doc No.: NHIT/FY25-26/RFP/ Incident Management
---	---------------------------------------	--

Term	Definition
	approve work, and certify completion, subject to the Employer’s final approval. All instructions and approvals given by the Engineer-in-Charge shall be binding on the Contractor unless otherwise directed by the Employer.
Engineer’s Representative	Shall mean the individual appointed by the Engineer to act on their behalf, responsible for overseeing the works, ensuring compliance with the contract, and making decisions related to the construction process.
Employer’s Representative	Shall mean the individual appointed and authorized by the Client to oversee, administer, and manage the contract on behalf of the Client, ensuring compliance with the terms and conditions of the contract.
Emergency Works	Shall mean works required to rectify, mitigate, or respond to situations arising from natural disasters, accidents, or other unforeseen events that demand immediate action to restore safety, functionality, or compliance with the contract.
Employer’s Risk	Shall mean the risks for which the Employer is responsible under the contract, including but not limited to unforeseen site conditions, force majeure events, or any other risks that are outside the Contractor’s control and which may impact the progress or execution of the works.
Escalation Clause	Shall mean the provision in the contract that allows for adjustments to the contract price or rates based on changes in inflation, material costs, labor rates, or other relevant indices, to account for unforeseen increases in costs during the course of the project.
Force Majeure	Shall mean any unforeseeable event or circumstance beyond the control of either party, including but not limited to natural disasters, war, terrorism, floods, strikes, or government actions, which prevents or delays the performance of contractual obligations.
Final Payment	Shall mean the last payment made by the Client to the Contractor upon the successful completion of the contract, including all adjustments for variations, deductions, or any other contractual obligations, after the issuance of the Completion Certificate.
Final Settlement	Shall mean the final agreement between the Contractor and the Client, which marks the conclusion of the contract, including any outstanding payments, claims, or adjustments, and reflects the completion of all contractual obligations by both parties.
Gross Income	Shall mean the total income earned by the Concessionaire from the operation of the project, including all tolls, fees, charges, and other revenues generated from the project, before any deductions or expenses.
Indemnity	Shall mean the obligation of the Contractor to hold harmless and protect the Client from any losses, damages, liabilities, claims, or expenses arising from the Contractor’s actions, negligence, or failure to perform obligations under the contract, including but not limited to any third-party claims.
Insurance	Shall mean the coverage required under the contract to protect the Contractor, Client, and third parties from risks and liabilities during the execution of the works. This includes coverage for damage to works, injury, accidents, loss, theft, and public liability. The Contractor must obtain insurance

National Highways Infra Trust

	General Conditions of Contract	Doc No.: NHIT/FY25-26/RFP/ Incident Management
---	---------------------------------------	--

Term	Definition
	from a reputable insurer and provide proof of such coverage to the Client. The insurance must meet the legal and contractual requirements, ensuring adequate protection against potential risks during the project's duration.
Interim Payment	Shall mean a payment made to the Contractor at regular intervals for work completed up to a certain stage, as specified in the contract, based on progress or milestones achieved, subject to the approval of the Client or Engineer.
Insurance Certificate	shall mean a document issued by an insurance company confirming that the Contractor has obtained and maintained the required insurance coverage as specified in the contract, covering risks such as damage to the works, liability, or other relevant insurable events during the course of the project.
Key Personnel	Shall mean the individuals designated in the contract as essential to the execution of the works, whose expertise, roles, and responsibilities are critical to the successful completion of the project, and whose substitution or replacement requires prior approval from the Client.
Liquidated Damages	Shall mean a predetermined amount specified in the contract, which the Contractor agrees to pay as compensation to the Client for delays or failure to complete the works within the agreed completion date, as a result of the Contractor's default.
Letter of Acceptance	Shall mean the formal document issued by the Client to the Contractor, signifying the Client's acceptance of the Contractor's bid or proposal, thereby forming a binding contract between the parties.
Letter of Intent	Shall mean a written statement from the Employer indicating the Employer's intention to proceed with the execution of the works or part thereof, prior to the formal signing of the contract, without creating any contractual obligations on the part of the Employer except for those specifically agreed in the letter.
Mobilization	Shall mean the activities required to prepare the site, deploy resources, and establish necessary facilities for the commencement of the works. This includes setting up temporary site offices, mobilizing labor, equipment, and materials, and ensuring the availability of utilities and services, as well as fulfilling regulatory and safety requirements, in accordance with the terms of the contract.
Notice of Delay	Shall mean a formal notification issued by the Contractor to the Client or Engineer, informing them of delays or potential delays in the completion of the works. The notice shall detail the cause of the delay, the expected duration, and any actions being taken to mitigate the delay, in accordance with the terms of the contract. The notice must be submitted within the specified time frame as outlined in the contract to ensure proper documentation and potential adjustments to the project schedule.
Notice to Proceed	Shall mean a formal written notice issued by the Client to the Contractor, authorizing the commencement of the works specified in the contract, typically following the contract signing. It marks the official start date for the project and confirms that the Contractor may begin work in accordance with the agreed terms and conditions.

National Highways Infra Trust

	General Conditions of Contract	Doc No.: NHIT/FY25-26/RFP/ Incident Management
---	---------------------------------------	--

Term	Definition
Payment Certificate	Shall mean a document issued by the Engineer or Client, certifying the amount due to the Contractor for the work completed up to a specific date, based on the progress of the work, as per the terms of the contract. The certificate includes details of the work completed, measurements, and any applicable adjustments, deductions, or additions, and serves as the basis for the Contractor's payment claim.
Performance Bond	Shall mean a financial guarantee, typically issued by a bank or insurance company, ensuring the Contractor's fulfilment of the terms and conditions of the contract. The bond serves as security for the Client, covering the cost of completing the work or remedying any defects in case the Contractor fails to perform in accordance with the contract. The bond amount is usually a percentage of the contract value and is released upon successful completion of the contract obligations.
Price Adjustment	Shall mean modifications to the contract price due to fluctuations in material costs, labour, or other factors such as inflation or changes in the scope of work, as defined and agreed upon in the contract.
Progress Payment	Shall mean a periodic payment made to the Contractor based on the measured and certified completion of work, whether calculated as a percentage of the total contract value, as per completed items of work, or as otherwise defined in the contract. Such payments are certified by the Engineer in accordance with the agreed terms.
Request for Proposal	shall mean a formal solicitation document issued by the Client to invite bids for a specified scope of work. It defines project requirements, technical specifications, eligibility criteria, evaluation methodology, and contractual terms governing the bidding process. The RFP ensures transparency, compliance, and fair competition while outlining bid submission, evaluation, and contract award conditions.
Retention	Shall mean a predetermined percentage of the payment due to the Contractor that is withheld by the Client as security to ensure the satisfactory performance and completion of the works, including rectification of any defects during the defect liability period, as specified in the contract.
Site Safety	Shall mean the comprehensive set of measures, practices, and protocols implemented to safeguard the health and safety of all personnel, workers, and the general public during the execution of the works, in compliance with applicable laws, regulations, and contract provisions, including adherence to IRC guidelines and relevant safety standards.
Substantial Completion	Shall mean the stage in the execution of the works where all major components and contractual obligations have been completed to a degree that allows the project to be used or occupied for its intended purpose, notwithstanding the presence of minor defects or incomplete works that do not materially affect functionality, safety, or operability, as determined by the Engineer in accordance with the terms of the contract.
Subcontractor	Shall mean any individual, firm, partnership, or corporation engaged by the Contractor to execute a specified portion of the works or services under the

National Highways Infra Trust

	General Conditions of Contract	Doc No.: NHIT/FY25-26/RFP/ Incident Management
---	---------------------------------------	--

Term	Definition
	contract, in accordance with the approved terms and conditions, and subject to the Contractor's overall responsibility for the completion and performance of the project as per the contract.
Takeover Certificate	Shall mean the formal document issued by the Client, or the Engineer on behalf of the Client, certifying the satisfactory completion of the works or a specified portion thereof in accordance with the contract terms, signifying the Client's acceptance and assumption of responsibility for the works.
Terms of Reference (ToR)	Shall mean a document that defines the scope, objectives, responsibilities, and deliverables for the road construction and maintenance project. It specifies the tasks, such as design, construction, quality control, material specifications, timelines, and resource allocation, to be carried out by the contractor. The ToR operates in conjunction with the General Conditions of Contract (GCC) , Special Conditions of Contract (SCC) , and Contract Data (CD) , which provide the contractual, legal, and procedural guidelines for the project. It ensures that all parties understand their roles, obligations, and expectations while adhering to the project's technical specifications and standards. The ToR serves as a reference for the execution and monitoring of the project, ensuring compliance with the overarching contract documents and applicable standards.
Time Extension	Shall mean an adjustment to the original contract completion date, granted by the Client based on justifiable reasons, such as delays caused by unforeseen circumstances, variations in work scope, or other factors beyond the Contractor's control, in accordance with the provisions of the contract.
Worksite	Shall mean the designated area where the works specified in the contract are to be executed, including all associated locations such as access roads, storage areas, and temporary facilities or structures established by the Contractor for the purpose of completing the works, as defined in the contract documents.
Warranty Period	Shall mean the specified duration following the issuance of the Completion Certificate or Takeover Certificate during which the Contractor is obligated to rectify any defects, deficiencies, or failures in the works, materials, or equipment, ensuring compliance with the contract requirements. This period is defined in the contract and commences upon the formal acceptance of the works by the Client.

2. Scope of Work

2.1 General Scope

The Contractor shall provide all services necessary to carry out road maintenance activities, as outlined in this Agreement. These services shall include routine, preventive, and emergency maintenance, repair, and rehabilitation of the road network, associated structures, and facilities, ensuring their safe and functional condition as specified by the Client. The Contractor shall also be responsible for coordinating with the Client and maintaining records of all work performed.

2.2 Detailed Scope of Works / Services

National Highways Infra Trust

	General Conditions of Contract	Doc No.: NHIT/FY25-26/RFP/ Incident Management
---	---------------------------------------	--

The Contractor's responsibilities under this Agreement shall include, but are not limited to, the following tasks:

- 2.2.1 Routine and Preventive Maintenance:** Perform regular inspections, cleaning, and minor repairs of the road, pavements, shoulders, road signs, road markings, drainage systems, guardrails, and other roadside infrastructure, ensuring compliance with the Client's standards.
- 2.2.2 Emergency Repairs and Restoration:** Respond promptly to unexpected events, such as accidents or weather-related damages, ensuring the road is restored to safe and usable conditions with minimal disruption to traffic.
- 2.2.3 Pavement and Surface Treatment:** Maintain, repair, and rehabilitate the road pavement, including surface treatments, patching of damaged areas, and the replacement of severely damaged sections.
- 2.2.4 Drainage and Stormwater Management:** Ensure the proper functioning of the road's drainage systems, including culverts, drains, and ditches, to prevent water accumulation and maintain road stability.
- 2.2.5 Traffic Signs and Road Markings:** Maintain and replace damaged or faded traffic signs, signals, and road markings in accordance with relevant traffic regulations and standards.
- 2.2.6 Roadside Structures and Bridges:** Maintain the structural integrity of all roadside structures, including bridges, overpasses, underpasses, retaining walls, and other infrastructure, ensuring safe operational conditions.
- 2.2.7 Traffic Management and Safety:** Implement safety measures during road maintenance activities, such as proper traffic management, signages, barriers, and other devices, to ensure safety for road users and workers.
- 2.2.8 Environmental Protection:** Conduct all maintenance activities in a manner that complies with environmental regulations, including proper disposal of waste, pollution control, and minimizing disruption to the surrounding environment.

2.3 Contractor's Obligations

- 2.3.1** The Contractor shall supply all labor, equipment, tools, materials, and expertise required to perform the work under this Agreement.
- 2.3.2** The Contractor shall comply with all relevant local, national, and international laws, regulations, and industry standards related to road maintenance, health and safety, and environmental protection.
- 2.3.3** The Contractor shall ensure that all maintenance work is completed within the prescribed timelines and quality standards specified in this Agreement.

2.4 Coordination and Reporting

- 2.4.1** The Contractor shall coordinate all maintenance activities with the Client and provide timely updates regarding the progress of work, issues identified, emergency responses, and completion status.
- 2.4.2** The Contractor shall submit regular reports detailing all maintenance activities carried out, including a summary of work completed, ongoing tasks, and any emergency interventions.

2.5 Exclusions

This Agreement excludes any major reconstruction, upgrading, or new construction of roads, bridges, or structures unless explicitly specified in a separate written agreement between the Client and the Contractor.

National Highways Infra Trust

 <p>NHIT National Highways Infra Trust</p>	General Conditions of Contract	Doc No.: NHIT/FY25-26/RFP/ Incident Management
---	---------------------------------------	--

3. Contract Period and Validity

3.1 Contract Period

The Contract shall commence on the **Effective Date** as specified in the Agreement and shall remain in force for an initial period of **[as specified in Contract Data Sheet] years/months** (the "Contract Period"), unless terminated earlier in accordance with the provisions of this Agreement. The Contractor shall commence work as specified and shall diligently proceed with the work to ensure that all obligations and deliverables are completed in accordance with the terms and conditions of this Agreement.

3.2 Extension of Contract Period

Upon mutual agreement between the Client and the Contractor, the Contract Period may be extended for additional periods, each not exceeding **[as specified in Contract Data Sheet] years/months**, subject to the terms and conditions agreed upon by both parties. Such extension shall be agreed in writing before the expiry of the initial Contract Period or any subsequent extension period. The extension may be due to reasons such as:

- 3.2.1 The need for continued road maintenance works / services beyond the initial Contract Period.
- 3.2.2 Delays in the completion of work that are beyond the Contractor's control and for which an extension is granted in accordance with the provisions of this Agreement.

3.3 Validity of Contract

This Agreement shall be valid and binding upon the parties from the **Effective Date [as specified in Contract Data Sheet]** until the completion of all obligations and deliverables, unless terminated earlier as per the provisions of this Agreement. The validity of the Contract shall also depend upon the fulfilment of the following:

- 3.3.1 **Performance Security:** The Contractor shall provide a Performance Security **[amount as specified in Contract Data Sheet]** as per the conditions stipulated in this Agreement, which shall remain valid throughout the Contract Period and any extensions thereof.
- 3.3.2 **Compliance with Regulatory Requirements:** The Contract will remain valid provided the Contractor maintains compliance with all applicable laws, regulations, and standards relevant to the performance of road maintenance works / services.

3.4 Survival of Obligations After Termination

Notwithstanding the termination of the Contract, the Contractor's obligations regarding confidentiality, warranties, and indemnities shall survive beyond the termination and continue in full force until satisfied. Any outstanding payments owed by either party to the other at the time of termination shall also survive termination and remain due for settlement.

3.5 Termination and Final Acceptance

In the event of termination of the Contract, the provisions of **Clause 20 (Termination)** shall apply, and in the event of completion of the Contract, the provisions of **Clause 23 (Substantial Completion and Final Acceptance)** shall apply.

4. Contractor's Obligations

4.1 General Obligations

The Contractor shall perform all obligations and services in accordance with the terms of this Agreement and in a professional and efficient manner, ensuring compliance with the

National Highways Infra Trust

 <p>NHIT National Highways Infra Trust</p>	General Conditions of Contract	Doc No.: NHIT/FY25-26/RFP/ Incident Management
---	---------------------------------------	--

Contract Specifications, applicable laws, regulations, and standards, and minimizing disruption to road users and the public.

4.2 **Obligations Relating to Performance and Quality**

The Contractor shall ensure the performance and quality of the road maintenance works / services as per the specifications laid out in the **Scope of Work**. The Contractor shall maintain an efficient **Quality Control (QC) system** and ensure documentation of compliance.

4.3 **Staffing and Resource Management**

The Contractor shall provide sufficient and competent personnel, equipment, and materials to perform the works / services efficiently. The staffing obligations are detailed under **Clause 5 (Contractor's Personnel)**.

4.4 **Health, Safety, and Environmental Requirements**

The Contractor shall comply with health, safety, and environmental regulations, ensuring a safe working environment for all personnel and the public. Obligations in this area are covered in **Clause 11 (Health, Safety, and Environmental Management)**.

4.5 **Insurance Obligations**

The Contractor shall provide and maintain the necessary insurance policies, including public liability, workmen's compensation, and contractor's all-risk insurance, as detailed in **Clause 12 (Insurance)**.

4.6 **Site Management and Supervision**

The Contractor shall be responsible for the management, supervision, and coordination of the work. This is covered under **Clause 25 (Site Management and Supervision)**.

4.7 **Subcontracting**

The Contractor shall not subcontract any part of the work without the prior written approval of the Client. Subcontracting provisions are in **Clause 6 (Subcontracting and Assignment)**.

4.8 **Compliance with Laws and Regulations**

The Contractor shall comply with all applicable laws and regulations, as outlined in **Clause 17 (Governing Law and Jurisdiction)**.

4.9 **Indemnity and Liability**

The Contractor shall indemnify and hold the Client harmless from any claims, damages, or liabilities. The indemnity and liability clauses are covered under **Clause 26 (Indemnity and Liability)**.

4.10 **Reporting and Documentation**

The Contractor shall maintain records and submit regular reports and documentation as required by the Client. Reporting and documentation are covered in **Clause 27 (Reporting and Documentation)**.

4.11 **Maintenance and Performance Standards**

The Contractor shall adhere to the maintenance and performance standards outlined in the **Contract Specifications** and ensure works / services are rendered to maintain road infrastructure as per **Clause 28 (Maintenance and Performance)**.

4.12 **Dispute Resolution**

In case of disputes, the dispute resolution process as per **Clause 18 (Dispute Resolution)** shall apply.

4.13 **Termination of Contract**

In the event of termination, the provisions of **Clause 20 (Termination of Contract)** shall apply.

4.14 **The duties of the contractor**

This shall include compliance with safety standards, quality, environmental, and health regulations as per MoRTH, IRC, and international norms.

National Highways Infra Trust

	General Conditions of Contract	Doc No.: NHIT/FY25-26/RFP/ Incident Management
---	---------------------------------------	--

5. Contractor's Personnel

5.1 Contractor's Responsibility:

The Contractor shall ensure that only qualified, experienced, and competent personnel are deployed for the execution of the Works. All personnel, including management, technical, and support staff, shall be appropriately trained, skilled, and capable of performing the assigned tasks efficiently, in compliance with applicable standards, laws, and regulations.

5.2 Key Personnel:

The Contractor shall provide a list of key personnel who will be assigned to the project, along with their qualifications, experience, and roles. These personnel shall include, but not be limited to, the Project Manager, Site Engineer, Safety Officer, Quality Control Officer, and other specialized personnel as required by the project. The roles and responsibilities of these key personnel shall be clearly defined and communicated to the Client.

5.3 Substitution of Personnel:

In the event of the need to replace or substitute any key personnel, the Contractor must obtain prior written approval from the Client. Any substitution shall be made with personnel of similar or higher qualifications, and the Contractor shall provide adequate justification for such changes. The new personnel must meet the same qualifications and experience criteria as the replaced staff.

5.4 Non-Compliance and Disciplinary Action:

In case the Client finds that any personnel deployed by the Contractor fail to meet the required standards, the Client reserves the right to request their removal from the site. The Contractor shall promptly remove such personnel and replace them with suitable alternatives. Continued non-compliance by the Contractor's personnel may lead to penalties as per the contract, including potential delays or suspension of work.

5.5 Health, Safety, and Welfare:

The Contractor is responsible for ensuring the health, safety, and welfare of all personnel deployed for the project. All personnel must be provided with the necessary personal protective equipment (PPE) and must comply with the safety protocols defined in the Health, Safety, and Environmental (HSE) plan for the project. The Contractor shall also ensure that all personnel undergo safety training and awareness programs as required.

5.6 Workforce Composition:

The Contractor shall provide a balanced workforce for the execution of the Works, including skilled labor, technical staff, and supervisory personnel. The workforce must be adequate to meet the project timeline and ensure continuous work in compliance with the project's quality, safety, and environmental requirements.

5.7 Contractor's Supervision:

The Contractor shall provide a sufficient number of supervisors and management personnel to oversee the work, ensuring compliance with the approved methodologies, safety standards, and project schedules. The Contractor shall also ensure that supervisors are responsible for maintaining quality control and reporting to the Client.

5.8 Employee Welfare and Benefits:

The Contractor shall comply with all relevant labour laws and provide adequate welfare facilities for its personnel, including but not limited to, sanitation, accommodation, transportation (if required), and other benefits as per statutory requirements.

5.9 Exclusivity of Personnel:

The personnel deployed by the Contractor for the project shall not be transferred to other projects without the prior written consent of the Client. This ensures that the project benefits from dedicated and focused human resources.

National Highways Infra Trust

 <p>NHIT National Highways Infra Trust</p>	General Conditions of Contract	Doc No.: NHIT/FY25-26/RFP/ Incident Management
---	---------------------------------------	--

5.10 Compliance with Local Regulations:

All personnel deployed must adhere to the labour laws, safety standards, and environmental regulations that apply to the locality of the project site, in addition to international standards, where applicable.

6. Subcontracting and Assignment

6.1 Subcontracting Approval:

The Contractor shall not subcontract any part of the Works without prior written consent from the Client. All subcontractors must meet the same standards required of the Contractor and adhere to the terms of this contract.

6.2 Contractor's Responsibility:

The Contractor remains fully responsible for the performance of the contract, even when subcontracting. Subcontractors' acts, omissions, and defaults shall be treated as those of the Contractor.

6.3 Assignment and Transfer:

The Contractor shall not assign, transfer, or subcontract the rights or obligations under this contract without the Client's prior written consent. Any unauthorized assignment or transfer shall be void.

6.4 Subcontractor Compliance:

The Contractor must ensure that all subcontractors comply with the terms, standards, and requirements of the contract, including quality, safety, and statutory obligations.

6.5 Notification of Changes:

Any changes to subcontractors must be approved by the Client. The Contractor shall notify the Client in writing of any proposed changes to the subcontractor team.

6.6 Subcontractor's Documentation:

Subcontractors must provide necessary documentation such as progress reports, safety records, and quality assurance certifications as required by the Client. The Contractor is responsible for submitting these on behalf of subcontractors.

6.7 Insurance Requirements:

Subcontractors must carry appropriate insurance coverage as required under the contract, including public liability and workers' compensation. The Contractor must provide proof of insurance on behalf of subcontractors when requested.

6.8 Subcontractor Performance:

The Contractor shall evaluate subcontractor performance to ensure compliance with the contract, quality standards, and timelines. Any performance issues must be addressed immediately, and the Client should be informed of corrective actions.

6.9 Indemnity:

The Contractor shall indemnify the Client against any claims or damages arising from the actions or failures of subcontractors.

7. Risk Allocation

7.1 Client's Risks:

7.1.1 The Client assumes responsibility for risks arising from:

7.1.1.1 Force Majeure: Events beyond the control of either party, such as natural disasters, strikes, wars, or other unforeseen events.

7.1.1.2 Site Conditions: Delays or issues caused by pre-existing site conditions or environmental factors unknown to the Contractor at the time of bid submission.

7.1.1.3 Delays by the Client: Delays caused by late approvals, failure to provide necessary access, or other actions attributable to the Client.

National Highways Infra Trust

 <p>NHIT National Highways Infra Trust</p>	General Conditions of Contract	Doc No.: NHIT/FY25-26/RFP/ Incident Management
---	---------------------------------------	--

7.1.1.4 Design Changes: Modifications or changes to the project's design or scope requested by the Client after contract execution.

7.2 Contractor's Risks:

The Contractor assumes responsibility for risks arising from:

7.2.1 Project Delays: Delays resulting from the Contractor's failure to perform, inadequate resources, or failure to meet agreed milestones.

7.2.2 Unforeseen Site Conditions: Conditions that, although unforeseen, could have been reasonably anticipated by the Contractor at the time of the bid submission.

7.2.3 Workmanship and Quality: Ensuring that the works meet the specified standards, with responsibility for correcting any defects or deficiencies during the construction phase and warranty period.

7.2.4 Compliance with Laws: The Contractor's responsibility for complying with all statutory requirements, regulations, and permits during the course of work.

7.3 Shared Risks:

Certain risks are shared between the Client and Contractor, with allocation based on mutual agreement or contract amendments. These include:

7.3.1 Changes in Law: Risk arising from changes in local or national legislation impacting the execution or cost of the project.

7.3.2 Third-Party Claims: Risks of third-party claims related to the construction process, which may be jointly managed by both parties depending on the cause.

7.4 Risk Cost Purchase (Client's Risk Mitigation Effort):

7.4.1 Risk Management Costs: The Client may incur costs related to purchasing risk management tools or measures, including additional insurance, legal protections, or third-party services to mitigate specific risks identified during the project.

7.4.2 Additional Resources: The Client may provide or purchase additional resources, such as alternative designs or technologies, to mitigate risks related to site conditions, environmental challenges, or delays.

7.4.3 Cost Reimbursement: If the Client elects to purchase such risk mitigation services, any costs incurred may be passed on to the Contractor, subject to prior written approval or agreement on the cost-sharing method.

7.5 Risk Mitigation and Notification:

Both parties are required to actively mitigate risks within their control. Each party must promptly notify the other of any risk factors that could impact the project, including the potential for delay or additional costs. Regular risk assessments must be conducted, and mitigation strategies should be implemented as necessary.

7.6 Force Majeure:

In the event of Force Majeure, the affected party must notify the other party as soon as possible. The contract may be extended, or other adjustments may be made to accommodate the impact of such events.

7.7 Insurance for Risk Management:

National Highways Infra Trust

 <p>NHIT National Highways Infra Trust</p>	General Conditions of Contract	Doc No.: NHIT/FY25-26/RFP/ Incident Management
---	---------------------------------------	--

Both the Client and Contractor must maintain appropriate insurance coverage to mitigate the impact of risks under their respective responsibilities. This includes public liability, contractor all-risk insurance, and other relevant policies.

8. Quality Control and Assurance

8.1 General Obligations

- 8.1.1 The Contractor shall ensure that all works comply with the approved Quality Assurance Plan (QAP), MoRTH, IRC, and other relevant specifications.
- 8.1.2 All materials, workmanship, and methodologies must adhere to the prescribed standards, with no deviations allowed without prior written approval from the Client.
- 8.1.3 The Contractor is fully responsible for the quality of work, including ensuring compliance with technical specifications, design criteria, and project-specific quality benchmarks.

8.2 Quality Assurance Plan (QAP)

- 8.2.1 The Contractor shall submit a comprehensive QAP for Client approval before commencing work. The QAP must include:
 - 8.2.1.1 Roles and responsibilities of personnel involved in quality control.
 - 8.2.1.2 Inspection points, testing protocols, frequency of tests, corrective actions, and defect rectification timelines.
- 8.2.2 The QAP shall also detail mock-ups, trials, and continuous quality monitoring methods.
- 8.2.3 The Contractor must diligently implement the approved QAP and address any changes suggested by the Client.

8.3 On-Site Testing Laboratory

- 8.3.1 The Contractor must establish and operate an on-site testing laboratory with calibrated equipment as per IS and MoRTH standards.
- 8.3.2 Real-time quality tests shall be conducted, and the results documented and shared with the Client.
- 8.3.3 The Client reserves the right to verify results through independent testing at NABL-accredited laboratories.

8.4 Material Source Approval

- 8.4.1 All material sources shall be pre-approved by the Client. The Contractor must submit samples, test results, and certifications for approval before procurement.
- 8.4.2 The Contractor must ensure timely submission of documents to avoid delays.

8.5 Inspection and Testing Protocols

- 8.5.1 All materials and workmanship shall undergo regular inspections and testing as per the QAP.
- 8.5.2 Test frequencies, sampling methods, and acceptance criteria must adhere to MoRTH and project standards.
- 8.5.3 The Client may conduct independent testing or appoint third-party auditors at any stage, with costs borne by the Contractor in case of non-compliance.

8.6 Non-Conformance Management

- 8.6.1 The Contractor shall maintain a system to record and rectify non-conforming work.
- 8.6.2 Non-conforming materials or works must be removed from the site immediately and rectified at the Contractor's expense.

National Highways Infra Trust

 <p>NHIT National Highways Infra Trust</p>	General Conditions of Contract	Doc No.: NHIT/FY25-26/RFP/ Incident Management
---	---------------------------------------	--

8.6.3 Repeated quality issues will result in escalation as follows: written warnings, penalties, and, if unresolved, suspension of work.

8.7 Defects Rectification and Timelines

8.7.1 Identified defects must be rectified within timelines specified in the QAP or technical documents.

8.7.2 Failure to comply within these timelines may result in penalties, suspension of work, or termination of the contract.

8.8 Documentation and Reporting

8.8.1 The Contractor shall maintain updated records of all quality control activities, including inspection reports, test results, calibration certificates, and supplier certifications.

8.8.2 Periodic quality reports (daily, weekly, or monthly as specified) shall be submitted to the Client.

8.8.3 Handover documentation, including material certifications, test reports, inspection records, and warranties, must be submitted at project completion for final approval.

8.9 Continuous Improvement Measures

8.9.1 The Contractor shall adopt continuous improvement practices, including regular reviews of quality outcomes and training personnel on quality standards.

8.9.2 Feedback mechanisms must be established to identify recurring quality issues and implement corrective actions.

8.10 Penalties for Quality Non-Compliance

8.10.1 Failure to meet quality standards or address defects promptly shall result in penalties as per the contract.

8.10.2 Substandard quality, delays in defect rectification, or repeated non-conformance may also lead to work suspension or termination.

8.11 Client's Oversight and Rights

8.11.1 The Client reserves the right to conduct inspections, tests, and reviews at any stage, including surprise checks.

8.11.2 Additional testing at NABL-accredited laboratories may be mandated at the Contractor's cost in cases of suspected non-compliance.

8.11.3 Third-party audits may be conducted, with any resulting penalties or costs borne by the Contractor for non-compliance.

9. Work Execution and Methodology

9.1 General Obligations

9.1.1 The Contractor shall carry out all **road construction, periodic maintenance, and routine maintenance** works in strict compliance with the approved work methodologies, schedules, and technical specifications as per MoRTH guidelines, IRC standards, and the relevant contract documents.

9.1.2 The Contractor is responsible for ensuring that all work is executed in line with the prescribed road maintenance procedures, safety protocols, quality benchmarks, and environmental standards. Any deviations from these shall be subject to prior written approval from the Client.

National Highways Infra Trust

 <p>NHIT National Highways Infra Trust</p>	General Conditions of Contract	Doc No.: NHIT/FY25-26/RFP/ Incident Management
---	---------------------------------------	--

9.1.3 For the purpose of broad guidelines, the following brief methodology is being provided for reference. **The Contractor shall submit a detailed maintenance methodology at least 30 days before execution of the work for the Client's approval.**

9.2 Road Construction Methodology

Road construction shall be executed in accordance with MoRTH, IRC, and NHA I Schedule-F specifications, ensuring high-quality, durable pavements capable of sustaining traffic loads as per design life requirements. The methodology shall comprehensively cover earthwork, embankment formation, pavement layers, drainage structures, road safety appurtenances, and associated works. The Contractor shall ensure that all construction activities are planned, executed, and monitored as per approved designs, work methodologies, and safety protocols. All quality control tests shall be conducted as per specified standards, and the work shall be inspected by the Client or its authorized representatives at various stages.

9.2.1 Scope and Requirements

The Contractor shall execute all new road construction and major rehabilitation works in accordance with MoRTH, IRC, and NHA I Schedule-F specifications. The methodology shall cover embankment preparation, pavement layers, drainage, structures, and road safety features.

9.2.2 Subgrade and Pavement Layers

The Contractor shall ensure that subgrade, granular sub-base (GSB), wet mix macadam (WMM), bituminous layers (DBM, BC, etc.), and concrete layers (PQC, DLC, etc.) are laid as per approved designs and quality control norms.

9.2.3 Earthwork and Embankment Preparation

Before pavement construction, all earthwork and embankment preparation shall follow MoRTH specifications, including compaction testing, slope stabilization, and proper drainage provisions.

9.2.4 Drainage and Structural Components

The construction of culverts, drains, bridges, and retaining walls shall be carried out in line with approved drawings and IRC/MoRTH specifications. Proper curing and structural integrity checks shall be conducted before road opening.

9.2.5 Traffic Management during Construction

The Contractor shall implement a temporary traffic diversion plan to ensure smooth traffic flow and road user safety. Temporary roads or bypasses shall be constructed as required.

9.3 Bridge and Structural Construction Methodology

The construction of bridges, culverts, ROBs, and other structures shall be carried out in accordance with MoRTH, IRC, and BIS standards, ensuring structural integrity, durability, and safety. The Contractor shall follow approved designs and specifications, ensuring strict quality control at every stage, from foundation work to superstructure completion.

The methodology shall cover all aspects of bridge and structural construction, including substructure and superstructure works, material selection, quality control measures, safety procedures, and traffic management during construction. The execution shall comply with MoRTH, IRC, and BIS standards, ensuring durability, stability, and road user safety.

9.3.1 Substructure and Foundation Works

- i. The Contractor shall ensure that all excavation, piling, and foundation works are carried out as per the approved design and site conditions.

National Highways Infra Trust

 <p>NHIT National Highways Infra Trust</p>	General Conditions of Contract	Doc No.: NHIT/FY25-26/RFP/ Incident Management
---	---------------------------------------	--

- ii. Piling (bored cast-in-situ or driven) shall be executed using the appropriate methodology, maintaining verticality and ensuring proper reinforcement cage placement.
- iii. For shallow foundations, the excavation depth and bearing strata shall be verified before concreting.
- iv. Abutments and piers shall be constructed using high-strength concrete, ensuring proper curing and reinforcement cover as per IRC and MoRTH specifications.

9.3.2 Superstructure Erection

- i. The erection of girders (precast or cast-in-situ) shall follow an approved lifting and launching scheme, ensuring proper alignment and structural stability.
- ii. Deck slab construction shall ensure adequate formwork support, reinforcement placement, and proper curing.
- iii. Prestressing operations, if applicable, shall be carried out as per IRC:18 and MoRTH standards, ensuring proper tensioning and grouting.

9.3.3 Expansion Joints and Bearings

- i. The Contractor shall install expansion joints and bearings as per the approved design, ensuring correct alignment and proper seating.
- ii. Bearing pads (elastomeric, pot, or spherical) shall be placed with precision, and their compressibility shall be verified before final placement.
- iii. Expansion joints shall be sealed properly to prevent water ingress and joint deterioration.

9.3.4 Finishing Works and Safety Features

- i. Crash barriers, handrails, and parapets shall be installed as per IRC:5 and MoRTH guidelines.
- ii. The bridge deck shall be waterproofed using approved membranes or asphaltic coatings.
- iii. Approach roads shall be integrated seamlessly, ensuring proper drainage and smooth transition between road and bridge sections.

9.3.5 Traffic and Environmental Management during Construction

- i. The Contractor shall ensure proper diversion routes and barricading during construction, as per the approved traffic management plan.
- ii. Dust suppression measures shall be implemented during excavation and material handling.
- iii. Waste materials shall be disposed off safely in compliance with environmental regulations.

9.4 Periodic Maintenance Methodology

Periodic maintenance activities are essential for ensuring the longevity, durability, and functional efficiency of the road infrastructure. These works shall include surface renewal, overlaying, strengthening, milling & resurfacing, crack sealing, and preventive maintenance measures to enhance pavement performance and road safety. The Contractor shall execute all periodic maintenance works in compliance with MoRTH, IRC, and NHAI Schedule-F guidelines. The methodology shall focus on proper surface preparation, material selection, quality assurance, and minimization of disruptions to traffic. Any deviations or modifications in the planned methodology shall require prior approval from the Client.

9.4.1 Scope and Objectives

Periodic maintenance shall include surface renewal, overlaying, strengthening, milling & resurfacing, crack sealing, and other preventive measures to extend pavement life.

9.4.2 Surface Preparation before Resurfacing

National Highways Infra Trust

 <p>NHIT National Highways Infra Trust</p>	General Conditions of Contract	Doc No.: NHIT/FY25-26/RFP/ Incident Management
---	---------------------------------------	--

The Contractor shall undertake thorough surface cleaning, removal of loose material, and application of prime/tack coats as per MoRTH standards before overlaying new pavement layers.

9.4.3 Milling and Resurfacing

If resurfacing is required, existing asphalt layers shall be milled as per the required depth before new bituminous layers are laid. The Contractor shall ensure proper bonding between layers.

9.4.4 Strengthening of Pavement

For pavement strengthening, the Contractor shall execute overlaying or additional layers (BM, DBM, BC) as per the approved design mix, ensuring compaction and density control.

9.4.5 Inspection and Testing

Core sampling, density tests, and roughness index tests shall be conducted to verify compliance with specified quality standards.

9.5 Periodic Maintenance of Bridges and Structures

Periodic maintenance of bridges, culverts, ROB, and structures is critical to ensuring their longevity, structural safety, and functionality. The Contractor shall conduct systematic inspections, repairs, and preventive maintenance activities as per MoRTH Schedule-F, IRC, and BIS guidelines.

The methodology shall include inspection protocols, maintenance procedures for bearings and expansion joints, concrete repair techniques, waterproofing measures, and traffic safety arrangements. All maintenance activities shall be performed as per MoRTH Schedule-F, IRC:SP:35, and other relevant standards to ensure the long-term serviceability and structural integrity of bridges, culverts, and ROB.

9.5.1 Inspection and Structural Assessment

- i. The Contractor shall conduct periodic inspections of all bridges, culverts, and ROB as per IRC:SP:35 and MoRTH Schedule-F.
- ii. Structural integrity checks shall include visual inspections, load testing (if required), and material condition assessment.
- iii. Any signs of distress, such as cracks, spalling, or deflections, shall be documented, and corrective measures shall be proposed.

9.5.2 Bearing and Expansion Joint Maintenance

- i. Bearings shall be inspected for signs of displacement, corrosion, or excessive deformation.
- ii. Lubrication and cleaning of bearings shall be performed as per manufacturer recommendations.
- iii. Expansion joints shall be cleaned, re-sealed, or replaced if damaged, ensuring smooth movement of the structure.

9.5.3 Concrete Repairs and Strengthening Measures

- i. Deteriorated concrete shall be repaired using polymer-modified mortars or epoxy-based solutions.
- ii. Carbon fibre wrapping or steel plate bonding shall be used for strengthening weak structural elements.
- iii. Proper curing shall be ensured after repairs to achieve the required strength and durability.

9.5.4 Waterproofing, Drainage, and Corrosion Protection

- i. Deck waterproofing membranes shall be inspected and repaired if damaged.

National Highways Infra Trust

	General Conditions of Contract	Doc No.: NHIT/FY25-26/RFP/ Incident Management
---	---------------------------------------	--

- ii. Drainage pipes and scuppers shall be cleaned to prevent water accumulation on the bridge deck.
- iii. Anti-corrosion coatings shall be applied to exposed reinforcement and steel elements to prevent deterioration.

9.5.5 Traffic and Public Safety Management during Maintenance

- i. Temporary lane closures shall be planned to minimize disruption to traffic.
- ii. Proper signage, barricading, and flagmen shall be deployed to guide road users safely.
- iii. The Contractor shall coordinate with local authorities to ensure compliance with safety regulations.

9.6 Detailed Maintenance Methodology

9.6.1 The Contractor shall submit a comprehensive Road Maintenance Methodology Plan for the Client's approval before commencement. This plan must include detailed processes for each maintenance activity, including surface repair, crack filling, patching, resurfacing, drainage maintenance, and any other works as per the scope.

9.6.2 The plan should detail the sequence of operations, methods, materials to be used, equipment, and labor deployment. It must also outline the methodology for managing road closures, traffic control, and diversion routes during maintenance work.

9.6.3 Any changes to the approved methodology must be submitted for Client approval before implementation.

9.7 Routine Maintenance Execution

9.7.1 The Contractor shall ensure that the maintenance works, such as pothole repairs, crack sealing, surface dressing, resurfacing, patch repairs, and drainage cleaning, are carried out as per MoRTH and IRC standards, ensuring road safety and minimal disruption to traffic.

9.7.2 Specific procedures for each type of work (e.g., resurfacing, pothole filling, crack sealing) shall be outlined in the methodology, and work shall proceed strictly as per the sequence and conditions specified.

9.7.3 For resurfacing works, the Contractor must ensure that existing road surface preparation is adequate, including milling, cleaning, and priming, as per the IRC and MoRTH specifications.

9.8 Emergency Repairs Under Routine Maintenance

While routine maintenance includes activities such as pothole filling, crack sealing, and minor surface repairs, **emergency repair works necessitated by unforeseen events**—such as floods, landslides, major accidents, or structural failures—require a structured response.

In the event of an emergency affecting the highway infrastructure, the contractor shall:

- i. **Immediate Response:** Mobilize resources within **[2] hours** of notification to assess the damage and ensure temporary traffic management measures for public safety.
- ii. **Reporting & Coordination:** Notify the Authority Engineer immediately and submit a preliminary damage assessment report within **[6] hours**, detailing the nature and extent of damage.
- iii. **Temporary & Permanent Restoration:** Execute immediate safety measures, including temporary traffic diversions, barricading, and urgent patchwork. Permanent repairs shall follow within the timeframe stipulated by the Authority Engineer.
- iv. **Material & Cost Considerations:** The contractor shall maintain a stockpile of essential materials and deploy necessary manpower and equipment for emergency response. The

National Highways Infra Trust

 National Highways Infra Trust	General Conditions of Contract	Doc No.: NHIT/FY25-26/RFP/ Incident Management
--	---------------------------------------	--

cost of such emergency repairs, if beyond the scope of routine maintenance, shall be addressed as per contractual provisions.

All emergency repair activities must comply with relevant MoRTH specifications and safety guidelines, ensuring minimal disruption to traffic and structural integrity of the highway.

9.9 Approval Process for Deviations

In cases where deviations from the approved maintenance plan, materials, methodology, or schedule are necessary, the contractor shall obtain prior approval from the Client or Authority Engineer. The approval process shall be as follows:

- i. **Standard Approvals:** Any planned deviation must be submitted in writing, including justification, impact assessment, and proposed corrective measures. The Client/Authority Engineer shall review and respond within **[10] working days** from submission.
- ii. **Urgent & Emergency Deviations:** For urgent situations requiring immediate action (e.g., safety hazards, emergency repairs), the contractor may seek **verbal approval** from the Authority Engineer. Such approvals must be recorded in writing within **[24] hours**, followed by formal documentation within **[5] working days**.
- iii. **Record-Keeping & Compliance:** All approved deviations shall be documented for compliance with contractual provisions and MoRTH specifications. Unauthorized deviations may result in penalties or rejection of work.

9.10 Material Selection and Handling

9.10.1 All materials used for road maintenance must meet MoRTH and IRC specifications, with the Contractor required to submit material samples and obtain Client approval prior to procurement.

9.10.2 Materials must be sourced from approved suppliers, and the Contractor shall maintain documentation for certification of compliance with MoRTH, IRC, and relevant BIS standards.

9.10.3 Proper handling and storage of materials, such as bitumen, aggregates, and cement, must be ensured to maintain their quality and prevent contamination or deterioration.

9.11 Timely Execution and Scheduling

9.11.1 Maintenance work shall be executed as per the approved work schedule, ensuring that critical road maintenance activities such as resurfacing and patching are completed within the stipulated timeframes to avoid prolonged disruption to road users.

9.11.2 Any delay in the completion of work must be reported to the Client immediately, along with a revised schedule and reasons for the delay. The Contractor must take immediate corrective actions to mitigate delays.

9.12 Site Mobilization and Readiness

9.12.1 The Contractor shall mobilize necessary resources, including equipment, skilled labor, and materials, before starting the work to ensure site readiness. This includes setting up of temporary safety barriers, signage, and traffic control systems as per the approved traffic management plan.

9.12.2 Temporary diversion routes and road closures, if necessary, must be coordinated with the Client and relevant local authorities to ensure smooth traffic flow during the maintenance period.

9.13 Quality Control during Execution

9.13.1 Quality control measures must be strictly adhered to at all stages of work. The Contractor shall conduct in-situ testing, such as core sampling, compaction testing, and bitumen content testing, in accordance with MoRTH specifications.

National Highways Infra Trust

 <p>NHIT National Highways Infra Trust</p>	General Conditions of Contract	Doc No.: NHIT/FY25-26/RFP/ Incident Management
---	---------------------------------------	--

9.13.2 For major maintenance works such as resurfacing or surface dressing, the Contractor must verify the compaction, uniformity, and adhesion of the new layer with the underlying surface.

9.13.3 The Contractor must implement a system of daily inspections and testing to monitor the quality of materials, workmanship, and progress.

9.14 Health, Safety, and Environmental Considerations

9.14.1 The Contractor is responsible for ensuring that all work is carried out in compliance with the health, safety, and environmental standards outlined in the approved Safety Management Plan.

9.14.2 Measures must be implemented to minimize dust, noise, and other pollutants during work, and the site must be regularly cleaned **to maintain safety and environmental standards.**

9.14.2.1 Environmental Compliance

- i. The contractor shall ensure that all maintenance activities comply with environmental regulations as per **Central Pollution Control Board (CPCB) and State Pollution Control Board (SPCB) guidelines.** The following measures shall be strictly implemented:
- ii. **Dust Suppression:** Regular water sprinkling, use of dust barriers, and other appropriate measures shall be adopted, particularly during sweeping, pothole repairs, and unpaved shoulder maintenance.
- iii. **Waste Management:** Debris, removed vegetation, and other waste materials shall be collected, segregated, and disposed of at designated locations as per SPCB norms. No waste shall be dumped in drains, water bodies, or road shoulders.
- iv. **Noise & Air Pollution Control:** Construction equipment and vehicles shall comply with prescribed emission and noise limits. Unnecessary idling of machinery shall be avoided.
- v. **Spill Prevention:** Proper handling and disposal of hazardous materials, including bitumen and oil spills, shall be ensured to prevent contamination of soil and water.
- vi. **Compliance & Monitoring:** The contractor shall maintain records of environmental protection measures undertaken and make them available for inspection by the Client/Authority Engineer.
- vii. Non-compliance may result in penalties as per contract provisions.

9.14.3 The Contractor shall ensure that adequate signage, barriers, and flagmen are deployed to ensure road user safety during work.

9.15 Traffic Management and Public Communication

9.15.1 The Contractor shall submit a detailed traffic management plan as part of the methodology, outlining road closure procedures, detour routes, signages, and safety measures for public protection.

9.15.2 Any changes to traffic management must be promptly communicated to the Client and local authorities.

9.15.3 Public notices regarding roadwork schedules, diversions, and alternate routes must be issued by the Contractor to ensure minimum inconvenience to the public.

9.16 Inspection and Supervision

9.16.1 The Contractor shall ensure that qualified supervisory staff are on-site at all times to oversee daily operations, ensuring work quality, safety, and adherence to the methodology.

9.16.2 The Client or its authorized representative reserves the right to inspect the work at any stage. Any defects or deviations identified shall be corrected by the Contractor at their expense.

National Highways Infra Trust

 <p>NHIT National Highways Infra Trust</p>	General Conditions of Contract	Doc No.: NHIT/FY25-26/RFP/ Incident Management
---	---------------------------------------	--

9.17 Non-Conformance and Corrective Action

- 9.17.1** In case of non-conformance to the approved methodology or technical specifications, the Contractor must take immediate corrective actions and notify the Client of the remedial measures.
- 9.17.2** Failure to correct defects within the specified timeframe will result in penalties, suspension of work, or other contractual remedies as outlined in the contract.

9.18 Reporting and Documentation

- 9.18.1** The Contractor shall submit daily and weekly progress reports, highlighting completed activities, quality checks, resource utilization, and any issues encountered during work.
- 9.18.2** The Contractor must maintain all records related to material procurement, testing, inspections, and any approvals from authorities for the duration of the project.

9.19 Completion and Handover

- 9.19.1** Upon completion of the maintenance work, the Contractor shall ensure that the site is fully cleaned, all temporary structures are removed, and the road is safely reopened for traffic.
- 9.19.2** The Contractor shall submit a completion report, including details of all maintenance work carried out, materials used, quality checks performed, and any outstanding issues to the Client for final approval.

10. Materials and Equipment

10.1 General Requirements

- 10.1.1** The Contractor shall supply all materials and equipment required for the execution of new construction, periodic maintenance, and routine maintenance of roadworks and electrification systems. This includes materials necessary for construction, rehabilitation, resurfacing, installation, repair, and maintenance activities, as well as the tools and machinery needed to perform these activities.
- 10.1.2** All materials and equipment must conform to the specifications outlined in MoRTH, IRC, relevant IS codes, and the approved Quality Assurance and Quality Control Plan (QA/QC Plan) as per **Clause 8**.

10.2 Materials

- 10.2.1** All materials required for new construction, periodic maintenance, and routine maintenance of roadworks and electrification systems must be sourced from approved suppliers and meet the prescribed standards. The materials shall conform to MoRTH, IRC, relevant IS codes, and the approved Quality Assurance and Quality Control Plan (QA/QC Plan).
- 10.2.1.1 Materials include, but are not limited to:**
- i. **Roadworks (New Construction & Maintenance):** Bitumen, aggregates, cement, reinforcement steel, geotextiles, concrete admixtures, paint, road signs, reflective materials, thermoplastic road markings, joint sealants, drainage pipes, and ancillary construction materials.
 - ii. **Electrification Works:** Poles, transformers, cables, streetlight fixtures, junction boxes, electrical wires, electrical control panels, earthing systems, and accessories.

- 10.2.2** The Contractor shall submit **samples, manufacturer test certificates, and third-party laboratory test reports** for all materials before use to ensure compliance with project specifications. If any material fails to meet the prescribed standards, it shall be **immediately rejected**, and the Contractor shall replace it with a conforming alternative **at their own expense and without affecting project timelines**.

National Highways Infra Trust

 <p>NHIT National Highways Infra Trust</p>	General Conditions of Contract	Doc No.: NHIT/FY25-26/RFP/ Incident Management
---	---------------------------------------	--

10.3 Equipment for Execution and Maintenance

10.3.1 General Requirements

The Contractor shall deploy suitable, **calibrated, and well-maintained** equipment for **new construction, periodic maintenance, and routine maintenance** of roadworks and electrification systems. Equipment shall conform to the **MoRTH, IRC, relevant IS codes, and the approved QA/QC Plan**.

Equipment shall include but is not limited to:

- i. **Roadworks (New Construction & Maintenance):** Graders, pavers, rollers, excavators, milling machines, asphalt plants, bitumen sprayers, chip spreaders, road cutters, hot mix transporters, crack sealing machines, and surface dressing equipment.
- ii. **Electrification Works:** Cranes, hoists, lifting machines, cable pullers, welding machines, pole erection rigs, auger drilling machines, fault detection equipment, and transformer testing kits for streetlight and electrical system installation and maintenance.

10.3.2 Equipment Submission and Maintenance

The Contractor shall submit a **comprehensive list** of all equipment required for the project, including **calibration records and maintenance logs**, ensuring that all equipment is properly maintained and in **good working condition**.

Equipment must be:

- i. **Adequate for efficient and safe execution** of all tasks.
- ii. **Regularly serviced and calibrated** to ensure compliance with project requirements.
- iii. **GPS-enabled for tracking** (if applicable) to monitor utilization and ensure operational efficiency.
- iv. **Immediately replaced in case of malfunction**, to avoid project delays.

10.3.3 Equipment Fitness and Preventive Maintenance

All deployed equipment shall be:

- i. **Fit for the intended purpose** and capable of performing the assigned tasks.
- ii. **Regularly inspected, tested, and serviced** to minimize breakdowns and downtime.
- iii. **Maintained proactively** as per manufacturer guidelines to avoid unexpected failures.
- iv. **Kept operational and available at all times** to meet project demands efficiently.

10.4 Quality Assurance and Testing of Materials

10.4.1 The Contractor shall ensure that all materials used in roadworks construction, maintenance and electrification comply with the approved **Quality Assurance and Quality Control (QA/QC) Plan**. The Contractor shall submit **source approvals, manufacturer test certificates (MTC), and on-site test reports** for all materials prior to their use. The quality control and testing of materials shall be conducted in accordance with the applicable provisions of **MoRTH, IRC, IS codes, and project-specific technical specifications**. Where required, testing shall be carried out by independent **NABL-accredited** laboratories.

10.4.2 Any material that fails to meet the specified requirements shall be deemed **non-compliant** and shall be immediately removed from the site at the Contractor's cost. The Contractor shall replace such material with compliant material from an **approved source**, ensuring that no additional cost is incurred by the Client.

National Highways Infra Trust

 <p>NHIT National Highways Infra Trust</p>	General Conditions of Contract	Doc No.: NHIT/FY25-26/RFP/ Incident Management
---	---------------------------------------	--

10.4.3 The Contractor shall maintain comprehensive records of all **test results, approvals, and compliance certificates** and shall submit these to the Client upon request. The Client reserves the right to inspect and verify the materials at any stage of procurement, delivery, or installation.

10.5 Storage and Handling of Materials and Equipment

10.5.1 The Contractor shall ensure that all materials and equipment are **stored, handled, and protected** in a manner that prevents **damage, deterioration, contamination, or theft**. Storage facilities shall be designed to maintain materials in their original condition and comply with relevant **safety, environmental, and manufacturer's guidelines**.

10.5.2 Materials shall be stored in designated areas, with specific provisions as follows:

i. **Roadworks Materials:**

a. **Bitumen and Cement** shall be stored in **covered, dry, and well-ventilated spaces** to prevent contamination and deterioration.

b. **Aggregates** may be stored in **open spaces**, duly protected from contamination and excessive moisture.

ii. **Electrical Components** (e.g., transformers, cables, control panels) shall be stored in **weather-protected, moisture-free environments**, ensuring compliance with the manufacturer's storage guidelines.

10.5.3 The Contractor shall implement appropriate **handling procedures** to prevent damage during **loading, unloading, and transportation**. All equipment shall be stored and maintained in accordance with the **manufacturer's recommendations** to ensure its proper functionality and longevity.

10.5.4 The Client reserves the right to **inspect storage and handling procedures** at any time and may direct corrective measures if deficiencies are identified. Any material or equipment found damaged, defective, or improperly stored shall be **immediately replaced or rectified** at the Contractor's cost.

10.6 Non-Conformance of Materials and Equipment

10.6.1 Any materials or equipment that fail to comply with the approved specifications, quality standards, or contractual requirements shall be deemed non-conforming and shall not be used in the project.

10.6.2 Upon identification of non-conforming materials or equipment, whether through inspection, testing, or performance evaluation, the Contractor shall:

i. Immediately remove the defective materials or equipment from the site.

ii. Rectify or replace the non-conforming items at their own cost, without affecting the project timeline.

iii. Ensure that all replacements strictly adhere to the approved specifications and quality control requirements.

10.6.3 If the Contractor fails to remove or replace the defective materials or equipment within the stipulated timeframe, the Client shall have the right to procure conforming replacements at the Contractor's risk and expense, and any associated costs shall be recovered from the Contractor.

10.6.4 The Client reserves the right to reject any material or equipment at any stage if it is found non-compliant, even after initial approval or installation. The Contractor shall be solely responsible for any delays, damages, or costs arising due to the use of non-conforming materials or equipment.

National Highways Infra Trust

	General Conditions of Contract	Doc No.: NHIT/FY25-26/RFP/ Incident Management
---	---------------------------------------	--

10.7 Client's Rights to Inspect and Test

10.7.1 The Client reserves the right to inspect and test all materials, equipment, and systems (roadworks, electrification) at any stage. If any non-compliance or deficiencies are identified, the Client may require corrective actions, including replacement or repair of materials or equipment at the Contractor's expense.

10.8 Documentation and Reporting

10.8.1 The Contractor must maintain accurate and up-to-date records of all materials supplied, equipment deployed, and testing conducted. This includes certifications, inspection reports, maintenance logs, calibration records, and material test results. The Contractor shall submit regular progress reports to the Client, detailing the status of material procurement, equipment deployment, and any issues related to materials or equipment.

11. Health, Safety, and Environmental Requirements

11.1 Compliance

The Contractor shall comply with all applicable health, safety, and environmental laws, regulations, and standards, including but not limited to those outlined by local authorities, MoRTH, and IRC. The Contractor is responsible for ensuring the safety of all personnel and for maintaining a safe working environment at all times, including the provision of necessary safety equipment, training, and emergency preparedness measures. All works shall be carried out in accordance with the Health, Safety, and Environmental (HSE) guidelines as detailed in the **Health, Safety, and Environmental Requirements document**. The Contractor shall also ensure compliance with environmental protection measures, including the management of waste, pollution control, and resource conservation.

For detailed HSE protocols, please refer to the **Health, Safety, and Environmental document**.

12. Insurance and Liability

12.1 Contractor's Insurance Requirements

The Contractor shall maintain, at their own expense, the following insurances throughout the term of the Contract and ensure that they are in full force and effect at all times during the execution of the work:

12.2 Workmen's Compensation Insurance

The Contractor shall procure and maintain adequate Workmen's Compensation Insurance to cover all liabilities arising under statutory provisions and at common law for injuries to or death of persons employed under the Contract. Proof of insurance shall be submitted to the Client prior to the commencement of the work.

12.3 Contractor All Risk (CAR) Insurance

The Contractor shall obtain and maintain a Contractor All Risk (CAR) Insurance policy covering all risks associated with the execution of the works, including but not limited to physical damage to the works, equipment, and third-party property. This insurance shall remain valid until the issuance of the final completion certificate.

12.4 Other Insurances

Additional insurances, if required, such as Public Liability Insurance or Third-Party Liability Insurance, shall be explicitly specified in the **Special Conditions of Contract (SCC)**. In such cases, the Contractor shall ensure compliance as per the SCC's stipulations.

National Highways Infra Trust

	General Conditions of Contract	Doc No.: NHIT/FY25-26/RFP/ Incident Management
---	---------------------------------------	--

12.5 Proof of Insurance

Copies of all required insurance policies and proof of premium payments shall be submitted to the Client within seven days of the contract award and before the commencement of work.

12.6 Failure to Insure

In case the Contractor fails to procure or maintain the required insurance policies, the Client reserves the right to procure such insurances and deduct the cost from payments due to the Contractor, along with applicable penalties.

12.7 Indemnity

The Contractor agrees to indemnify and hold harmless the Client against any claims, damages, losses, or liabilities arising from the Contractor's negligence, omissions, or failure to comply with the terms of this contract. This includes claims related to third-party injuries, property damage, or environmental damage due to the Contractor's actions or lack of adequate precautions.

12.8 Insurance Documentation and Proof

12.8.1 The Contractor shall provide the Client with valid certificates of insurance for all required policies prior to the commencement of work. The insurance policies must be maintained for the duration of the contract and for a period of time post-completion as specified in the contract.

12.8.2 The Client reserves the right to verify and review all insurance coverage at any time. The Contractor shall immediately notify the Client of any cancellation, non-renewal, or change in insurance coverage.

12.9 Additional Insurances

The Contractor is responsible for obtaining any additional insurance that may be necessary for the completion of specific works under this contract, including any unforeseen risks that may arise during road maintenance works / services.

12.10 Liabilities and Limitations

12.10.1 The insurance coverage must not limit the Contractor's liabilities or responsibilities under the terms of the contract.

12.10.2 The Contractor shall remain liable for any risks that fall outside the scope of the insurance coverage.

12.10.3 The Client shall not be held liable for any damage or loss that is covered under the Contractor's insurance policies, nor for any failure by the Contractor to secure adequate insurance coverage.

12.11 Specific Insurance for Road Maintenance Works

In addition to the general types of insurance listed above, **road maintenance works** have additional specific risks, particularly related to safety, traffic management, and environmental impacts. Therefore, the following should be included to cover roadworks effectively:

12.11.1 Traffic Management Insurance: To cover incidents or accidents occurring due to changes or disruptions in traffic patterns caused by road maintenance work.

12.11.2 Roadwork Hazards Insurance: Coverage for accidents occurring due to the nature of roadwork, including risks to workers and the public from construction equipment, excavations, or surface treatments.

12.11.3 Hazardous Material Handling Insurance: Specifically for projects involving the disposal of hazardous materials such as asphalt, chemicals, or other waste generated during roadworks.

National Highways Infra Trust

 <p>NHIT National Highways Infra Trust</p>	General Conditions of Contract	Doc No.: NHIT/FY25-26/RFP/ Incident Management
---	---------------------------------------	--

13. Labor Laws and Statutory Compliance

13.1 General Compliance

The Contractor shall comply with all applicable labour laws, regulations, and statutory requirements as per the laws of the land, including but not limited to:

- i. The **Contract Labor (Regulation and Abolition) Act, 1970** and its amendments.
- ii. The **Employees' Provident Funds and Miscellaneous Provisions Act, 1952**.
- iii. The **Employees' State Insurance Act, 1948**.
- iv. The **Minimum Wages Act, 1948**.
- v. The **Payment of Wages Act, 1936**.
- vi. The **Workmen's Compensation Act, 1923** or its amended equivalents.
- vii. The **Factories Act, 1948** (where applicable).
- viii. Any other applicable state or central labor legislation.

13.2 Wage Payment and Benefits

The Contractor shall ensure that all workers employed under the contract are paid wages not less than the prescribed minimum wages and are provided with benefits such as Provident Fund, Employee State Insurance, gratuity, and other statutory benefits as mandated by applicable laws.

13.3 Labor Licenses and Registrations

The Contractor shall obtain and maintain valid labor licenses, registrations, and permits required under applicable labor laws and provide copies to the Client upon request.

13.4 Health, Safety, and Welfare

The Contractor shall ensure the welfare of workers by providing adequate safety measures, sanitary facilities, clean drinking water, first aid, and hygienic working conditions in compliance with statutory requirements. The Contractor shall comply with the provisions of the **Building and Other Construction Workers (Regulation of Employment and Conditions of Service) Act, 1996** and the rules framed thereunder, including any welfare cess.

13.5 Prohibition of Child and Forced Labor

The Contractor shall not employ any person below the age of 18 years and ensure that no forced or bonded labour is engaged. The Contractor shall strictly comply with the provisions of the **Child Labor (Prohibition and Regulation) Act, 1986**.

13.6 Compliance Monitoring and Reporting

The Contractor shall maintain accurate records of all labour engaged on the project, including wages paid, hours worked, and statutory benefits provided. The Contractor shall furnish periodic reports as requested by the Client to demonstrate compliance with labor laws and statutory requirements.

13.7 Labor Disputes and Resolution

The Contractor shall be solely responsible for resolving any disputes arising with workers or unions and shall ensure that such disputes do not disrupt project activities or create liabilities for the Client.

13.8 Indemnification

The Contractor shall indemnify and hold harmless the Client from and against any liabilities, penalties, claims, or proceedings arising out of any breach of labour laws or statutory requirements by the Contractor or their subcontractors.

13.9 Penalty for Non-Compliance

In case of non-compliance with labor laws or statutory requirements, the Client reserves the right to impose penalties, deduct amounts from payments due to the Contractor, or terminate the contract without prejudice to other rights and remedies.

National Highways Infra Trust

 <p>NHIT National Highways Infra Trust</p>	General Conditions of Contract	Doc No.: NHIT/FY25-26/RFP/ Incident Management
---	---------------------------------------	--

13.10 Specific to Road Maintenance

Given the nature of road maintenance work, the Contractor shall:

- i. Provide safety gear such as high-visibility jackets, helmets, gloves, and safety boots to all workers.
- ii. Ensure adequate training for workers handling machinery, hazardous materials, or working in traffic zones.
- iii. Comply with traffic management protocols to ensure worker and public safety during maintenance activities.

14. Payment Terms and Conditions

14.1 General

The Contractor shall be entitled to receive payments for the works executed, subject to certification by the Client or the Engineer-in-Charge. **The payment structure, whether percentage-based, lump-sum, or BoQ-based item rate, shall be as per the type of contract and detailed in the Contract Data Sheet.** This clause provides an indicative framework for various payment scenarios.

14.2 Payment on Percentage Basis

In case the contract stipulates percentage-based payments, the Contractor shall receive payments in predefined stages linked to the completion of specific milestones, as outlined in the **Contract Data Sheet**. Each stage payment shall be proportional to the overall contract value and subject to certification of the milestone achievement.

14.3 Lump-Sum Payment

In case of lump-sum contracts, payments shall be made as per the agreed milestones or deliverables, as detailed in the **Contract Data Sheet**. Each payment shall be subject to satisfactory progress and certification by the Client. Any variations in scope shall be addressed through additional work orders or amendments, as applicable.

14.4 BoQ-Based Item Rate Payment

In case the contract follows a Bill of Quantities (BoQ) item rate basis, the Contractor shall be paid based on actual quantities executed and certified at the agreed unit rates as per the BoQ. Measurements for executed works shall conform to the applicable IS and MoRTH standards.

14.5 Retention Money

A retention amount, typically a percentage of each payment, shall be deducted and retained as security until successful completion of the works, including defect liability and final acceptance by the Client. The retention money shall be released along with the final bill upon satisfactory completion of all contractual obligations, including rectification of any defects during the defect liability period.

14.6 Advance Payments

Any advance payments, if applicable, shall be detailed in the SCC and subject to recovery through subsequent payments as per agreed terms.

14.7 Payment Certification and Conditions

Payments shall be subject to:

- i. Submission of detailed invoices along with supporting documents.
- ii. Certification by the Client or the Engineer-in-Charge for works completed.
- iii. Compliance with contractual obligations, including quality, safety, and statutory requirements.

National Highways Infra Trust

	General Conditions of Contract	Doc No.: NHIT/FY25-26/RFP/ Incident Management
---	---------------------------------------	--

14.8 Taxes and Deductions

All payments shall be subject to statutory deductions such as TDS, GST, or any other applicable taxes as per prevailing laws.

14.9 Final Bill Settlement

The final bill, including the release of retention money, shall be settled after:

- i. Submission of all as-built drawings, test reports, and warranties.
- ii. Clearance of all dues related to subcontractors, suppliers, and workers.
- iii. Certification by the Client of successful completion of works, including the defect liability period.

14.10 Interim Payment Method and Requirements

Interim payments shall be processed periodically, as specified in the contract, to ensure timely reimbursement for the work executed. The Contractor shall submit interim invoices along with the required documentation, including measurement sheets, progress reports, and certifications of work completed. Each interim payment shall be subject to verification and certification by the Engineer-in-Charge, ensuring compliance with the contract specifications, quality standards, and milestones achieved. Retention money, as applicable, shall be deducted from each interim payment, and all statutory deductions, such as taxes, shall be applied as per prevailing laws. It is expressly clarified that all interim payments are provisional and shall not be considered final. These payments are subject to final reconciliation, adjustments, or modifications, as required, in the final bill to reflect the actual work performed, material consumed, and compliance with all contract obligations.

14.11 Submission of Documentation Along with Invoice

14.11.1 For Interim Payments

To process interim bills, the Contractor must submit the following:

A. Work-Related Documentation:

- a) **Measurement Sheets** signed by the Contractor's representative and verified by the Client's representative.
- b) **Inspection Reports** confirming adherence to Quality Assurance and Quality Control Plans (as per **Clause 8**).
- c) **Test Reports and Material Certificates** for all materials utilized during the invoiced period.
- d) **Progress Photographs** showcasing completed works corresponding to the invoice.
- e) **Approved Work Orders and Variations**, if applicable.

B. Statutory Compliance Documentation:

- a) **Wage Registers** and attendance records for labor deployed during the period.
- b) **PF and ESI Deposit Receipts** for the period covered by the invoice.
- c) **Labor Licenses** applicable to the workforce engaged in the project.
- d) **Insurance Compliance Certificates** as per contractual requirements.

14.11.2 For Final Bill

In addition to the above, the following must be submitted:

A. Work-Related Documentation:

- a) **Final Reconciliation Statement** of materials, quantities, and payments.
- b) **Equipment Utilization Records** for all deployed equipment throughout the project.
- c) **Variation and Extra Work Documentation** including Client-approved change orders.

B. Statutory Compliance Documentation:

- a) **Acknowledgment of No Claims** from the Contractor, confirming no outstanding claims.
- b) **Safety Compliance Records** including training records and reports of any incidents.

National Highways Infra Trust

 <p>NHIT National Highways Infra Trust</p>	General Conditions of Contract	Doc No.: NHIT/FY25-26/RFP/ Incident Management
---	---------------------------------------	--

- c) **Environmental Compliance Reports**, if applicable.
- d) **Retention and Deduction Summary** for retained amounts, advances, and penalties, if any.

Failure to submit the required documents may delay invoice processing. The Contractor is responsible for the timely submission of accurate and complete documentation.

15. Performance Standards and Penalties

15.1 Performance Standards

The Contractor shall ensure that all works and services under this contract are executed in strict compliance with:

- i. **MoRTH Specifications for Road and Bridge Works (Latest Revision).**
- ii. **Relevant IRC Standards and IS Codes.**
- iii. **Contractual obligations outlined in this Agreement.**
- iv. **Health, Safety, and Environmental (HSE) requirements (Clause 11).**

The scope of performance under this contract includes but is not limited to:

15.1.1 Road Construction and Maintenance

- i. Execution of **road construction, resurfacing, periodic and routine maintenance** in compliance with approved drawings, designs, and specifications.
- ii. Timely and quality completion of **pothole repairs, crack sealing, shoulder maintenance, and pavement rehabilitation.**
- iii. Ensuring **drainage structures (culverts, stormwater drains, etc.) are functional and free of obstructions** throughout the contract period.
- iv. Maintenance of **roadside infrastructure, including crash barriers, guardrails, embankments, and signage.**

15.1.2 Electrical Works

- i. **Installation, maintenance, and operation** of street lighting systems, high-mast lights, transformers, and power supply infrastructure.
- ii. Ensuring that streetlights have **minimum 98% operational uptime**, with faulty units repaired or replaced within the response time.

15.1.3 Safety and Environmental Compliance

- i. Implementation of **proper traffic management, barricading, and warning signs** during work execution.
- ii. Adherence to **CPCB and SPCB environmental regulations**, including **dust suppression, waste disposal, and pollution control measures.**
- iii. Compliance with **statutory safety provisions** to prevent workplace hazards and ensure public safety.

15.2 Minimum Performance Requirements

The Contractor shall meet the following **minimum performance standards**, ensuring timely and quality execution of all works:

15.2.1 Road Maintenance Performance Standards

Activity	Maximum Response Time
Pothole repairs	24 hours from identification/reporting
Crack sealing & patchwork	48 hours from reporting
Shoulder maintenance	72 hours after deterioration is reported
Drainage clearing	Before & after monsoon, periodic check every 3 months

National Highways Infra Trust

 National Highways Infra Trust	General Conditions of Contract	Doc No.: NHIT/FY25-26/RFP/ Incident Management
--	---------------------------------------	--

Road markings & signage	Maintained in reflective condition at all times
-------------------------	---

15.2.2 Electrical System Performance Standards

Activity	Maximum Response Time
Streetlight repair	48 hours from reporting
Transformer/panel fault repair	72 hours from reporting
Operational uptime for lighting systems	Minimum 98% uptime required

Non-compliance with these performance requirements shall attract penalties as per **Clause 15.4**.

15.3 Monitoring and Inspection

The Contractor shall conduct **regular inspections and performance evaluations** as per the approved Maintenance Plan, which shall include:

1. **Daily inspections** for routine maintenance (potholes, cracks, road markings, signage, and lighting).
2. **Weekly inspections** for structural elements, including drains, safety barriers, and electrical systems.
3. **Monthly inspections** for periodic maintenance planning, material quality checks, and service life assessments.
4. **Post-completion monitoring of rectified works**, ensuring durability as per Clause 28.4.

All inspections shall be documented as per **Clause 27 (Reporting and Documentation)**, and the Contractor shall rectify any identified deficiencies **within the stipulated response time**, failing which penalties shall apply as per Clause 15.4.

Recurring defects or repeated failures in previously rectified areas shall be closely monitored to ensure compliance with quality standards.

15.4 Penalties for Non-Compliance

The following penalties shall be imposed in case of failure to meet the specified performance standards:

15.4.1 Delay in Completion of Works

- i. If the Contractor **fails to complete scheduled construction or maintenance work** within the agreed timeline, a penalty of **[0.5] % of the contract value per day of delay** shall be imposed, up to a maximum of **[10] % of the contract value**.

15.4.2 Road Maintenance Non-Compliance

Deficiency	Penalty
Failure to repair potholes within 24 hours	₹[X] per pothole per day
Cracks & patchwork not completed within 48 hours	₹[X] per defect per day
Failure to clear drainage in stipulated time	₹[X] per km per day
Non-maintenance of faded/damaged signage	₹[X] per sign per day

- i. If a defect reappears in the same location within the defect liability period, the Contractor shall extend its performance guarantee for that section as per Clause 24.

National Highways Infra Trust

 <p>NHIT National Highways Infra Trust</p>	General Conditions of Contract	Doc No.: NHIT/FY25-26/RFP/ Incident Management
---	---------------------------------------	--

- ii. Failure to maintain the rectified section will attract additional penalties, which shall be deducted from the performance security or monthly invoices.

15.4.3 Electrical System Failures

Deficiency	Penalty
Non-functional streetlights beyond 48 hours	₹[X] per pole per day
Transformer/panel failures beyond 72 hours	₹[X] per unit per day
Failure to maintain 98% uptime for lighting systems	₹[X] per month as a lump sum deduction

15.4.4 Safety Violations

Violation	Penalty
Failure to implement safety measures (barricades, traffic diversion, warning signs, etc.)	₹[X] per location per day
Any incident causing injury/property damage due to safety non-compliance	As per EHS Policy
Repeated safety violations	Escalated penalties + possible work suspension

Penalties shall be **deducted from the Contractor's monthly invoice or performance security.**

15.5 Grace Period for Rectification

- i. The Client **may allow a grace period of [7] days** for rectification of **minor defects**, provided they do not impact public safety or overall project timelines.
- ii. No penalty shall be imposed during this period, but the **Contractor shall bear all rectification costs.**

15.6 Cumulative Penalties and Termination

- i. If the cumulative penalties imposed on the Contractor exceed **[5] % of the total contract value**, the Client reserves the right to **terminate the contract** under **Clause 20 (Termination for Default)**.
- ii. The Client shall have the right to **recover additional costs and damages** for non-performance.

15.7 Documentation of Penalties and Appeals

All penalties shall be **formally documented and notified** to the Contractor. The penalty notice shall include:

- i. **Details of the non-compliance.**
- ii. **Applicable performance standard and response time.**
- iii. **Penalty amount and reference clause.**

The Contractor shall have the right to **appeal within [15] days** of receiving the penalty notice, submitting **supporting evidence for reconsideration**. The Client shall review the appeal and decide on **waiving, reducing, or upholding** the penalty. The Client's decision shall be **final and binding** unless an alternate dispute resolution mechanism is specified in the contract.

16. Amendments and Variations

16.1 Change Management Framework

National Highways Infra Trust

	General Conditions of Contract	Doc No.: NHIT/FY25-26/RFP/ Incident Management
---	---------------------------------------	--

All Amendments and Variations under this Agreement shall be governed by a structured Change Management framework to ensure transparency, accountability, and compliance with the contractual terms. The framework shall serve as the guiding principle for initiating, processing, and implementing Amendments and Variations. The Change Management process involves:

- a) **Identification of Change:** Both parties shall identify any changes required in the scope, cost, or timelines of the contract.
- b) **Evaluation and Assessment:** Changes shall be evaluated for their technical, financial, and schedule impacts in accordance with the processes outlined in this clause.
- c) **Approval and Implementation:** Changes shall only be implemented upon written approval by the Client, following the procedures detailed in **Clause 16.3**.
- d) **Documentation:** All changes, including approved Variations and Amendments, shall be formally documented and included in the contractual records.

This Change Management Framework establishes the overarching principles under which all Amendments and Variations shall be handled as specified in this clause.

16.2 Definition of Amendments and Variations

For the purpose of this Agreement, the term "Amendment" refers to any change to the terms, conditions, scope, or requirements of this contract that is agreed upon by both parties, whereas "Variation" refers to any alteration, addition, or omission in the work or services required under this contract, as directed by the Client in writing during the performance of the contract.

16.3 Initiation of Variations

Variations may be initiated under the following circumstances:

16.3.1 Client-Initiated Variations

The Client may, at any time, request the Contractor to carry out variations to the work through a formal written instruction. These may include, but are not limited to, changes in the scope of work, design modifications, or adjustments to specifications or schedule.

16.3.2 Contractor-Initiated Variations

The Contractor may propose a variation in case of unforeseen circumstances, including technical difficulties, material unavailability, or changes in statutory regulations that require adjustments to the original scope of work. Such proposals must be submitted in writing and subject to the Client's approval.

16.3.3 Force Majeure

In cases where events beyond the control of either party (such as natural disasters, governmental actions, etc.) affect the performance of the contract, a variation may be necessary to accommodate the resulting changes in work or schedule.

16.4 Process for Issuing a Variation or Amendment

16.4.1 Written Request

- i. Any proposed variation or amendment must be communicated through a formal written request by the initiating party (Client or Contractor). The request shall include:
 - a. A detailed description of the proposed change.
 - b. Justification for the variation (e.g., technical necessity, statutory compliance, unforeseen circumstances).
 - c. The expected impact on cost, schedule, and scope.

National Highways Infra Trust

 <p>NHIT National Highways Infra Trust</p>	General Conditions of Contract	Doc No.: NHIT/FY25-26/RFP/ Incident Management
---	---------------------------------------	--

16.4.2 Impact Assessment:

Upon receipt of a variation request:

- i. **If initiated by the Client**, the Contractor shall submit a detailed **Impact Assessment Report** within **[7] days**. This report shall include:
 - a. A **detailed description** of the variation.
 - b. The **impact on the scope of work**, materials, and design.
 - c. A **comprehensive cost estimate**, including:
 - **Breakdown of costs** (labor, materials, and equipment).
 - **Rate analysis** for any new items.
 - **Comparison with the original scope**—if the revised work is cheaper, the Contractor shall indicate the applicable discount.
 - d. **Impact on the project schedule**, including adjustments to milestones.
 - e. Any **other relevant contractual or technical considerations** affecting execution.
- ii. **If initiated by the Contractor**, the request shall include:
 - a. **Justification for the variation**, such as technical feasibility, material unavailability, regulatory changes, or unforeseen site conditions.
 - b. **Proposed scope of change**, including any design modifications.
 - c. **Rate analysis and cost impact**, broken down into labor, material, and equipment costs.
 - d. **Impact on the project schedule**, including any required extension of time.
 - e. **Any supporting technical documentation**, such as drawings, calculations, or statutory approvals, if applicable.

The Client shall review the request and seek clarifications within **[15] days**, if necessary. The Contractor shall then submit the **complete impact assessment** within **[15] days** from the Client's request for additional details.

The Contractor shall not proceed with the variation until formal written approval is granted by the Client.

16.4.3 Approval of Variation:

- i. The **Client** shall review the assessment and either approve, reject, or request modifications within **[30] days**.
- ii. If the variation is **Contractor-initiated**, the Client may either approve or suggest modifications, considering the project's feasibility and budget constraints.
- iii. **No work related to the variation shall commence unless a formal Variation Order (VO) is issued.**

16.4.4 Variation Order (VO):

Upon Client approval, the Variation Order shall be issued, specifying:

- a) The scope and nature of the variation.
- b) The agreed-upon adjustments to cost and schedule.
- c) Any necessary changes to other contract terms or conditions.

The VO shall form an integral part of the contract, and the Contractor shall proceed with the work as per the revised terms.

16.4.5 Finalization and Agreement:

National Highways Infra Trust

	General Conditions of Contract	Doc No.: NHIT/FY25-26/RFP/ Incident Management
---	---------------------------------------	--

Once the Variation Order is issued, both parties shall agree to the revised terms in writing, and the work shall proceed in accordance with the approved changes. Any financial or schedule adjustments will be incorporated into subsequent payments as per the agreed-upon terms in the Variation Order.

16.5 Cost and Payment for Variations

All variations shall be priced as follows:

16.5.1 Unit Rates or Lump Sum:

Variations shall be priced based on the existing unit rates or lump-sum rates in the contract. If unit rates are not applicable, the Contractor shall submit a detailed breakdown of costs for labor, materials, and equipment, which shall be subject to Client approval.

16.5.2 Cost Adjustment:

In cases where the original contract price cannot be used as a basis for the variation, the parties shall mutually agree on the appropriate cost adjustment. The Client reserves the right to request supporting documentation for any cost increase.

16.5.3 Retention of Rights:

The approval of a variation does not waive the Client's right to deduct penalties or enforce any contractual obligations related to the original scope of work. Any additional costs due to variations shall be subject to the retention of any agreed retention amounts.

16.6 Time Implications of Variations

16.6.1 Extension of Time (EoT):

If a variation impacts the project timeline, the Contractor shall request an extension of time in accordance with the provisions of **Clause 21 (Extension of Time)**. The Client shall consider the justification for the extension based on the impact of the variation.

16.6.2 Delays Due to Variations:

Any delay in approval or execution of variations caused by either party shall not be considered as an excusable delay for the purpose of an extension of time unless the delay is due to reasons beyond control, such as force majeure.

16.7 Variation Documentation and Records

Both parties shall maintain detailed records of all variations, including:

- i. Copies of all Variation Orders (VOs).
- ii. Documentation of cost and time adjustments.
- iii. Correspondence and agreements related to the variation.

The Contractor shall provide a detailed update of the variations in every progress report and billing cycle, ensuring transparency and adherence to the amended scope and timelines.

16.8 Dispute Resolution for Variations

In case of any dispute regarding the scope, cost, or impact of a variation, the matter shall be resolved in accordance with the dispute resolution mechanism set forth in **Clause 18 (Dispute Resolution)**. Pending resolution, the Contractor shall continue to perform the work in accordance with the Variation Order.

National Highways Infra Trust

 <p>NHIT National Highways Infra Trust</p>	General Conditions of Contract	Doc No.: NHIT/FY25-26/RFP/ Incident Management
---	---------------------------------------	--

17. Governing Law and Jurisdiction

This Agreement shall be governed by, and construed in accordance with, the laws of India. The parties hereby agree that any disputes, claims, or controversies arising out of or in connection with this Agreement, including its validity, interpretation, enforcement, or performance, shall be subject to the exclusive jurisdiction of the courts in New Delhi, India. The parties' consent to the jurisdiction of the courts of New Delhi and waive any objections based on venue or forum non convenienc. All legal proceedings under this Agreement shall be conducted in the English language.

18. Dispute Resolution

18.1 Dispute Notification and Procedure

The Contractor shall notify the Client in writing within 7 days of the occurrence of any dispute, difference, or claim that requires resolution. The notice should clearly detail the nature of the dispute, relevant facts, and the legal or factual basis for the claim. Upon receipt of the dispute notice, the Client and Contractor shall engage in discussions for a period not exceeding 30 days to attempt an amicable settlement.

18.2 Amicable Settlement

In the event of any dispute, difference, or claim arising between the Client and the Contractor in connection with or related to the Contract, the parties shall first attempt to resolve such dispute amicably through mutual consultation and negotiation. The party initiating the dispute (the "Notifying Party") shall notify the other party in writing, clearly outlining the nature and scope of the dispute. Both parties shall make all reasonable efforts to settle the dispute, amicably, within 30 days from the date of notification.

If the dispute remains unresolved after this period, the decision of the Client's CEO shall be final and binding on both parties. Should the decision of the Client's CEO not be acceptable, and the dispute persists, the matter shall proceed to the Dispute Resolution process as outlined below.

18.3 Dispute Resolution Board (DRB)

If the dispute remains unresolved after the amicable settlement period, the dispute shall be referred to a Dispute Resolution Board (DRB).

- a) The DRB will be constituted solely from the senior management team of the Client at its Head Office (HO). No external person or third party will be involved in this process.
- b) The DRB shall be tasked with reviewing the dispute and providing a recommendation or resolution within 45 days from the date the dispute is referred to it. The decision of the DRB shall be binding on both parties unless challenged under the Arbitration clause below.
- c) In the event the DRB fails to resolve the dispute within the prescribed time, or if either party is dissatisfied with the DRB's decision, the dispute will proceed to arbitration.

18.4 Arbitration

If the dispute remains unresolved after mediation, the dispute shall be referred to and resolved through arbitration in accordance with the provisions of the Arbitration and Conciliation Act, 1996, as amended from time to time.

- a) **In cases where the disputed amount is up to INR 1.5 Crore**, the arbitration shall be conducted by a sole arbitrator appointed by the Client.

National Highways Infra Trust

 <p>NHIT National Highways Infra Trust</p>	General Conditions of Contract	Doc No.: NHIT/FY25-26/RFP/ Incident Management
---	---------------------------------------	--

- b) **In cases where the disputed amount exceeds INR 1.5 Crore**, three arbitrators shall be appointed. One arbitrator shall be appointed by the Client, one by the Contractor, and the third arbitrator shall be appointed by the two previously appointed arbitrators. In case the two arbitrators fail to agree on the appointment of the third arbitrator, the third arbitrator shall be appointed by the relevant arbitration institution in New Delhi.
- c) The arbitration proceedings shall be held in New Delhi, India, and the language of arbitration shall be English. The arbitrator's decision shall be final and binding on both parties. The cost of arbitration, including the arbitrator's fees, shall be borne equally by the parties unless otherwise awarded by the arbitrator.

18.5 Jurisdiction and Venue

The courts at Delhi, India, shall have exclusive jurisdiction over all disputes and legal proceedings arising from or relating to the Contract. Both parties expressly consent to the jurisdiction of the courts at Delhi for the purpose of enforcement of any judgment or award.

18.6 Interim Relief

Notwithstanding the above, either party may seek interim relief from a court of competent jurisdiction at any time before or during the dispute resolution process, in order to preserve its rights or prevent any irreparable damage or harm.

18.7 No Suspension of Work

The Contractor shall continue with the performance of its obligations under the Contract, including the Works, during the dispute resolution process unless the Client has issued a formal suspension order. Non-payment of money or non-performance of obligations by the Client shall not relieve the Contractor of its responsibilities to continue the work.

19. Force Majeure

19.1 Definition

Force Majeure shall mean any extraordinary event or circumstance beyond the reasonable control of the affected party that prevents or delays the performance of its contractual obligations. These events may include, but are not limited to, acts of God, natural disasters (such as floods, earthquakes, or storms), acts of war, terrorism, riots, civil commotion, government orders, pandemics, or any other unforeseen event that cannot be mitigated through reasonable diligence.

Notification

The party affected by a Force Majeure event shall notify the other party in writing within seven (7) days of the occurrence of such an event, providing reasonable details of its nature, likely duration, and impact on performance. Failure to notify within this period may result in the loss of the right to claim Force Majeure relief.

19.2 Consequences of Force Majeure

- a) The obligations of the affected party shall be suspended for the duration of the Force Majeure event, to the extent that they are directly impacted by it.
- b) Both parties shall use all reasonable efforts to mitigate the effect of the Force Majeure event and resume performance of their obligations as soon as practicable.

National Highways Infra Trust

	General Conditions of Contract	Doc No.: NHIT/FY25-26/RFP/ Incident Management
---	---------------------------------------	--

- c) If the Force Majeure event continues for a period exceeding ninety (90) days, either party may terminate the contract upon written notice to the other party.

19.3 Exclusions

Force Majeure shall not include:

- a) Any event caused by the negligence or intentional act of the affected party.
- b) Economic hardship, changes in market conditions, or lack of funds.

19.4 Extension of Time

If the Contractor's performance is delayed due to a Force Majeure event, the Contractor shall be entitled to an extension of time equivalent to the period of delay, subject to approval by the Client.

19.5 Payments During Force Majeure

The Contractor shall not be entitled to claim compensation or additional payments due to Force Majeure events unless explicitly agreed upon in the contract or otherwise required under applicable law.

19.6 Final Determination

Any disputes regarding the application of this clause shall be resolved in accordance with **Clause 18** (Dispute Resolution).

20. Termination of Contract

20.1 Termination by the Client

The Client may terminate the Contract, in whole or in part, with immediate effect or after a specified notice period, in the following circumstances:

20.1.1 Non-Performance: If the Contractor fails to meet contractual obligations, including delays or substandard performance, after receiving a written notice to cure the breach within a period specified in the Contract.

20.1.2 Breach of Terms: In case of material violation of any terms or conditions of the Contract, including but not limited to safety standards, statutory compliance, or quality assurance requirements.

20.1.3 Insolvency: If the Contractor becomes insolvent, enters into bankruptcy proceedings, or undergoes dissolution, liquidation, or similar financial distress events.

20.1.4 Force Majeure: If Force Majeure conditions continue for more than ninety (90) days, making further performance impracticable.

20.1.5 Convenience of the Client: The Client reserves the right to terminate the Contract for convenience, provided reasonable compensation for work performed up to the date of termination is made.

20.1.6 Termination for Default:

In case of default by the Contractor, the Client reserves the right to terminate the Contract, either in whole or in part, by giving written notice. Default includes the following:

- a) **Non-Performance:** Failure to meet key contractual obligations, including delays in execution or substandard work, despite receiving a notice to cure within a period specified in the Contract.
- b) **Breach of Terms:** Failure to comply with any material provisions of the Contract, including statutory, safety, or quality assurance requirements.

National Highways Infra Trust

 <p>NHIT National Highways Infra Trust</p>	General Conditions of Contract	Doc No.: NHIT/FY25-26/RFP/ Incident Management
---	---------------------------------------	--

- c) **Insolvency or Financial Distress:** If the Contractor enters into insolvency, bankruptcy, liquidation, or similar financial distress, or any situation that materially impacts its ability to fulfil its obligations under this Contract.

Upon such termination, the following shall apply:

- a) **Notice to Cure:** A written notice shall be issued to the Contractor, specifying the nature of the default. The Contractor will be granted a cure period of 15 days (or as specified in the Special Conditions of Contract) to remedy the default. Failure to rectify the default within the cure period will lead to immediate termination.
- b) **Penalties and Compensation:** The Client may impose penalties of up to **5% of the Contract value** for non-performance or failure to meet standards. The Contractor shall be liable to compensate the Client for any costs incurred due to the default, including but not limited to the cost of procuring alternate contractors to complete the work.
- c) **Withholding of Payments:** The Client has the right to withhold payments corresponding to incomplete, defective, or unsatisfactory work performed prior to termination.

Termination under this clause is without prejudice to any other legal or contractual rights available to the Client, including claims for damages and performance guarantees.

20.2 Termination by the Contractor

The Contractor may terminate the Contract by providing a written notice, subject to fulfilling its obligations until the termination date, in the following circumstances:

- 20.2.1 Non-Payment:** If the Client fails to pay undisputed invoices for a period exceeding One Hundred & Eighty (180) days after they become due, despite receiving written notice.
- 20.2.2 Client Hindrance:** If the Client repeatedly obstructs the Contractor's performance by failing to provide access, approvals, or other essential resources as specified in the Contract.
- 20.2.3 Force Majeure:** If Force Majeure conditions persist beyond Ninety (90) days, rendering performance impossible.

20.3 Procedure for Termination

- 20.3.1 Notice of Intent:** A party initiating termination shall issue a formal written notice detailing the grounds for termination and the intended termination date, allowing a minimum of thirty (30) days for remedial action unless otherwise specified.
- 20.3.2 Efforts to Resolve:** The parties shall engage in good-faith discussions during the notice period to address and resolve the stated issues.
- 20.3.3 Confirmation of Termination:** If the issues remain unresolved by the end of the notice period, the initiating party shall issue a final termination notice, effectively ending the Contract.

20.4 Post-Termination Obligations

- 20.4.1 Cease Work:** The Contractor shall cease all work immediately except for activities required to protect the works already executed or to comply with statutory obligations.
- 20.4.2 Return of Assets:** All equipment, materials, designs, and other assets belonging to the Client shall be returned or securely handed over within seven (7) days of termination.
- 20.4.3 Payments:** The Client shall settle payments for verified work performed up to the termination date, subject to deductions for any damages, penalties, or liabilities.

20.5 Liabilities Upon Termination

- 20.5.1 Contractor's Liabilities:** The Contractor shall bear the cost of demobilization, removal of equipment, and site clearance unless otherwise agreed.

National Highways Infra Trust

	General Conditions of Contract	Doc No.: NHIT/FY25-26/RFP/ Incident Management
---	---------------------------------------	--

20.5.2 Client's Liabilities: In cases of termination for convenience, the Client shall pay reasonable compensation for expenses directly attributable to the termination. Reasonable compensation is limited to:

- 20.5.2.1** Costs for completed works and verified quantities based on contract rates.
- 20.5.2.2** Documented and substantiated costs for materials procured specifically for the project, provided these materials are handed over to the Client.
- 20.5.2.3** Actual and reasonable costs incurred for demobilization and site clearance.
- 20.5.2.4** Compensation shall exclude anticipated profits on unexecuted work, costs due to the Contractor's default, and any claims not supported by documentary evidence. Total compensation shall not exceed 10% of the original contract value. Claims for compensation must be submitted within 30 days of termination with all supporting documents, subject to verification by the Client.

20.6 Survival of Provisions

Provisions relating to confidentiality, indemnities, dispute resolution, warranties, and other obligations explicitly stated to survive termination shall remain enforceable.

20.7 Dispute Arising from Termination

Any disputes related to or arising from termination shall be resolved as per **Clause 18** (Dispute Resolution).

21. Extension of Time

21.1 Request for Extension:

The Contractor shall apply for an extension of time in writing if the completion of work is delayed due to any of the following reasons, which are not attributable to the Contractor's fault:

- a) Unforeseen Force Majeure events, including but not limited to natural calamities, war, civil disturbances, strikes, etc.
- b) Changes in the scope of work, design modifications, or delays in instructions from the Client.
- c) Delays in the availability of land or necessary permissions from local authorities.
- d) Delays in the supply of materials or equipment by the Client.
- e) Any other circumstances as agreed upon in the Special Conditions of Contract.

21.2 Time Extension Request Procedure:

The Contractor must submit a written request for an extension of time, detailing the reasons for the delay, its impact on the project schedule, and any supporting documentation (e.g., reports, correspondence). Such requests must be made within **seven (7) days** from the occurrence of the event causing the delay. The Client shall review the request and provide a written decision within a reasonable period.

21.3 Approval and Grant of Extension:

The Client may grant an extension of time if the delay is caused by factors beyond the Contractor's control. Upon approval, the Contractor's completion date shall be extended for the period equal to the delay, subject to the terms of this Clause. No extension of time shall be granted for delays caused by the Contractor's own fault, negligence, or failure to manage the work.

National Highways Infra Trust

 National Highways Infra Trust	General Conditions of Contract	Doc No.: NHIT/FY25-26/RFP/ Incident Management
--	---------------------------------------	--

21.4 No Financial Compensation:

An extension of time granted under this clause does not entitle the Contractor to any financial compensation or additional costs unless specifically agreed upon in writing by the Client and outlined in the Special Conditions of Contract.

21.5 Liquidated Damages during Extension:

In case of delay beyond the extended time granted, the Contractor shall be liable to pay **Liquidated Damages as specified in Clause 30** of this Agreement. The extension of time does not absolve the Contractor of its responsibility to meet the revised completion dates and obligations under the Contract.

21.6 Client's Right to Terminate for Prolonged Delay:

If the delay exceeds a period of **[refer contract data sheet] months** or extends beyond a point where the completion of the work is no longer feasible, the Client reserves the right to terminate the Contract under **Clause 20.1.5** (Termination for Convenience) or **Clause 20.1.6** (Termination for Default), as applicable.

22. Price Variation / Escalation

Price escalation shall be applicable to contracts with a duration exceeding twelve (12) calendar months.

22.1 Scope of Price Variation

Price variation (Escalation / De-escalation) shall apply to the work under this Contract in the event of changes in the prices of materials, labor, fuel, and equipment during the Contract period, based on the indices and benchmarks specified below. Price variation shall be payable for the work executed within the **original contract period** and shall not apply to work performed beyond the contract period or during any extension of time unless specifically agreed upon by both parties in writing.

22.2 Escalation Calculation Formula

The price variation shall be calculated based on the following formula:

$$P.V. = 0.85RW \times \sum \left(\left(\frac{C_n - B_n}{B_n} \right) \times W_n \right)$$

Where:

RW = Invoice Value i.e. Value of work done & certified for the work completed

P.V. = Price Variation (Escalation/De-escalation) as a percentage of the total value of work executed.

C_n = Current price of the relevant component (labor, material, fuel, or equipment) for the nth item.

B_n = Base price (original agreed rate) of the relevant component (labor, material, fuel, or equipment) for the nth item.

W_n = Weight of the nth item, representing the proportion of that component in the total contract value.

22.3 Escalation Components and Basis

22.3.1 Labor Escalation (PL)

	Page 49 of 73	
--	---------------	--

National Highways Infra Trust

 National Highways Infra Trust	General Conditions of Contract	Doc No.: NHIT/FY25-26/RFP/ Incident Management
--	---------------------------------------	--

Labor price variation shall be based on the **Minimum Wages as issued by the Central Labour Commissioner (CLC), New Delhi**. The escalation will be determined by the percentage change in the minimum wage rates for the relevant labor categories between the base rate and the current rate at the time of execution.

The formula for labor escalation is:

$$P.V(\text{Labor}) = ((\text{Current Minimum Wage} - \text{Base Minimum Wage}) / \text{Base Minimum Wage}) \times (\text{Weight of Labor in Total Cost})$$

22.3.2 Cement Escalation (PC)

Cement price variation will be calculated based on the **Wholesale Price Index (WPI) published by the Reserve Bank of India (RBI) for Ordinary Portland Cement**. The Cement escalation will be determined by the percentage change in the WPI for All commodities used in the project between the base month and the month of execution.

The formula for material escalation is:

$$P.V(\text{Cement}) = ((\text{Current WPI} - \text{Base WPI}) / \text{Base WPI}) \times (\text{Weight of Cement in Total Cost})$$

22.3.3 Steel Escalation (PS)

Steel (steel/components (including strands and cables)) price variation will be calculated based on the **Wholesale Price Index (WPI) published by the Reserve Bank of India (RBI) for Mild Steel – Long Products**. The Steel escalation will be determined by the percentage change in the WPI for All commodities used in the project between the base month and the month of execution.

The formula for material escalation is:

$$P.V(\text{Material}) = ((\text{Current WPI} - \text{Base WPI}) / \text{Base WPI}) \times (\text{Weight of Steel in Total Cost})$$

22.3.4 Bitumen Escalation (PB)

Bitumen price variation will be calculated based on **the official retail price of bitumen at the nearest refinery of IOCL on the first day of the month**. The Bitumen escalation will be determined by the percentage change in the Bitumen prices as issued by IOCL used in the project between the base month and the month of execution.

The formula for material escalation is:

$$P.V(\text{Material}) = ((\text{Current Bitumen Price} - \text{Base Bitumen Price}) / \text{Base Bitumen Price}) \times (\text{Weight of Bitumen in Total Cost})$$

22.3.5 Material Escalation (PM)

Material price variation will be calculated based on the **Wholesale Price Index (WPI) published by the Reserve Bank of India (RBI) for All Commodities**. The material escalation will be determined by the percentage change in the WPI for All commodities used in the project between the base month and the month of execution.

National Highways Infra Trust



General Conditions of Contract

Doc No.: NHIT/FY25-26/RFP/
Incident Management

The formula for material escalation is:

$$P.V(\text{Material}) = ((\text{Current WPI} - \text{Base WPI}) / \text{Base WPI}) \times (\text{Weight of Material in Total Cost})$$

22.3.6 Fuel Escalation (PF)

Fuel price variation shall be based on the **diesel prices at the nearest petrol pump to the project site**, as published by the local authorities or oil companies. The escalation will be determined by the percentage change in the diesel price between the base price at the time of contract signing and the current price during execution.

The formula for fuel escalation is:

$$P.V(\text{Fuel}) = ((\text{Current Diesel Price} - \text{Base Diesel Price}) / \text{Base Diesel Price}) \times (\text{Weight of Fuel in Total Cost})$$

22.3.7 Equipment Escalation (PA)

Equipment price variation shall be based on the **Manufacture of Machinery and Equipment WPI** issued by the Reserve Bank of India (RBI). The escalation will be calculated based on the percentage change in the WPI for machinery and equipment between the base month and the month of execution.

The formula for equipment escalation is:

$$P.V(\text{Equipment}) = ((\text{Current Equipment WPI} - \text{Base Equipment WPI}) / \text{Base Equipment WPI}) \times (\text{Weight of Equipment in Total Cost})$$

22.4 Calculation of Price Variation

The total price variation for the contract will be the sum of the individual price variations for materials, labor, fuel, and equipment, calculated as follows:

$$P.V. = [P.V(\text{Labor}) + P.V(\text{Cement}) + P.V(\text{Steel}) + P.V(\text{Bitumen}) + P.V(\text{Material}) + P.V(\text{Fuel}) + P.V(\text{Equipment})]$$

Where the individual components are calculated based on the relevant indices and their corresponding weights in the contract value.

22.5 Invoice Value for Price Variation

Price variation shall be payable based on the value of work completed and certified during the contract period. The amount of price variation will be calculated on the total invoiced value of the work executed during the contract period (excluding any work completed beyond the contract period or during extensions). The formula for the invoiced amount based on price variation is:

$$P.V. \text{ Amount} = (P.V. \times \text{Invoice Value} \times 0.85)$$

Where:

• P.V. = Price variation (as a percentage)

National Highways Infra Trust

 <p>NHIT National Highways Infra Trust</p>	General Conditions of Contract	Doc No.: NHIT/FY25-26/RFP/ Incident Management
---	---------------------------------------	--

• **Invoice Value = Certified value of the work completed during the contract period.**

22.6 Exclusions for Price Variation

Price variation shall not apply to:

- a) Items for which the rates have been fixed by the Client and are not subject to escalation.
- b) Any variation arising due to changes in taxes, duties, or levies after the contract is signed.
- c) Works executed beyond the contract period, unless extended by mutual agreement.

22.7 Component Weightage

Weightage of each component shall be as defined in the table "Price Variation Component Breakdown" below:

Price Variation Component Breakdown

Component	Earthwork, Granular work, and other works	Bituminous work	Cement Concrete Pavement	Culverts, minor bridges and other structures	Major Bridges and Structures
Labour (PL)	[20%]	[20%]	[20%]	[15%]	[15%]
Cement (PC)	[5%]	Nil	[20%]	[15%]	[15%]
Steel (PS)	Nil	Nil	Nil	[15%]	[20%]
Bitumen (PB)	Nil	[15%]	Nil	Nil	Nil
Fuel and Lubricants (PF)	[10%]	[10%]	[10%]	[10%]	[10%]
Other Materials (PM)	[50%]	[40%]	[35%]	[30%]	[25%]
Plant, Machinery, and Spares (PA)	[15%]	[15%]	[15%]	[15%]	[15%]
Total	100%	100%	100%	100%	100%

22.8 Limitations on Price Variation

The maximum allowable price variation, for any individual item or group of items, shall not exceed **[10%]** of the original contract price. Any variation in excess of this limit shall be subject to mutual agreement between the Client and the Contractor.

22.9 Final Adjustment

At the completion of the work, a final adjustment of the Price Variation will be made based on the actual quantities and costs incurred during the contract period. Any discrepancies, overpayments, or underpayments will be corrected in the final settlement.

23. Substantial Completion and Final Acceptance

23.1 Substantial Completion

23.1.1 Definition

National Highways Infra Trust

	General Conditions of Contract	Doc No.: NHIT/FY25-26/RFP/ Incident Management
---	---------------------------------------	--

Substantial Completion shall be deemed achieved when all contractual obligations related to **road construction, periodic maintenance, routine maintenance, electrical works, and electrical maintenance** have been completed to a stage where the works:

- i. Are fully **operational and fit for their intended purpose**.
- ii. **Comply with all contractual specifications**, statutory requirements, and safety standards.
- iii. Have only **minor Punch List items** remaining, which do not impair the **functionality, safety, or operability** of the works.

23.1.2 Notice of Substantial Completion

The Contractor shall issue a **written Notice of Substantial Completion** to the Client, accompanied by:

- i. **Punch List** – A detailed list of minor pending works or defects.
- ii. **Compliance Certificates** – Certifying that **all civil and electrical installations** meet the required standards and regulations.
- iii. **Test and Inspection Reports** – Demonstrating adherence to contractual and statutory requirements.

23.1.3 Client's Inspection and Certification

- i. The Client shall inspect the works within the timeframe specified in the **Contract Data Sheet (CDS)** and shall either:
 - a) Issue a **Substantial Completion Certificate**, or
 - b) Provide a **written notice** specifying deficiencies to be rectified by the Contractor within a prescribed period.

23.1.4 Contractor's Continuing Obligations

- i. The Contractor remains responsible for completing **all Punch List items** and shall not be relieved of obligations under the **Defect Liability Period (DLP) and Maintenance Provisions** of the contract.

23.2 Final Acceptance

23.2.1 Conditions for Final Acceptance

Final Acceptance shall be granted when the following conditions are met:

- i. **Completion of all Punch List items** to the satisfaction of the Client.
- ii. **Successful completion of the Defect Liability Period (DLP)** as stipulated in the **Special Conditions of Contract (SCC)**.
- iii. **Submission of Final Documentation**, including:
 - a) **Completion Certificates** for road construction, periodic maintenance, routine maintenance, and electrical works.
 - b) **Compliance Certificates** for safety, environmental, and statutory requirements.
 - c) **Warranties and Guarantees** for materials, equipment, and systems used.
 - d) **Operation and Maintenance (O&M) Manuals** where applicable.
 - e) **Final reconciliation of all quantities, variations, and payments**.

23.2.2 Request for Final Acceptance

The Contractor shall formally **request Final Acceptance** in writing, along with supporting documentation proving compliance with all contractual obligations.

23.2.3 Client's Final Inspection and Certification

- i. The Client shall conduct a **Final Inspection** within the timeframe specified in the SCC.
- ii. If the Client is satisfied, a **Final Acceptance Certificate (FAC)** shall be issued, confirming that the Contractor has fully discharged its obligations, except for warranties and ongoing maintenance commitments.

23.2.4 Release of Retention Money and Final Payment

National Highways Infra Trust

	General Conditions of Contract	Doc No.: NHIT/FY25-26/RFP/ Incident Management
---	---------------------------------------	--

- i. The **issuance of the Final Acceptance Certificate** shall be a **precondition** for:
 - a) The **release of retention money**.
 - b) The **final settlement of outstanding payments** to the Contractor under the contract.

23.3 Retention of Rights

The issuance of the **Final Acceptance Certificate** shall not:

23.3.1 Waive the Client's rights to claim against the Contractor for:

- i. **Latent defects** discovered after Final Acceptance.
- ii. **Fraud, wilful misconduct, or gross negligence** that may come to light post-acceptance.

23.3.2 Release the Contractor from:

- i. **Warranty and guarantee obligations** under the contract.
- ii. **Statutory liabilities** that extend beyond the contract period.

23.4 Disputes Regarding Acceptance

- i. Any dispute regarding **Substantial Completion or Final Acceptance** shall be resolved in accordance with **Clause 18 (Dispute Resolution)** of this contract.

23.5 Consequences of Non-Compliance

Failure to achieve **Substantial Completion** or **Final Acceptance** within the stipulated timeframes shall result in:

- i. **Liquidated damages** as specified in the SCC.
- ii. **Applicable penalties** as per the contract.
- iii. **Other contractual remedies**, including the right of the Client to **engage third parties** to complete pending works at the Contractor's cost.

24. Warranty and Maintenance Period

24.1 Warranty Period:

"**Warranty**" shall mean the Contractor's obligation to ensure that all works executed under this Contract, including **Road Construction, Periodic Maintenance, Routine Maintenance, Electrical Works, and Electrical Maintenance**, comply with the prescribed technical specifications, contractual requirements, and statutory standards for the duration of the **Warranty Period**.

The Contractor shall be responsible for rectifying, at no additional cost to the Client, any defects arising from **faulty materials, poor workmanship, design deficiencies, or non-compliance with contractual obligations**, as identified within the **Warranty Period**.

The Warranty Period shall be independent of and in addition to the Defects Liability Period (DLP). The DLP is a defined post-completion phase during which the Contractor remains obligated to rectify defects notified by the Client before the issuance of the Final Acceptance Certificate. The expiry of the DLP shall not relieve the Contractor from its obligations under the Warranty Period, which shall extend beyond the DLP to ensure the long-term durability, functionality, and compliance of the executed works as per the terms of this Contract.

24.1.1 Scope of Warranty

The Contractor shall provide a warranty for all **new construction works, periodic maintenance, routine maintenance, and electrical works** for a period specified in the **Special Conditions of Contract (SCC)**. The warranty period shall commence from the date of the **Final Acceptance Certificate** issued by the Client.

24.1.2 Warranty Obligations for Different Works

	Page 54 of 73	
--	---------------	--

National Highways Infra Trust

 National Highways Infra Trust	General Conditions of Contract	Doc No.: NHIT/FY25-26/RFP/ Incident Management
--	---------------------------------------	--

The Contractor shall be responsible for **repairing, replacing, or rectifying** any defects arising due to **faulty materials, substandard workmanship, or design deficiencies** within the warranty period. The warranty coverage shall include:

i. New Road Construction:

- a. Structural integrity of pavement layers, including subgrade, GSB, WMM, DBM, BC, PQC, and shoulders.
- b. Bridges, culverts, embankments, and retaining structures.
- c. Roadside infrastructure, including crash barriers, pedestrian facilities, and signage.

ii. Periodic Maintenance Works:

- a. Overlay works, resurfacing, micro surfacing, and rejuvenation treatments.
- b. Crack sealing and surface treatments.
- c. Drainage system rehabilitation.

iii. Routine Maintenance Works:

- a. Pothole patching, crack repairs, and road markings.
- b. Cleaning and upkeep of shoulders, medians, and embankments.

iv. Electrical Works:

- a. Street lighting, transformers, feeder panels, and cabling systems.
- b. Power supply infrastructure and associated electrical components.

24.1.3 Coverage and Responsibility

- a. The Contractor shall **rectify all defects at no additional cost** to the Client, including labor, materials, and execution.
- b. If a rectified defect reoccurs within the warranty period, the warranty for that section shall be extended.
- c. Any **failure affecting road safety shall be treated as an emergency and rectified immediately.**

24.2 Maintenance Period

24.2.1 Duration & Scope

Following the completion of the **Warranty Period**, the Contractor shall undertake maintenance responsibilities for a period specified in the **Contract Data Sheet (referred to as the "Maintenance Period")**.

The Contractor shall be responsible for:

- a. **Ensuring the durability and continued serviceability** of the constructed works.
- b. **Periodic inspections and preventive maintenance** of roads, drainage, and electrical systems.
- c. **Immediate rectification of defects identified during inspections or reported by the Client.**

24.2.2 Maintenance Responsibilities

During the Maintenance Period, the Contractor shall:

- i. **Conduct periodic inspections** for early detection of defects.
- ii. **Ensure timely interventions** to prevent deterioration of road surfaces and electrical systems.
- iii. **Maintain an adequate workforce, materials, and equipment** for all maintenance activities.

24.3 Defect Rectifications During Warranty and Maintenance Period

	Page 55 of 73	
--	---------------	--

National Highways Infra Trust

 <p>NHIT National Highways Infra Trust</p>	General Conditions of Contract	Doc No.: NHIT/FY25-26/RFP/ Incident Management
---	---------------------------------------	--

24.3.1 Responsibilities During Warranty Period

- i. The Client shall notify the Contractor in writing of any defects. The Contractor shall rectify them **within the response time defined in the SCC.**
- ii. If a **rectified defect reoccurs within the Warranty Period**, the Contractor shall extend the **warranty obligations** for that section **at no additional cost** to the Client.
- iii. **Failure to rectify defects within the stipulated timeline will result in penalties**, as per Clause **15 (Penalties for Non-Compliance).**
- iv. **Post-completion monitoring of rectified defects shall be undertaken as per Clause 28.4 (Post-Completion Monitoring and Extended Responsibility).**

24.3.2 Responsibilities During Maintenance Period

- i. Any defects identified during the **Maintenance Period** must be attended to promptly, following the maintenance schedule in the **SCC.**
- ii. **Recurring failures due to substandard repairs will lead to additional penalties**, as per **Clause 15 (Penalties for Non-Compliance).**
- iii. **All defect rectifications shall be performed in accordance with Clause 28.3 (Defect Rectification and Performance Assurance).**

24.3.3 Liability for Non-Performance of Warranty & Maintenance Obligations

- i. If the Contractor **fails to rectify defects within the stipulated timeline**, the Client shall have the right to:
 - a) Undertake the necessary rectifications at the Contractor's risk and cost.
 - b) Recover the expenses incurred by deducting the amount from payments due or the performance security.
- ii. The Contractor shall bear **all costs for repairing or replacing defective work** and any **damage caused to third parties due to non-compliance.**

24.3.4 Extended Warranty or Maintenance Period

- i. If defects persist beyond the original Warranty or Maintenance Period, an **extension of obligations may be required** under the same terms and conditions.
- ii. The extension shall be **subject to mutual agreement** between the Client and the Contractor.
- iii. **For extended responsibilities related to defect rectifications, Clause 28.3 shall apply.**

24.3.5 Performance Testing & Inspections

- i. During the **Warranty and Maintenance Period**, the Contractor shall conduct **performance testing and inspections** to ensure compliance with **MoRTH and IRC standards.**
- ii. The Client may require additional testing based on **statutory requirements** or performance benchmarks.

24.3.6 Final Inspection & Completion of Maintenance Period

- i. At the end of the **Maintenance Period**, the Contractor shall formally notify the Client and request a **Final Inspection.**
- ii. The Client shall conduct a **final performance inspection** to verify compliance with all maintenance obligations.

National Highways Infra Trust

 <p>NHIT National Highways Infra Trust</p>	General Conditions of Contract	Doc No.: NHIT/FY25-26/RFP/ Incident Management
---	---------------------------------------	--

- iii. If all contractual conditions are met, the Client shall issue a **Certificate of Completion for the Maintenance Period.**
- iv. **Any outstanding defect rectifications and post-completion responsibilities shall be handled as per Clause 28.4.**

25. Site Management and Supervision

25.1 Site Management and Supervision Requirements:

25.1.1 The Contractor shall be responsible for the effective management, supervision, and control of the worksite throughout the duration of the Contract, ensuring that all work is carried out in compliance with the approved plans, specifications, and relevant statutory and regulatory requirements.

25.1.2 The Contractor shall provide all necessary site management and supervision staff to ensure the timely, efficient, and safe execution of the works. The Contractor's site management team shall include suitably qualified engineers and personnel, each possessing the necessary qualifications, experience, and competence relevant to the specific tasks they are assigned.

25.2 Qualification of Engineers and Personnel:

25.2.1 The Contractor shall submit the qualifications, certifications, and experience details of all key personnel assigned to the project, including engineers, supervisors, and safety officers, for approval by the Client prior to commencement of work.

25.2.2 All engineers and supervisors shall hold qualifications and experience that are consistent with industry standards, and the Client reserves the right to reject any personnel deemed unqualified or inadequate for their assigned tasks.

25.3 Organization Chart and Manpower Deployment:

25.3.1 The Contractor shall submit an updated Organization Chart detailing the project's key personnel and their responsibilities, along with a manpower deployment plan, to the Client for approval.

25.3.2 The Contractor shall ensure that the necessary number and skill levels of personnel are deployed at the worksite throughout the project. The manpower plan shall include, but not be limited to, civil engineers, electrical engineers, safety officers, supervisors, foremen, and labourers. The Contractor shall update the manpower deployment plan regularly to reflect any changes in staffing or work requirements.

25.4 Construction Schedule and Work Monitoring:

25.4.1 The Contractor shall submit a detailed construction schedule, including milestones and timelines, for Client approval prior to the commencement of work. This schedule shall outline the planned sequence of work, dependencies, and estimated completion dates for each phase of the project.

25.4.2 The construction schedule shall be regularly updated and adjusted to reflect actual progress and any changes to the work scope, delays, or other factors affecting the timeline. The Contractor shall notify the Client in writing of any deviations from the approved schedule.

25.5 Progress Reporting and Documentation:

National Highways Infra Trust

	General Conditions of Contract	Doc No.: NHIT/FY25-26/RFP/ Incident Management
---	---------------------------------------	--

25.5.1 The Contractor shall provide daily, weekly, and monthly progress reports to the Client. These reports shall detail the progress of all ongoing work, including work completed, work planned for the next reporting period, any issues encountered, and actions taken to address them.

25.5.2 The reports shall include:

- a) Daily Progress Reports (to include manpower deployed, equipment used, work accomplished, and any issues encountered).
- b) Weekly Progress Reports (to provide a summary of work completed, pending, and planned tasks, along with any delays or obstacles).
- c) Monthly Progress Reports (including a detailed overview of overall project progress, challenges, and mitigation measures).

25.5.3 The reports must be submitted in the format approved by the Client, and shall be accompanied by photographs or other relevant documentation as necessary to clearly demonstrate progress.

25.6 Supervision and Site Inspections:

25.6.1 The Contractor shall ensure that qualified engineers and supervisors are present on-site at all times during the execution of the works, supervising the quality and progress of the work.

25.6.2 The Contractor shall provide the Client with access to the site at all times for the purpose of inspecting, reviewing, and evaluating the work. The Client may conduct periodic or surprise inspections to ensure compliance with the contract specifications and work quality standards.

25.7 Coordination and Collaboration:

25.7.1 The Contractor shall coordinate all activities on-site, including subcontractors, suppliers, and any third-party entities involved in the project, to ensure smooth, uninterrupted work flow and adherence to the project schedule.

25.7.2 The Contractor shall maintain effective communication with the Client's designated project manager and provide all necessary support for coordination and monitoring of work progress.

25.8 Site Safety and Compliance:

25.8.1 The Contractor shall ensure that all work is performed in compliance with the applicable health, safety, and environmental regulations. A qualified Safety Officer shall be assigned to monitor compliance with safety standards on the site.

25.8.2 The Contractor shall submit safety plans, emergency procedures, and risk assessments for approval before commencement of any work. Regular safety audits and reviews shall be conducted as part of the project supervision.

25.9 Penalties for Non-Compliance:

25.9.1 Failure to comply with the site management and supervision requirements, including the submission of the Organization Chart, manpower plan, construction schedule, progress reports, or failure to ensure appropriate supervision, shall result in penalties as outlined in the Special Conditions of Contract (SCC).

25.9.2 Non-compliance with safety standards, manpower shortages, or inadequate supervision will be subject to corrective actions, including possible suspension of work until compliance is achieved.

26. Indemnity and Liability

26.1 Contractor's Liability for Faults and Failures:

National Highways Infra Trust

 <p>NHIT National Highways Infra Trust</p>	General Conditions of Contract	Doc No.: NHIT/FY25-26/RFP/ Incident Management
---	---------------------------------------	--

The Contractor shall be liable for all costs, losses, or damages incurred by the Client arising from:

26.1.1 Defective Work: Any defects in workmanship, materials, or designs that are not in accordance with the agreed specifications or industry standards.

26.1.2 Non-Compliance: Any failure by the Contractor to comply with the terms of the contract, including delays, substandard work, or failure to meet performance standards.

26.1.3 Failure to Meet Milestones: If the Contractor's fault causes delay or non-performance that affects the overall project timeline, the Contractor shall be liable for additional costs or damages suffered by the Client due to such delays.

26.2 Recovery of Costs:

26.2.1 The Client has the right to recover any costs incurred due to the Contractor's failures or delays, which include but are not limited to:

26.2.1.1 Costs for rework or rectification of defective work.

26.2.1.2 Additional costs for resources required to mitigate the impact of the Contractor's failure.

26.2.1.3 Costs for hiring third-party services, consultants, or experts to address the consequences of the Contractor's shortcomings.

26.2.2 The Client may deduct these costs from any pending payments due to the Contractor, including retention amounts.

26.3 Indemnity:

26.3.1 The Contractor shall indemnify and hold the Client harmless against all claims, losses, damages, liabilities, or expenses arising from:

26.3.1.1 Breach of the contract by the Contractor.

26.3.1.2 Negligence or failure to act in accordance with statutory and regulatory requirements.

26.3.1.3 Any third-party claims related to defective work or performance under the contract.

26.4 Exclusion of Certain Liabilities:

26.4.1 This clause shall not apply to liabilities arising from Force Majeure events, or those outside the Contractor's control, unless expressly stated in the contract.

- i. The Contractor's liability is also subject to the terms of the **Force Majeure and Risk Allocation** clauses, where applicable.

26.5 Documentation and Notices:

26.5.1 The Client shall notify the Contractor in writing of any defects or costs incurred due to the Contractor's fault within a specified period after discovery.

26.5.2 The Contractor shall promptly investigate and take corrective actions at their own cost, or the Client may take remedial measures if the Contractor fails to act within a reasonable timeframe.

27. Reporting and Documentation

27.1 General Reporting Requirements:

The Contractor shall maintain **accurate, up-to-date, and detailed records** of all activities, progress, and events related to the execution of **Road Construction, Periodic Maintenance, Routine Maintenance, and Electrical Works & Maintenance**. These records shall include, but are not limited to:

- i. **Daily progress reports** covering work completed, material consumption, deployed manpower, and equipment usage.

National Highways Infra Trust

 <small>National Highways Infra Trust</small>	General Conditions of Contract	Doc No.: NHIT/FY25-26/RFP/ Incident Management
---	---------------------------------------	--

- ii. **Quality control reports** including test results, material inspections, and compliance with MoRTH, IRC, and IS standards.
- iii. **Maintenance logs** documenting all periodic and routine maintenance activities, including pothole repairs, resurfacing, drainage cleaning, and roadside infrastructure upkeep.
- iv. **Electrical maintenance records** for streetlights, transformers, feeder panels, and high-mast lights, including uptime tracking and fault rectification timelines.
- v. **Safety and environmental compliance reports**, detailing adherence to HSE standards, traffic management measures, and environmental mitigation actions.
- vi. **Emergency repair reports** specifying the nature of the incident, response time, and remedial actions taken.

The Contractor shall also maintain and submit detailed records of defect rectifications, including recurrence tracking, corrective actions taken, and post-completion monitoring reports, as required under Clause 28.5 (Documentation & Record-Keeping)

The Contractor shall ensure that all documentation is **properly organized, legible, and readily available** for inspection by the Client or its authorized representatives at any time. Reports shall be submitted **as per the prescribed formats and timelines** defined in the contract.

All reports and documentation shall be submitted in accordance with the formats, timelines, and instructions provided by the Client. The Contractor shall ensure the timely and correct submission of the required documentation without delay.

27.2 Types of Reports:

27.2.1 Daily Progress Reports:

- i. The Contractor shall submit daily progress reports detailing the work performed, manpower deployed, equipment utilized, and any challenges encountered on-site. These reports shall also include information on material consumption, quality control activities, and safety compliance. The reports should clearly identify any work delays, hindrances, or deviations from the scheduled activities, as well as the corrective actions taken.
- ii. The daily progress report shall be submitted to the Client within [24] hours from the end of each working day.

27.2.2 Weekly Progress Reports:

- i. The Contractor shall provide a weekly progress report summarizing the work accomplished, work planned for the following week, and any ongoing or anticipated challenges or risks. This report shall also include updated details of the work schedule, manpower, equipment, and materials usage, along with key project metrics and any changes to the approved schedule or scope.
- ii. The weekly report shall be submitted to the Client no later than [every Friday] for the preceding week.

27.2.3 Monthly Progress Reports:

- i. A detailed monthly progress report shall be submitted, covering all aspects of the project's progress, including completed milestones, ongoing works, deviations from the schedule, safety performance, and material and equipment status. The report shall highlight any issues impacting project completion and propose corrective actions.
- ii. This report shall be submitted to the Client within [5] working days after the end of each month.

27.3 Document Submission Requirements:

27.3.1 Work-Related Documentation:

	Page 60 of 73	
--	---------------	--

National Highways Infra Trust

	General Conditions of Contract	Doc No.: NHIT/FY25-26/RFP/ Incident Management
---	---------------------------------------	--

- i. The Contractor shall submit the following documents along with their respective reports or as required by the Client:
 - a. Updated construction schedule and progress charts.
 - b. Record of materials used, including delivery notes, material certifications, and inspection reports.
 - c. Details of equipment usage and maintenance logs.
 - d. Work inspection reports and any testing or quality control documentation.
 - e. Photos or drawings illustrating the progress of key works or any issues encountered.
 - f. Correspondence, meeting minutes, and any other relevant documents that affect the progress of the work.

27.3.2 Statutory Compliance Documents:

- i. The Contractor shall also submit all statutory compliance documentation in line with legal and regulatory requirements, including:
 - a. Proof of statutory licenses, permits, and approvals.
 - b. Safety inspection and audit reports.
 - c. Workers' compensation and insurance certificates.
 - d. Records of labor and safety audits, if applicable.
 - e. Environmental compliance certificates, if applicable.
 - f. Health, safety, and environmental incident reports, if applicable.

27.4 Documentation for Payment Claims:

27.4.1 Submission Requirements

The Contractor shall submit **all required supporting documentation** along with each payment claim, as stipulated in **Clause 14 (Payment Terms and Conditions)**. The submitted documentation must be **complete, accurate, and verifiable**, ensuring compliance with contractual, statutory, and quality standards.

27.4.2 Mandatory Supporting Documents

Each payment claim shall be accompanied by the following:

- i. **Detailed Tax Invoices**
 - a. Clearly itemized **breakdown of work completed**, including road works, periodic maintenance, routine maintenance, electrical works, and electrical maintenance.
 - b. **GST-compliant format**, where applicable.
- ii. **Certification of Work Completion**
 - a. **Site Supervisor's or Client's Representative's Certification**, confirming satisfactory completion of the claimed work.
 - b. **Measurement Books (MBs) and Work Logs** duly signed and authenticated.
- iii. **Inspection and Test Reports**
 - a. **Quality control and assurance reports**, including material and workmanship compliance records.
 - b. **Inspection and certification reports** for specialized works such as **electrical installations and roadwork quality assessments**.
- iv. **Labor Deployment Records**
 - a. **Signed timesheets**, specifying workforce details, shift durations, and site attendance.
 - b. **Deployment logs** for skilled and unskilled labor.
- v. **Material Delivery and Receipt Confirmations**

National Highways Infra Trust

 <p>NHIT National Highways Infra Trust</p>	General Conditions of Contract	Doc No.: NHIT/FY25-26/RFP/ Incident Management
---	---------------------------------------	--

- a. **Supplier delivery challans and invoices**, duly acknowledged by the Client's site representative.
- b. **Material reconciliation statements**, where required.
- vi. **Additional Documentation**
 - a. Any **other document(s) requested by the Client** for verification, including statutory compliance records, safety certifications, and subcontractor invoices, where applicable.

27.4.3 Verification and Approval Process

- i. The **Client shall review and verify** the submitted documents within the timeframe specified in **Clause 14 (Payment Terms and Conditions)**.
- ii. In case of **discrepancies or missing documents**, the Contractor shall provide clarifications or resubmissions within the stipulated period, without affecting the overall payment timeline.

27.4.4 Consequences of Non-Compliance

Failure to submit **complete and accurate** documentation shall result in:

- i. **Withholding or delay of payment** until compliance is achieved.
- ii. Possible **imposition of penalties** or contractual remedies, as per Clause 14.
- iii. Rejection of the payment claim if deficiencies persist beyond the **specified rectification period**.

27.5 Record Keeping and Client Access:

27.5.1 The Contractor shall maintain records of all work performed, materials supplied, and equipment used for the duration of the contract, including any variations or changes to the original scope. All records shall be made available to the Client upon request.

27.5.2 The Client or its representatives shall have the right to review, audit, and copy any of the documentation submitted by the Contractor. The Contractor shall cooperate fully with the Client during such audits and inspections, providing all necessary assistance and documentation.

27.6 Corrective Actions for Non-Compliance:

27.6.1 In the event that the Contractor fails to submit any required reports or documentation in a timely or accurate manner, the Client reserves the right to impose corrective actions, including penalties or suspension of payment, until the required documentation is provided.

27.6.2 If any discrepancies, omissions, or inaccuracies are found in the documentation provided, the Contractor shall promptly correct and resubmit the documentation within [a specified time frame] at no additional cost to the Client.

27.7 Final Documentation:

27.7.1 Upon the completion of the contract, and prior to the final acceptance of the works, the Contractor shall submit all relevant final documentation, including but not limited to:

- a) As-built drawings and final construction reports.
- b) Final certification of work completion and acceptance by the Client.
- c) All warranty documents for materials and equipment installed.
- d) Final test and inspection certificates, if applicable.
- e) Any other documents as stipulated in the Special Conditions of Contract or by the Client.

27.8 Electronic Submission of Documents:

	Page 62 of 73	
--	---------------	--

National Highways Infra Trust

 <p>NHIT National Highways Infra Trust</p>	General Conditions of Contract	Doc No.: NHIT/FY25-26/RFP/ Incident Management
---	---------------------------------------	--

27.8.1 The Contractor is encouraged to submit all reports and documentation electronically, where possible, to facilitate faster processing and easier access. All electronic submissions should be in an acceptable file format, such as PDF, Excel, or Word, as specified by the Client.

27.8.2 In case of hardcopy submission, the Contractor shall provide the necessary number of copies as requested by the Client.

28. Maintenance Responsibilities and Post-Completion Obligations

28.1 Contractor's Obligations for Maintenance Works

The Contractor shall be fully responsible for the **maintenance, upkeep, and operational performance** of all road infrastructure and associated electrical systems. This includes, but is not limited to:

- i. **Pavements, shoulders, and drainage systems**, ensuring structural integrity and unobstructed water flow.
- ii. **Traffic signage, road markings, and safety barriers**, ensuring visibility and compliance with MoRTH and IRC standards.
- iii. **Street lighting, transformers, and electrical systems**, ensuring a minimum **98% operational uptime**.
- iv. **Emergency maintenance response**, including prompt rectification of damages caused by accidents, adverse weather, or unforeseen events.

All maintenance activities shall comply with the **contract specifications, MoRTH guidelines, IRC standards, and relevant statutory regulations**. The Contractor shall ensure **timely rectification of defects, preventive maintenance, and performance monitoring** throughout the contract period.

28.2 Inspection, Monitoring, and Reporting

The Contractor shall conduct **regular inspections and performance evaluations** as per the approved Maintenance Plan, which shall include:

- i. **Daily inspections** for routine maintenance (potholes, cracks, road markings, signage, and lighting).
- ii. **Weekly inspections** for structural elements, including drains, safety barriers, and electrical systems.
- iii. **Monthly inspections** for periodic maintenance planning, material quality checks, and service life assessments.
- iv. **Post-completion monitoring** of rectified works to ensure durability and adherence to quality standards.

Inspection reports shall be maintained and submitted as per Clause 27 (Reporting and Documentation), ensuring traceability of all maintenance activities. Any defects identified shall be rectified **within the prescribed response times**, failing which penalties shall be imposed as per Clause 15 (Performance Standards and Penalties).

28.3 Defect Rectification and Performance Assurance

- i. The Contractor shall **immediately address any reported defects or failures** within the contractual response time.
- ii. All rectifications, repairs, and replacements **shall be executed at the Contractor's cost** during the maintenance period.

National Highways Infra Trust

	General Conditions of Contract	Doc No.: NHIT/FY25-26/RFP/ Incident Management
---	---------------------------------------	--

- iii. If rectification delays exceed the **maximum allowable limit**, the Client reserves the right to undertake corrective actions at the **Contractor's risk and cost**, with recovery through penalties or performance security deductions.
- iv. If a defect reappears in the same location within the maintenance period due to poor workmanship or substandard materials, the Contractor shall be responsible for rework at no additional cost to the Client.
- v. Repeated failures in rectified sections will result in extended performance obligations and additional penalties, as per Clause 15.4.2.

28.4 Post-Completion Monitoring and Extended Responsibility

- i. After the completion of **any repair, resurfacing, or structural rectification**, the Contractor shall **monitor the performance** of the restored section for a period as defined in the contract.
- ii. If failures occur within this monitoring period due to **poor workmanship, substandard materials, or improper execution**, the Contractor shall be obligated to **rework at no additional cost** to the Client.
- iii. The Client or its authorized representative shall have the right to **inspect and assess** the performance of all maintenance works and may impose corrective measures if performance benchmarks are not met.

28.5 Documentation and Record-Keeping

The Contractor shall **maintain detailed records** of all maintenance activities, inspections, defect rectifications, and post-completion monitoring. These records shall include:

- i. **Daily maintenance logs** with details of work completed, manpower deployed, and materials used.
- ii. **Inspection reports and defect records**, specifying issues identified, response times, and corrective measures taken.
- iii. **Compliance reports** to verify adherence to MoRTH, IRC, and contractual quality standards.

All reports shall be **submitted to the Client** in accordance with Clause 27 (Reporting and Documentation) and made available for audits or verification at any time.

29. Defects Liability Period (DLP)

29.1 Definition and Scope

The **Defects Liability Period (DLP)** shall commence from the date of **Substantial Completion** and the issuance of the **Certificate of Substantial Completion** by the Client. During this period, the Contractor shall be responsible for identifying and rectifying any defects, deficiencies, or non-conformities in the works related to **road construction, periodic maintenance, routine maintenance, electrical works, and electrical maintenance**. These defects may arise due to **faulty materials, poor workmanship, or non-compliance** with the contract specifications, approved designs, or relevant standards. The Contractor shall, at its own cost, rectify such defects within the timeframe stipulated by the Client, ensuring that the works meet the required functional, structural, and safety standards. Any failure to address defects within the specified period may result in the Client undertaking the necessary rectifications at the Contractor's risk and expense. The issuance of the **Final Acceptance Certificate** shall be subject to the satisfactory completion of all remedial works.

National Highways Infra Trust

	General Conditions of Contract	Doc No.: NHIT/FY25-26/RFP/ Incident Management
---	---------------------------------------	--

29.2 Rectification of Defects

The Contractor shall promptly investigate and rectify any defects or deficiencies identified by the Client during the **Defects Liability Period (DLP)** within the timeframe specified in the Contract or as instructed by the Client. The rectification work shall be carried out in compliance with the contract specifications, applicable standards, and safety requirements, ensuring that the works maintain their structural integrity, functionality, and operational efficiency. All costs associated with defect rectification, including materials, labor, equipment, and any necessary rework, shall be borne entirely by the Contractor. In the event of failure to rectify defects within the stipulated timeframe, the Client reserves the right to impose penalties as per **Clause 15 (Performance Standards and Penalties)** or undertake the rectification work at the Contractor's risk and expense. The Contractor shall also ensure that any remedial work does not disrupt the ongoing operations or compromise the safety of road users and site personnel.

29.3 Inspection During DLP

During the **Defects Liability Period (DLP)**, the Client or its authorized representative shall have the unrestricted right to inspect the completed works at any time to assess their performance, structural integrity, and compliance with contractual requirements. The Contractor shall facilitate such inspections by providing full access to all relevant areas, documentation, and personnel necessary for a thorough evaluation. Any defects, deficiencies, or non-conformities identified during these inspections shall be formally notified to the Contractor in writing, specifying the nature and extent of the required remedial actions. The Contractor shall undertake corrective measures without delay, ensuring that all defects are rectified to the satisfaction of the Client. Failure to address the notified defects within the prescribed timeframe shall attract penalties as per **Clause 15 (Performance Standards and Penalties)**, and the Client may undertake the necessary rectifications at the Contractor's cost and risk.

29.4 Maintenance During DLP

The Contractor shall ensure that all components related to road construction, periodic maintenance, routine maintenance, electrical works, and electrical maintenance— including road pavements, drainage systems, street lighting, signage, and other associated civil and electrical infrastructure— are maintained in a fully functional and compliant state throughout the Defects Liability Period (DLP). The Contractor shall conduct routine inspections and undertake necessary maintenance activities in accordance with the standards specified in the Contract, MoRTH specifications, and IRC guidelines. Any deterioration, structural failures, electrical malfunctions, or deficiencies identified during this period shall be rectified by the Contractor at its own cost within the timeframe specified in the Contract or as directed by the Client. Non-compliance with maintenance obligations or delays in rectification shall attract penalties as per Clause 15 (Performance Standards and Penalties), and the Client reserves the right to undertake necessary corrective actions at the Contractor's expense.

29.5 Final Inspection and Handover

Before the expiry of the Defects Liability Period (DLP), the Contractor shall formally notify the Client of the readiness for a final inspection. The Client or its authorized representative shall conduct a thorough inspection of all works related to road construction, periodic maintenance, routine maintenance, electrical works, and electrical maintenance, including road pavements, drainage systems, street lighting, signage, and other associated civil and electrical infrastructure. The inspection shall verify that all identified defects, deficiencies, and

National Highways Infra Trust

 National Highways Infra Trust	General Conditions of Contract	Doc No.: NHIT/FY25-26/RFP/ Incident Management
--	---------------------------------------	--

non-conformities have been rectified as per the contractual requirements, MoRTH specifications, and IRC guidelines. If the works are found to be in compliance and satisfactory, the Client shall issue the Final Acceptance Certificate, formally concluding the DLP. In case of any outstanding deficiencies, the Contractor shall be required to address them within the stipulated timeframe before the certificate is issued.

29.6 Extension of DLP

If any defects, deficiencies, or non-conformities related to road construction, periodic maintenance, routine maintenance, electrical works, or electrical maintenance remain unresolved at the expiry of the Defects Liability Period (DLP), the DLP shall be automatically extended until all such defects have been satisfactorily rectified and certified by the Client. The Contractor shall remain fully responsible for rectifying these defects at its own cost, ensuring compliance with the contractual requirements, MoRTH specifications, and IRC guidelines. The extended DLP shall continue until the Client formally certifies that all outstanding defects have been addressed to its satisfaction. Any failure to rectify defects within the extended period may result in penalties, deductions, or other remedies as stipulated in the contract.

29.7 Retention Release

The release of retention money or any portion thereof, held as a performance guarantee during the Defects Liability Period (DLP), shall be contingent upon the satisfactory rectification of all defects, deficiencies, and non-conformities related to road construction, periodic maintenance, routine maintenance, electrical works, and electrical maintenance. Upon successful completion of the final inspection and verification that all rectifications have been carried out in accordance with the contract, MoRTH specifications, and IRC guidelines, the Client shall issue the Final Acceptance Certificate. Only upon issuance of this certificate shall the retention money be released to the Contractor. Any pending defects at the time of DLP expiry may lead to a proportional withholding of retention money until all outstanding issues are resolved.

29.8 Duration of DLP

The Defects Liability Period (DLP) shall be **twelve (12) months** or as mentioned in **Contract Data Sheet**, from the date of issuance of the Certificate of Substantial Completion by the Client, unless extended under **Clause 29.6**.

Exclusions

The Contractor shall not be liable for defects arising due to normal wear and tear, misuse, or acts of God as defined under **Clause 19, Force Majeure**, unless otherwise specified in the Contract.

30. Liquidated Damages

30.1 Applicability

The Contractor acknowledges that the **timely and satisfactory execution of Road Construction, Periodic Maintenance, Routine Maintenance, Electrical Works, and Electrical Maintenance** is critical to the Client's operations. Any **failure to meet the performance standards, contractual timelines, or obligations** as specified in this Contract shall result in the imposition of **Liquidated Damages (LD)** as **compensation for losses, operational disruptions, or inconvenience caused to the Client**.

National Highways Infra Trust

	General Conditions of Contract	Doc No.: NHIT/FY25-26/RFP/ Incident Management
---	---------------------------------------	--

30.2 Trigger for Liquidated Damages

Liquidated Damages shall become applicable in the following scenarios:

- a) Delayed commencement or completion of any scheduled maintenance activities.
- b) Non-compliance with response times for emergency repairs or incident management.
- c) Failure to maintain performance standards as per **Clause 28**, Maintenance and Performance.
- d) Repeated non-rectification of defects within stipulated time frames during the Defects Liability Period (DLP).

30.3 Rate of Liquidated Damages

The LD rate shall be calculated as a percentage of the Contract Value or the specific milestone value, as detailed in the **Contract Data Sheet**. The total LD shall not exceed the maximum cap, **10% of the Contract Value**, unless otherwise specified in the Contract Data Sheet.

30.4 Computation and Deduction

The Liquidated Damages shall be calculated on a pro-rata basis for delays or deficiencies, as applicable, and shall be deducted from the Contractor's interim payments, retention money, or any other dues payable under the Contract.

30.5 Exemptions

No Liquidated Damages shall apply if the delay or non-compliance is solely attributable to:

- a) Force Majeure events, as defined in **Clause 19**.
- b) Written instructions or approvals awaited from the Client beyond the stipulated period.

30.6 Additional Penalties for Chronic Non-Performance

In cases of persistent or willful non-performance by the Contractor, as determined by the Client, the Liquidated Damages may be supplemented with penalties, termination, or other remedies provided under this Contract.

30.7 Non-Exclusivity of LD

The imposition of Liquidated Damages shall not preclude the Client from seeking other remedies, including termination of the Contract or claims for actual damages, where applicable.

30.8 Acknowledgement

The Contractor agrees that the Liquidated Damages are a genuine pre-estimate of the loss likely to be suffered by the Client and do not constitute a penalty under applicable laws.

31. Notices and Communications

31.1 Mode of Communication:

All notices, instructions, approvals, requests, and other communications required or permitted under this contract shall be in writing and delivered through one of the following means:

- a) Registered post or courier to the designated addresses of the parties.
- b) Email communication to the designated official email addresses provided by the parties, provided that such emails are acknowledged by the recipient.

National Highways Infra Trust

	General Conditions of Contract	Doc No.: NHIT/FY25-26/RFP/ Incident Management
---	---------------------------------------	--

31.2 Designated Contact Details:

Each party shall provide and maintain updated contact details, including physical address, email address, and phone number, for all official communications. Notices sent to these addresses shall be deemed to have been duly served.

31.3 Effective Date of Notices:

Notices shall be deemed to have been received:

- a) If delivered by registered post or courier, on the date of actual delivery or acknowledgment of receipt.
- b) If sent by email, on the date of acknowledgment by the recipient, or, if no acknowledgment is received, within 48 hours of dispatch, provided no error or failure message is received.

31.4 Change of Address or Contact Details:

Either party may change its designated contact details by giving written notice to the other party. Such changes shall become effective five (5) business days after receipt of the notice.

31.5 Language of Communication:

All notices and communications under this contract shall be in English unless otherwise specified in the Special Conditions of Contract.

31.6 Binding Nature of Communications:

All instructions, notices, and approvals issued by the Client under this clause shall be binding on the Contractor. Any queries or clarifications from the Contractor must be sought in writing within the stipulated time frame specified in the contract.

31.7 Service of Legal Notices:

Legal notices related to the contract shall be served to the respective registered office addresses of the parties and marked "For the Attention of Legal Counsel."

32. Confidentiality and Non-Disclosure

32.1 Confidential Information:

All information, data, reports, drawings, documents, trade secrets, technical specifications, and other materials, whether written, verbal, or electronic, disclosed by either party during the performance of this contract shall be considered confidential and proprietary ("Confidential Information").

32.2 Obligations of the Contractor:

The Contractor agrees to:

- a) Use Confidential Information solely for the purpose of fulfilling its obligations under this contract.
- b) Not disclose or permit the disclosure of Confidential Information to any third party without the prior written consent of the Client, except as required by law.
- c) Protect Confidential Information with the same degree of care used to safeguard its own confidential and proprietary information but no less than reasonable care.

32.3 Permitted Disclosures:

The Contractor may disclose Confidential Information to:

- a) Employees or subcontractors who need access to such information to perform the contract, provided they are bound by confidentiality obligations no less restrictive than those in this clause.
- b) Government authorities or regulatory bodies, as required by applicable law, after notifying the Client in writing (unless prohibited by law).

32.4 Exclusions from Confidentiality:

The obligations under this clause shall not apply to information that:

National Highways Infra Trust

	General Conditions of Contract	Doc No.: NHIT/FY25-26/RFP/ Incident Management
---	---------------------------------------	--

- a) Is or becomes publicly available through no breach of this agreement.
- b) Was already in the possession of the receiving party without restriction before its disclosure.
- c) Is independently developed by the receiving party without use of or reference to the Client's Confidential Information.
- d) Is lawfully disclosed to the receiving party by a third party without restriction on disclosure.

32.5 Return or Destruction of Information:

Upon the completion, termination, or expiration of this contract, or upon the Client's written request, the Contractor shall return or destroy all copies of the Client's Confidential Information and provide written confirmation of such destruction.

32.6 Duration of Confidentiality Obligations:

The confidentiality obligations under this clause shall survive the termination or expiration of this contract for a period of **five (5) years** unless otherwise agreed in writing.

32.7 Remedies for Breach:

In the event of a breach or threatened breach of this clause, the Client shall be entitled to seek equitable relief, including but not limited to an injunction, in addition to any other remedies available under law or equity.

33. Bank Guarantee Formats

Provision of Bank Guarantee Formats:

33.1 Bank Guarantee Formats:

33.1.1 The Client shall provide the Contractor with the required formats for **Bank Guarantees** as per the terms and conditions stipulated in the Contract, including but not limited to:

- i. Performance Bank Guarantee
- ii. Advance Payment Bank Guarantee
- iii. Retention Money Bank Guarantee
- iv. Security Deposit Bank Guarantee, if applicable.

33.2 Availability of Formats:

33.2.1 The Contractor shall be provided with the Bank Guarantee formats within **[7] days** from the date of contract execution or from the date of any event that triggers the requirement for a Bank Guarantee (e.g., Advance Payment, Performance Guarantee).

33.2.2 These formats shall be made available either through the following means: - Directly from the Client's Contract Administrator or Authorized Representative. - Via the Client's designated electronic document management system (if applicable), accessible to the Contractor.

33.2.3 Request for Formats: In the event the Contractor does not receive the Bank Guarantee formats as specified, the Contractor may request the required format(s) in writing. The Client shall make the necessary formats available to the Contractor within **[7] days** of receiving such a request.

33.3 Compliance with Format:

The Contractor shall ensure that the Bank Guarantees are furnished in strict accordance with the formats provided by the Client. Any deviations from the prescribed format shall be subject to the Client's approval.

33.4 Submission of Bank Guarantees:

National Highways Infra Trust

	General Conditions of Contract	Doc No.: NHIT/FY25-26/RFP/ Incident Management
---	---------------------------------------	--

The Contractor shall submit the original Bank Guarantees to the Client at the appropriate stages, as per the terms of the Contract, and ensure that they are valid for the required period as per the contractual obligations.

33.5 Costs of Bank Guarantees:

All costs, charges, and fees related to the issuance and renewal of the Bank Guarantees shall be borne by the Contractor unless otherwise agreed by the parties in writing.

34. Limitation of Liability

The liability of the Contractor under this Agreement, whether arising from breach of contract, negligence, or any other cause, shall not exceed the total contract value or the amount recoverable under applicable insurance policies, whichever is higher, except in cases of gross negligence, wilful misconduct, or fraud. The Contractor shall not be held liable for indirect, incidental, or consequential damages, including but not limited to loss of profit, revenue, or anticipated savings, unless expressly stated otherwise in this Agreement or applicable law.

The Client's liability under this Agreement is limited to payment for works / services rendered and duly certified in accordance with the terms of this Contract. In no case shall either party be liable for claims arising from delays, disruptions, or failures resulting from events classified as Force Majeure, as defined under **Clause 19**.

This limitation shall not affect the Contractor's obligations related to indemnities, intellectual property, warranties, or the rectification of defects as outlined in this Agreement.

35. Annexures and Appendices

The following annexures and appendices form an integral part of this Contract and shall be referred to for detailed guidelines, specifications, and requirements applicable to the Road Maintenance Works:

a) **Bill of Quantities (BOQ)**

This annexure includes the detailed schedule of quantities, unit rates, and cost estimates for all items of work covered under the Contract. The BOQ shall form the basis for interim and final payments, subject to adjustments as per the Contract terms.

b) **Specifications for Materials and Equipment**

This document provides the technical specifications for all materials and equipment to be supplied and utilized in the execution of the works, as per the latest MoRTH specifications, IRC standards, and other applicable codes. Compliance with these specifications is mandatory.

c) **Work Orders and Sample Forms**

Standardized templates for issuing work orders, recording daily progress, and maintaining site records are provided. These shall be used for proper documentation and record-keeping during the execution of the Contract.

d) **Inspection and Maintenance Checklists**

Comprehensive checklists detailing the procedures for inspections, periodic maintenance activities, and quality assurance measures are included to ensure compliance with performance standards.

e) **Safety Standards and Procedures**

This appendix outlines the safety protocols, emergency response plans, and mandatory compliance measures to ensure the health and safety of workers and the general public during the execution of works.

National Highways Infra Trust

	General Conditions of Contract	Doc No.: NHIT/FY25-26/RFP/ Incident Management
---	---------------------------------------	--

f) **Bank Guarantees**

This annexure includes the formats for bank guarantees required under the Contract, such as Performance Bank Guarantee, Advance Payment Guarantee, and Retention Money Guarantee. The Contractor shall ensure that all bank guarantees are submitted in the approved format and within the stipulated timelines as specified in the Contract.

The Contractor shall ensure familiarity with all annexures and appendices and comply with their requirements. Any deviations or non-compliance must be addressed through written approval from the Client.

In case of any conflict between the annexures or appendices and the main Contract terms, the provisions of the main Contract shall prevail unless expressly stated otherwise.

36. Other Conditions

36.1 General Compliance

The Contractor shall comply with all applicable laws, regulations, codes, and standards governing road maintenance works, including but not limited to labor laws, environmental regulations, safety standards, and other statutory requirements. Any failure to comply with such laws and regulations shall be considered a breach of contract, and the Contractor shall bear all resulting consequences, including penalties and corrective actions. The Contractor shall also adhere to industry best practices and ensure that all personnel, subcontractors, and suppliers engaged in the project operate within the boundaries of the law and the terms of this Agreement.

36.2 Interpretation of Contract

In the event of ambiguity or inconsistency between clauses of this Contract, the interpretation most consistent with the overall intent and objectives of the Agreement shall prevail. Should disputes regarding interpretation arise, they shall initially be resolved through consultation between the Client and Contractor. If unresolved, the matter shall follow the dispute resolution mechanism outlined in **Clause 18**. Both parties agree that all provisions of this Contract must be interpreted harmoniously to avoid rendering any clause redundant or inapplicable.

36.3 Confidentiality and Intellectual Property Rights

36.3.1 Ownership of Deliverables

36.3.1.1 All data, drawings, designs, reports, calculations, manuals, maps, photographs, and other deliverables produced or supplied by the Contractor under this Contract shall become the sole property of the Client upon submission. The Contractor shall not use, replicate, or disclose such deliverables for any purpose outside the scope of this Contract without the prior written consent of the Client.

36.3.2 Confidential Information

36.3.2.1 The Contractor agrees to treat all information provided by the Client or generated during the execution of this Contract as confidential. Such information shall not be disclosed to any third party or used for any purpose other than fulfilling the obligations under this Contract, except as required by law or with the written approval of the Client.

36.3.3 Intellectual Property Warranty

36.3.3.1 The Contractor warrants that all work, methodologies, and materials provided under this Contract do not infringe upon any existing intellectual property rights, including patents, copyrights, or trademarks of third parties, as per the applicable laws in India, including but not limited to the Copyright Act, 1957, and the Patents Act, 1970. The Contractor shall be solely

National Highways Infra Trust

 <p>NHIT National Highways Infra Trust</p>	General Conditions of Contract	Doc No.: NHIT/FY25-26/RFP/ Incident Management
---	---------------------------------------	--

responsible for resolving any claims or disputes arising from such infringements at its own cost.

36.3.4 Proprietary Technology and Methods

36.3.4.1 If the Contractor uses any proprietary technology, software, or methodologies owned by the Contractor during the performance of this Contract, it shall obtain prior written approval from the Client. Such proprietary elements shall remain the property of the Contractor unless explicitly transferred to the Client in writing.

36.3.5 Return of Data and Materials

36.3.5.1 Upon the termination or expiration of this Contract, the Contractor shall return or destroy all confidential information, data, and materials belonging to the Client, as instructed by the Client.

36.3.6 Compliance with Laws

36.3.6.1 The Contractor shall comply with all applicable intellectual property and confidentiality laws in India, including but not limited to the Indian Contract Act, 1872, the Copyright Act, 1957, and any relevant rules or guidelines issued by Indian authorities.

36.4 Third-Party Rights

This Contract is intended solely for the benefit of the Client and Contractor. It does not confer any rights, privileges, or remedies upon any third party, nor does it create any obligations or liabilities for the benefit of third parties. However, this limitation does not preclude the enforcement of obligations or liabilities directly related to third-party safety, property damage, or environmental compliance arising out of the Contractor's actions during the execution of this Contract.

36.5 Force of Documentation

This General Conditions of Contract (GCC), along with its annexures, appendices, and referenced documents such as technical specifications, MoRTH guidelines, IRC standards, and work orders, forms the complete and binding agreement between the Client and Contractor. Any deviations, amendments, or additions to these documents must be agreed upon in writing and signed by both parties to take effect. In the event of conflict between the main Agreement and its annexures or appendices, the order of precedence specified in the Special Conditions of Contract shall apply.

36.6 Provisions for Emergencies

In the event of an emergency, such as natural disasters, accidents, or critical incidents that threaten public safety, the Contractor shall take immediate action to mitigate risks and prevent further harm. This includes mobilizing resources, securing the affected area, and providing necessary assistance in coordination with local authorities. The Contractor must notify the Client of such actions within 24 hours and submit a detailed report outlining the measures taken and any anticipated costs. Any additional work performed under such circumstances shall be subject to review and approval by the Client.

36.7 Waiver

The failure of either party to enforce any provision of this Contract shall not constitute a waiver of their rights to enforce the same or any other provision at a later time. A waiver shall only be valid if expressed in writing and signed by the party granting it. Such a waiver shall be limited to the specific breach or circumstance outlined and shall not be construed as a continuing waiver of other or future breaches.

National Highways Infra Trust

	General Conditions of Contract	Doc No.: NHIT/FY25-26/RFP/ Incident Management
---	---------------------------------------	--

36.8 Entirety of Agreement

This Contract constitutes the entire agreement between the Client and Contractor concerning the scope of road maintenance works and supersedes all prior agreements, communications, and understandings, whether written or oral. No modifications or amendments to this Agreement shall be valid unless executed in writing and signed by both parties. Both parties affirm that they have entered into this Agreement based on its express terms and not in reliance on any representations, promises, or warranties not explicitly contained herein.

36.9 Survival of Terms

Provisions of this Contract that by their nature extend beyond its termination or expiration shall survive and remain in effect. This includes, but is not limited to, clauses related to confidentiality, intellectual property, warranties, dispute resolution, indemnities, and liabilities. The Contractor acknowledges that these surviving obligations are essential to protecting the Client's rights and interests even after the completion or termination of this Contract.

36.10 Acknowledgment

The Contractor acknowledges that they have read and understood the terms and conditions of this Contract, including all annexures, appendices, and referenced documents. By signing this Agreement, the Contractor agrees to be bound by its terms and confirms their capability to fulfill all obligations outlined herein. The Contractor also warrants that they have sought independent legal or professional advice as necessary to comprehend the implications of this Contract fully.

36.11 Language of the Contract

The official language of this Contract shall be English. All correspondence, documentation, instructions, and deliverables related to this Contract shall be prepared, submitted, and interpreted in English only. In the event of any discrepancy between versions of this Contract or its associated documents in any other language, the English version shall prevail.

The Contractor shall ensure that its personnel, subcontractors, and agents are adequately conversant in English to comply effectively with the terms and obligations under this Contract. Any translation of this Contract or related documentation into another language shall be for convenience only and shall not carry legal validity unless expressly agreed upon by both parties in writing.

The parties agree that clarity and consistency in communication are paramount to the successful execution of the Contract, and this provision is binding on all parties.

Annexure A2

Special Conditions of Contract

National Highways Infra Trust

	Special Conditions of Contract	Doc No.: NHIT/FY25-26/RFP/ Incident Management
---	---------------------------------------	--

Not Applicable

Annexure A3

List of Approved Makes

Annexure A3 – List of Approved Makes (V-01)

List of Approved Makes		
S.No	Items Description	Name of Approved Suppliers/Vendors
1	Cement	Ultratech Cement Ltd
		Ambuja Cement- Holcim
		J K Super/Laxmi
		Wonder
		Shree Cement
		Birla/Mangalam Cement
		ACC Ltd
2	Reinforcement Steel	1. SAIL
		2. TATA Steel
		3. Rastriya Ispat Nigam Ltd [RINL]
		4. Jindal Steel Power Ltd
		5. JSW Steel Ltd (Including former JSW Ispat/Ispat industries Ltd)
3	Plates	Essar Steel Limited
		SAIL
		Jindal Steel & Power Limited
		JSW Steel Ltd (Including former JSW Ispat/Ispat industries Ltd)
		RINL
		Uttam Galva Steel
		Bhushan Steel & Power
		Arcelor & Mittal
Tata Steel		
4	Structural Steel	1. Tata Steel
		2.SAIL
		3. RINL
		4. Jindal Steel Power Ltd
5	Bitumen (VG 30/ VG 40)	1. HPCL
		2. IOCL
		3. BPCL
		4. MRPL
		5. Reliance
6	Emulsion (RS & SS)	1. Hincol
		2. Tiki Tar Shell India Ltd.
		3. BPCL
		4. IOCL
7	Concrete Admixtures	1. FOSROC
		2. Sika
		3. BASF
		4. Dr. Fixit
8	AC Pipes	Local vendors complying IS requirement
9	PVC/HDPE Pipes	FIP
		Astral
		Finolex
		Prince
		Supreme Industries Ltd
		Kissan Irrigation Ltd.
		Jain Irrigation APL Apollo

Annexure A3 – List of Approved Makes (V-01)

List of Approved Makes		
S. No	Items Description	Name of Approved Suppliers/Vendors
10	High Tensile Steel strands	1. Usha Martin 2. TATA 3. Kataria
11	Sealant and sealant Primer for PQC	1. FOSROC 2. Sika 3. BASF 4. Dr. Fixit
12	Curing Compound	1. FOSROC 2. Sika 3. BASF 4. Dr. Fixit
13	Separation Membrane (LDPE)	1. Vishakha Polyfab 2. D.P. Wires
14	Hume Pipe	Local vendors complying IS requirement
15	Paver Blocks	Local vendors complying IS requirement
16	Drainage Spout	Local vendors complying IS requirement
17	Sheathing Pipes	1. Tirupati Plastomatics Private Limited 2. Usha Martin 3. Dynamic 4. Kataria
18	Expansion joints (Modular/Strip seal)	1. Dynamic Prestress(I) Pvt Ltd, Navi Mumbai 2. Maurer - Sanfield India Limited 3. Mageba Bridge Products Pvt. Ltd. Kolkata
19	Bearings	
19.01	Elastomeric bearing	1. Dynamic Prestress(I) Pvt Ltd, Navi Mumbai 2. Maurer - Sanfield India Limited 3. Mageba Bridge Products Pvt. Ltd. Kolkata
19.02	POT-PTFE Bearings	1. Dynamic Prestress(I) Pvt Ltd, Navi Mumbai 2. Maurer - Sanfield India Limited 3. Mageba Bridge Products Pvt. Ltd. Kolkata
20	Re Wall: Panels with all accessories like Geo Grid Materials, GI Clamp, etc	1. Maccaferri 2. Techfab India 3. Strata Geosystems 4. Reinforced Earth India Pvt. Ltd 5. Geosys India Infrastructure Pvt. Ltd.
21	Geocomposite Material for Filter Media	1. Maccaferri 2. Strata Geosystems 3. Techfab India
22	Traffic Signs, Marking and other Appurtenances:	
22.01	Retro Reflective Tapes for Signages	Any supplier with "3M/Orafol" Reflective sheet
22.02	Delineators (Roadway Indicators)	Any supplier with "3M/Orafol " Reflective sheet
22.03	Reflective pavement markers (road Studs)	Any supplier with "3M/Orafol/Kataline/Alcolite " Reflective sheet
22.04	Solar blinkers	Any supplier with "3M/Orafol/ Alcolite" Reflective sheet
22.05	Solar studs with red flashes	Any supplier with "3M/Orafol/ Alcolite" Reflective sheet

Annexure A3 – List of Approved Makes (V-01)

List of Approved Makes		
S. No	Items Description	Name of Approved Suppliers/Vendors
23	Highways & toll Illumination & Electrical works	
23.01	High mast	Bajaj/ Philips/ Crompton/ Valmont (upto 70M)/ Trans rail Lighting (up to 30M)/ Utkal (upto 30 M) Sigma Search light (upto 30M)/Utkarsh India Ltd.
23.02	Pole with Single Arm	For GI Poles - Bajaj/ Ridhdhi Poles/ Zenith Poles/ Subham Poles/ Aster Teleservices/Utkarsh India Ltd.
23.03	Median Lighting, Double Arm	For GI Poles - Bajaj/ Ridhdhi Poles/ Zenith Poles/ Subham Poles/ Aster Teleservices/ Utkarsh India Ltd.
23.04	Light inside/ under the Structure (i.e. VUP, PUP, Flyover, Toll Plaza canopy etc.)	Wipro/CGL/ Philips/Bajaj/ GE/ Osram/Havells/Sigma search light
23.05	HT Cable	Polycab/KEI / Ravin Cables/ Universal Cable/ Sterlite/ Gupta Power/ CCI/ Torrent Power/ Finolex /RPG
23.06	LT Cable	Polycab/KEI / Ravin Cables/ Universal Cable/ Torrent/Nicco/ Finolex /RPG/Havells/Cords/Thermos/Delton/Suyog
23.07	LT Panels	BCH/ Siemens/Schneider/ ABB/ L&T / C&S/ Manish Engineering, Mumbai / Akshar Electric. Baroda /Maktel, Vadodara/ Risha Control, Delhi/ Bharat Engineers, Vadodara/ Vidhyut Control, Ghaziabad/ Pyrotech Electronics, Udaipur/Milestone, Rudrapur / Unilec Engineer, Gurgaon/ Electro Control system, Noida
23.08	Junction Boxes	Sintex/Hensel
23.09	Cabel Termination	3M/Yamuna/Raychem/Gala shrinkfit
23.1	Cable Glands	Comet/VBI/Dowells/HMI/Sunil & Co/ Arup Engg/Quality Precision
23.11	Conduit	M. Chandra/Supreme/Precision/BEC Industries/ Elmech India
24	Pavement marking (Hot applied thermoplastic paint)	1. Setwell Coating (India) Pvt. Ltd. 2. Kataline group, Mumbai 3. Asian Paint, Mumbai 4. Automark Industries 5. Berger
25	Chequered Tiles (25mm thk)	Local vendors complying IS requirement
26	ATMS & Toll Equipment's	1. Efkon, Mumbai 2. Metro, Delhi 3. Rajdeep, MP 4. Devaditya Technocrats LLP 5. Qualix Information System LLP 6. Vaaan Infra Pvt Ltd 7. Superwave Communications & Infra Solutions Pvt Ltd
27	Metal Beam Crash Barrier	1. Safety First 2. AARNEEL Technocraft Private Limited 3. Vinfab Engineers India Limited 4. GR Infra Projects Ltd 5. Utkarsh India Ltd. 6. Jindal (india) Limited 7. HI-TECH PIPES LIMITED 8. Prakash Asphaltting and Toll Highways India Limited

Annexure A3 – List of Approved Makes (V-01)

List of Approved Makes		
S. No	Items Description	Name of Approved Suppliers/Vendors
28	Static Weigh Bridge	RICELAKE WEIGHING SYSTEM
		AVERY INDIA LTD
		ESSAE DIGITRONICS PVT. LTD. Ashbee System Ltd.
29	Weigh In Motion	1. Efkon, Mumbai 2. Metro, Delhi 3. Rajdeep, MP 4. Ashbee System Ltd.
30	Aluminium Section	Hindalco
		BALCO
		NALCO
31	Bajri/Frosted/Wired Glass/ Clear Float Glass(5mm Thick) for Doors, windows,	saint Gobain
		Asahi Float
		Modiguard
32	Ceramic/ Vitrified Tiles	Somany Ceramics Limited
		Nitco Tiles
		Kajaria Ceramics
		Johnson Tiles
		Asian Granito India Ltd.
33	Paints	Jotun
		Asian
		Grandpolycoat
		Nerolac
		Berger
34	Sanitary Fittings	Parryware
		Jaquar
		Hindware
		Cera
		Somany
35	ACP Panels	Eurobond industries
		Alcan Composites India
		Aludecor Lamination
36	Cement Board	SHERA cement board by Mahapant fibre cement
		AEROCON C board from HIL
37	Mortised Locks & Door Accessories	Assa Abloy India Pvt. Ltd (Yale)
		Everiet
		Godrej & Boyce Manufacturing Company Limited
		Link Group of Industries
		Europa
38	Pipes-MS Tube & Pipes (Galvanized)(IS 1239/IS 3589)	Tata Steel
		Indus
		Jindal
		Advance Steel Tubes Ltd.
		PS Steel tubes Ltd APL Apollo
39	Bituminous Paint	Shalimar
		STP
		Tiki Tar Industries

Annexure A3 – List of Approved Makes (V-01)

List of Approved Makes		
S. No	Items Description	Name of Approved Suppliers/Vendors
40	Gypsum Board False Ceiling/Partition Wall/ Fireproof Partition	Saint Gobain Gyproc India Ltd.
		Borai Gypsum India Pvt. Ltd.
		Gypsonite
41	Fasteners for Structural Steel	Nexo Fasteners
		Lakshmi precision Screws Ltd.
		Precision Taps & dies pvt. Ltd.
		Bharti
		Deepak fasteners,
		Sundaram fasteners Ltd
42	Structural Hollow Steel Sections (Square & Rectangular)	Vinay Wires & Poly products (P) limited - (VWPPL)
		Hi Tech Pipes, Limited, TISCO
		Riddhi Steel & Tube Limited
		APL Apollo
43	Structural Tubular Sections	TISCO
		Jindal Steel
		SAIL
		Welspun
		Maharashtra Seamless
		Surya Roshni
		Ratnamani
		PSL Industries
		APL Apollo
44	RBT/CONCERTINA COIL/BARBED WIRE	Zonate Wire Industries
		Guru Krupa Wire Netting Industries
		A 1 Fence Products Company Pvt. Ltd.
		Sai Wire
		Parmeshwar Wire Products

Annexure A4

Utility shifting guidelines for safety, compliance, and timely execution

National Highways Infra Trust

 <p>NHIT National Highways Infra Trust</p>	Utility shifting guidelines	Doc No.: NHIT/FY25-26/RFP/ Incident Management
---	------------------------------------	--

Not Applicable

Annexure A5 NHIT's EHS Policy

Annexure A5- EHS Responsibilities and Requirements – Work on Live Road

1. General

1.1. Personal Protective Equipment & Safety Appliances

The Contractor / Agency shall provide all the PPE (Personal Protective Equipment) and safety appliances required to carry out the job to all the workmen at its own cost and expenses.

1.2. PTW System (Wherever applicable, Sole discretion of - NHIT

The Contractor / Agency shall adhere to all the provisions of EHS requirements. In case of non-compliance or continuous failure in the implementation of any of EHS provisions. NHIT may impose stoppage of work without any cost or time implications /or impose a suitable penalty for non-compliance.

1.3. EHS violation Penalty List in INR

1.3.1. Non usage of PPEs – 1000/-

1.3.2. Violation of Barricading Requirements 2,000/-

1.3.3. Caution boards/signs not displayed.1000/-

1.3.4. Work without PTW system 1000/- (EPC, O&M and Work on Live Road)

1.3.5. Usage tools & tackles without valid third-party certification 2000/-

1.3.6. Deployment and usage of cranes and equipment without valid third-party certification 5000/-

1.3.7. Main carriage way blockage without prior permission and PTW 5,000/-

1.3.8. Failure to deploy a shadow vehicle: ₹2,000 per instance. However, the requirement for a shadow vehicle may be waived at the sole discretion of the EHS Manager, depending on the duration of the activity and the severity of the hazard.

1.3.9. Transportation of manpower using makeshift arrangements or a shadow vehicle: ₹2,000 per instance / per person.

1.3.10. Any other unsafe act and condition 2000/-

Remarks: Fines & Penalties shall be decided & revised by NHIT project manager. Fines & Penalties amount will be deducted from Contractor / Agency payment. Above penalties are per violation per occasion basis.

Repeated EHS violations will result in escalating disciplinary measures. A third occurrence of the same violation may lead to temporary suspension, while a fifth recurrence may result in permanent contract termination.

2. Method Statement & HIRA (Wherever applicable, Sole discretion of NHIT. The Contractor / Agency shall submit a detailed Work method statement and Hazard Identification & Risk Assessment (HIRA) for review and approval before commencing work.

3. Work on Live Road (Wherever applicable, Sole discretion of NHIT

3.1. Work Zone - Contractor / Agency shall create and maintain the Traffic control zones as per Section 4 of IRC SP 55 2014 – Advance warning zone, Approach transition zone, Activity zone, Terminal transition zone, Work zone end, ref figure (a) attached as annexure.

- 3.1.1. Provide MS board with “Arrow marking & Work in progress” display @ 100 meters ahead of the work zone and fix red flags over it for good visibility.
- 3.1.2. Ensure to provide LED chevron or blinker in case of fog time or working during inadequate illumination.
- 3.1.3. Display sign boards such as Go Slow, Speed Limit etc.
- 3.1.4. Deploy flag man along with Red & Green flags with a whistle or virtual flagman to be placed for better visibility and a risk-free approach.
- 3.1.5. Contractor / Agency should ensure sufficient manpower to provide the safety arrangement on live carriage way.
- 3.1.6. MS board with display “Men at Work” (900 mm) & Arrow marking should be placed on the live carriageway in particular lane at least 500 m ahead of working place.

4. ISO 14001 and ISO 45001 Requirement

The Contractors and Agencies are encouraged to comply with the requirements of ISO 14001 and ISO 45001.

5. Environment

General – The Contractor/Agency shall be responsible for the storage and disposal of any waste generated as a result of its operations and comply with the respective state / central pollution control board regulations.

Routine maintenance/Initial improvement works – The Contractor/Agency shall obtain Consent to Establish (CTE) and Consent to Operate (CTO) at its own cost and expenses from the respective State Pollution Control Board and comply with the Hazardous and Other Wastes (Management and Transboundary Movement) Rules, 2016.

Annexure - figure (a)

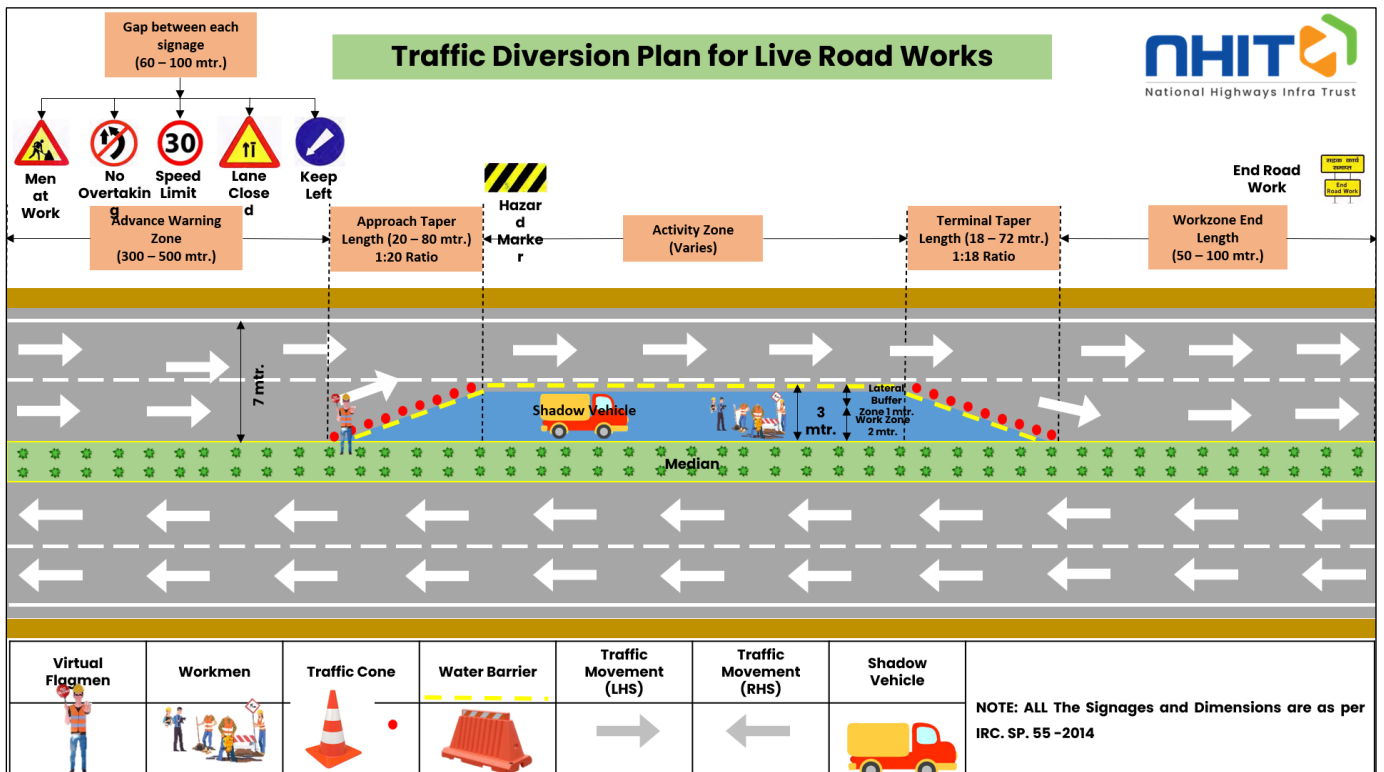

Annexure B1 Bank Guarantee Template for Bid Security

National Highways Infra Trust

 National Highways Infra Trust	Bank Guarantee Template	Doc No.: NHIT/FY25-26/RFP/ Incident Management
--	--------------------------------	--

Bank Guarantee Format for Bid Security

(To be stamped in accordance with Stamp Act if any, of the country of issuing bank)

Ref.: **Tender No.** _____, **dated** _____

Bank Guarantee:

Date:

WHEREAS _____ (Name of Bidder) (hereinafter called "the bidder") has submitted his bid dated _____ (date) for the **Tender No.** _____, **dated** _____ (hereinafter called "the Bid").

KNOW ALL MEN by these presents that We, _____ [Name of Bank] of _____ [Name of Country] having our registered office at _____ (hereinafter called "the Bank") are bound unto _____ [Name of Client] (hereinafter called "the Client") in the sum of Rs. _____ (Rupees _____ Lakhs Only) for which payment will and truly to be made to the said Client the Bank binds himself, his successors and assigns by these presents.

SEALED with the Common Seal of the said Bank this _____ day of _____ 202_

THE CONDITIONS of this obligation are:

1. If the Bidder withdraws his Bid during the period of bid validity specified in the Bid document; or
 2. If the Bidder does not accept the correction of arithmetical errors of his Bid Price in accordance with the Instructions to Bidder; or
 3. If the Bidder having been notified of the acceptance of his Bid by the Client during the period of bid validity,
 - a. fails or refuses to execute the Form of Agreement in accordance with the Instructions to Bidders, if required; or
 - b. fails or refuses to furnish the Performance Security, in accordance with the Instructions to Bidders,
- we undertake to pay the Client up to the above amount upon receipt of his first written demand, without the Client having to substantiate his demand, provided that in his demand the Client will note that the amount claimed by him is due to him owing to the occurrence of one or any of the conditions, specifying the occurred condition or conditions.

This Guarantee will remain in force up to and including the date 120 (one hundred and twenty) days after the deadline for submission of bids as such deadline is stated in the Instructions to Bidders or as it may be extended by the Client, notice of which extension(s) to the Bank is hereby waived. Any demand in respect of this Guarantee should reach the Bank not later than the above date.

Notwithstanding anything contained herein before, our liability under this guarantee is restricted to Rs. _____ (Rs. _____) and the guarantee shall remain valid till _____. Unless a claim or a demand in writing is made upon us on or before _____ all our liability under this guarantee shall cease.

This guarantee shall also be operatable at our New Delhi Branch located at _____, from whom, confirmation regarding the issue of this guarantee or extension / renewal thereof shall be made available on demand. In the contingency of this guarantee being invoked and payment there under claimed, the said branch shall accept such invocation letter and make payment of amounts so demanded under the said invocation

National Highways Infra Trust

 National Highways Infra Trust	Bank Guarantee Template	Doc No.: NHIT/FY25-26/RFP/ Incident Management
--	--------------------------------	--

DATE _____

SIGNATURE OF THE BANK _____

SEAL OF THE BANK _____

SIGNATURE OF THE WITNESS _____

Name and Address of the Witness _____

The bank guarantee shall be issued by a bank (Nationalized/Scheduled) located in India

NOTE for Issuing Bank (Not to be included in the BG):-

- 1. The stamp papers of appropriate value shall be purchased in the name of bank, who issues the "Bank Guarantee".*
- 2. The bank guarantee shall be from a Nationalized Indian Bank or reputed foreign commercial Bank acceptable to client for Foreign Consultant with counter guarantee from Nationalized Bank. Bank guarantee furnished by Foreign consultant shall be confirmed by any Nationalized Bank in India.*
3. The bank guarantee(s) contain(s) the name, designation and Code number of the officer(s) signing the guarantee(s).
4. The address, telephone no. and other details of the Head Office of the Bank as well as of issuing branch should be mentioned on the covering letter of issuing Branch.
5. The bank guarantee for Rs. 10,000 and above is signed by at least two officials (or as per the norms prescribed by the RBI in this regard).
6. The Bank Guarantee shall be transmitted through SFMS gateway to our banker with following details:

S. No.	Particulars	Details
1	Name of Beneficiary	
2	Beneficiary Bank Account No.	
3	Beneficiary Bank Branch IFSC	
4	Swift Code (For foreign Applicants)	
5	Beneficiary Bank Branch Name	
6	Beneficiary Bank Address	

7. The confirmation with supporting details if any shall be specifically mentioned in the covering letter issued with the Bank Guarantee.

National Highways Infra Trust

	Bank Guarantee Template	Doc No.: NHIT/FY25-26/RFP/ Incident Management
---	--------------------------------	--

Annexure B2 Performance Security Template

National Highways Infra Trust

 <p>NHIT National Highways Infra Trust</p>	Bank Guarantee Template	Doc No.: NHIT/FY25-26/RFP/ Incident Management
---	--------------------------------	--

Bank Guarantee for Performance Security/Additional Performance Security

To,
NHIT Eastern Projects Private Limited (NEPPL)
(Unit of National Highways Infra Trust)
Unit No. 325, 3rd Floor, D-21 Corporate Park,
Sector-21, Dwarka, New Delhi – 110077

WHEREAS:

- (A) _____ [name and address of contractor] (hereinafter called the “**Contractor**”) and NHIT Eastern Projects Private Limited, Unit No. 325, 3rd Floor, D-21 Corporate Park, Sector-21, Dwarka, New Delhi-110077, (hereinafter called the “**Concessionaire**”) have entered into an agreement (hereinafter called the “**Agreement**”) for the [Name of Work], subject to and in accordance with the provisions of the Agreement
- (B) The Agreement requires the Contractor to furnish a Performance Security for due and faithful performance of its obligations, under and in accordance with the Agreement, during the {Construction Period/ Defects Liability Period and Maintenance Period} (as defined in the Agreement) in a sum of Rs..... cr. (Rupees crore) (the “**Guarantee Amount**”).
- (C) We, through our branch at (the “**Bank**”) have agreed to furnish this bank guarantee (*hereinafter called the “**Guarantee**”*) by way of Performance Security.

NOW, THEREFORE, the Bank hereby, unconditionally and irrevocably, guarantees and affirms as follows:

1. The Bank hereby unconditionally and irrevocably guarantees the due and faithful performance of the Contractor's obligations during the {Construction Period/ Defects Liability Period and Maintenance Period} under and in accordance with the Agreement, and agrees and undertakes to pay to the Concessionaire, upon its mere first written demand, and without any demur, reservation, recourse, contest or protest, and without any reference to the Contractor, such sum or sums up to an aggregate sum of the Guarantee Amount as the Concessionaire shall claim, without the Concessionaire being required to prove or to show grounds or reasons for its demand and/or for the sum specified therein.
2. A letter from the Concessionaire, under the hand of an officer not below the rank of Head SPV in the NHIT Eastern Projects Private Limited, that the Contractor has committed default in the due and faithful performance of all or any of its obligations under and in accordance with the Agreement shall be conclusive, final and binding on the Bank. The Bank further agrees that the Concessionaire shall be the sole judge as to whether the Contractor is in default in due and faithful performance of its obligations during and under the Agreement and its decision that the Contractor is in default shall be final and binding on the Bank, notwithstanding any differences between the Concessionaire and the Contractor, or any dispute between them pending before any court, tribunal, arbitrators or any other authority or body, or by the discharge of the Contractor for any reason whatsoever.
3. In order to give effect to this Guarantee, the Concessionaire shall be entitled to act as if the Bank

National Highways Infra Trust

	Bank Guarantee Template	Doc No.: NHIT/FY25-26/RFP/ Incident Management
---	--------------------------------	--

were the principal debtor and any change in the constitution of the Contractor and/or the Bank, whether by their absorption with any other body or corporation or otherwise, shall not in any way or manner affect the liability or obligation of the Bank under this Guarantee.

4. It shall not be necessary, and the Bank hereby waives any necessity, for the Concessionaire to proceed against the Contractor before presenting to the Bank its demand under this Guarantee.
5. The Concessionaire shall have the liberty, without affecting in any manner the liability of the Bank under this Guarantee, to vary at any time, the terms and conditions of the Agreement or to extend the time or period for the compliance with, fulfilment and/ or performance of all or any of the obligations of the Contractor contained in the Agreement or to postpone for any time, and from time to time, any of the rights and powers exercisable by the Concessionaire against the Contractor, and either to enforce or forbear from enforcing any of the terms and conditions contained in the Agreement and/or the securities available to the Concessionaire, and the Bank shall not be released from its liability and obligation under these presents by any exercise by the Concessionaire of the liberty with reference to the matters aforesaid or by reason of time being given to the Contractor or any other forbearance, indulgence, act or omission on the part of the Concessionaire or of any other matter or thing whatsoever which under any law relating to sureties and guarantors would but for this provision have the effect of releasing the Bank from its liability and obligation under this Guarantee and the Bank hereby waives all of its rights under any such law.
6. This Guarantee is in addition to and not in substitution of any other guarantee or security now or which may hereafter be held by the Concessionaire in respect of or relating to the Agreement or for the fulfilment, compliance and/or performance of all or any of the obligations of the Contractor under the Agreement.
7. Notwithstanding anything contained hereinbefore, the liability of the Bank under this Guarantee is restricted to the Guarantee Amount and this Guarantee will remain in force for the period specified in paragraph 8 below and unless a demand or claim in writing is made by the Concessionaire on the Bank under this Guarantee all rights of the Concessionaire under this Guarantee shall be forfeited and the Bank shall be relieved from its liabilities hereunder.
8. The Guarantee shall cease to be in force and effect on ****\$. Unless a demand or claim under this Guarantee is made in writing before expiry of the Guarantee, the Bank shall be discharged from its liabilities hereunder.
9. The Bank undertakes not to revoke this Guarantee during its currency, except with the previous express consent of the Concessionaire in writing and declares and warrants that it has the power to issue this Guarantee and the undersigned has full powers to do so on behalf of the Bank.
10. Any notice by way of request, demand or otherwise hereunder may be sent by post addressed to the Bank at its above referred branch, which shall be deemed to have been duly authorised to receive such notice and to effect payment thereof forthwith, and if sent by post it shall be deemed to have been given at the time when it ought to have been delivered in due course of post and in proving such notice, when given by post, it shall be sufficient to prove that the envelope containing the notice was posted and a certificate signed by an officer of the Concessionaire that the envelope was so posted shall be conclusive.

National Highways Infra Trust

 National Highways Infra Trust	Bank Guarantee Template	Doc No.: NHIT/FY25-26/RFP/ Incident Management
--	--------------------------------	--

11. This Guarantee shall come into force with immediate effect and shall remain in force and effect for up to the date specified in paragraph 8 above or until it is released earlier by the Concessionaire pursuant to the provisions of the Agreement.
12. This guarantee shall also be operatable at our..... Branch at New Delhi, from whom, confirmation regarding the issue of this guarantee or extension / renewal thereof shall be made available on demand. In the contingency of this guarantee being invoked and payment thereunder claimed, the said branch shall accept such invocation letter and make payment of amounts so demanded under the said invocation.
13. The guarantor/bank hereby confirms that it is on the SFMS (Structural Finance Messaging System) platform & shall invariably send an advice of this Bank Guarantee to the designated bank of NHIT Eastern Projects Private Limited, details of which is as under:

S. No.	Particulars	Details
1.	Name of Beneficiary	NHIT Eastern Projects Private Limited
2.	Name of Bank	State Bank of India
3.	Account No.	42763768030
4.	IFSC Code	SBIN0017313

Signed and sealed this day of, 20..... at

SIGNED, SEALED AND DELIVERED

For and on behalf of the Bank by: (Signature)

(Name)

(Designation)

(Code Number)

(Address)

NOTES:

- (i) The bank guarantee should contain the name, designation and code number of the officer(s) signing the guarantee.
- (ii) The address, telephone number and other details of the head office of the Bank as well as of issuing branch should be mentioned on the covering letter of issuing branch.

National Highways Infra Trust

	Bank Guarantee Template	Doc No.: NHIT/FY25-26/RFP/ Incident Management
---	--------------------------------	--

Annexure B3 Bank Guarantee Template

Guarantee for Advance Payment

To,

	Page 7 of 10	
--	--------------	--

National Highways Infra Trust

 National Highways Infra Trust	Bank Guarantee Template	Doc No.: NHIT/FY25-26/RFP/ Incident Management
--	--------------------------------	--

NHIT Eastern Projects Private Limited (NEPPL)
(Unit of National Highways Infra Trust)
Unit No. 325, 3rd Floor, D-21 Corporate Park,
Sector-21, Dwarka, New Delhi – 110077

WHEREAS:

- (A)[name and address of contractor] (hereinafter called the “**Contractor**”) has executed an agreement (hereinafter called the “**Agreement**”) with NHIT Eastern Projects Private Limited, Unit No. 325, 3rd Floor, D-21 Corporate Park, Sector-21, Dwarka, New Delhi-110077, (hereinafter called the “**Concessionaire**”) have entered into an agreement (hereinafter called the “**Agreement**”) for the [Name of Work], subject to and in accordance with the provisions of the Agreement
- (B) In accordance with Clause [.....] of the Agreement, the Concessionaire shall make to the Contractor an interest bearing [Specify Percentage] advance payment (herein after called “**Advance Payment**”) equal to [__% (____ per cent)] of the Contract Price; and that the Advance Payment shall be made in _____ instalments subject to the Contractor furnishing an irrevocable and unconditional guarantee by a scheduled bank for an amount equivalent to 110% (one hundred and ten percent) of such instalment to remain effective till the complete and full repayment of the instalment of the Advance Payment as security for compliance with its obligations in accordance with the Agreement. The amount of {first/second} installment of the Advance Payment is Rs. ----- cr. (Rupees ----- crore) and the amount of this Guarantee is Rs. - ----- cr. (Rupees ----- crore) (the “**Guarantee Amount**”)[§].
- (C) We, through our branch at (the “**Bank**”) have agreed to furnish this bank guarantee (*hereinafter called the “**Guarantee**”*) for the Guarantee Amount.

NOW, THEREFORE, the Bank hereby, unconditionally and irrevocably, guarantees and affirms as follows:

1. The Bank hereby unconditionally and irrevocably guarantees the due and faithful repayment on time of the aforesaid instalment of the Advance Payment under and in accordance with the Agreement, and agrees and undertakes to pay to the **Concessionaire**, upon its mere first written demand, and without any demur, reservation, recourse, contest or protest, and without any reference to the Contractor, such sum or sums up to an aggregate sum of the Guarantee Amount as the **Concessionaire** shall claim, without the **Concessionaire** being required to prove or to show grounds or reasons for its demand and/or for the sum specified therein.
2. A letter from the Concessionaire, under the hand of an officer not below the rank of Head SPV in the NHIT Eastern Projects Private Limited, that the Contractor has committed default in the due and faithful performance of all or any of its obligations for the repayment of the instalment of the Advance Payment under and in accordance with the Agreement shall be conclusive, final and binding on the Bank. The Bank further agrees that the Concessionaire shall be the sole judge as to whether the Contractor is in default in due and faithful performance of its obligations during and under the Agreement and its decision that the Contractor is in default shall be final and binding on the Bank, notwithstanding any differences between the Concessionaire and the Contractor,

[§] The Guarantee Amount should be equivalent to _____% of the value of the applicable instalment.

National Highways Infra Trust

	Bank Guarantee Template	Doc No.: NHIT/FY25-26/RFP/ Incident Management
---	--------------------------------	--

or any dispute between them pending before any court, tribunal, arbitrators or any other authority or body, or by the discharge of the Contractor for any reason whatsoever.

3. In order to give effect to this Guarantee, the Concessionaire shall be entitled to act as if the Bank were the principal debtor and any change in the constitution of the Contractor and/or the Bank, whether by their absorption with any other body or corporation or otherwise, shall not in any way or manner affect the liability or obligation of the Bank under this Guarantee.
4. It shall not be necessary, and the Bank hereby waives any necessity, for the Concessionaire to proceed against the Contractor before presenting to the Bank its demand under this Guarantee.
5. The Concessionaire shall have the liberty, without affecting in any manner the liability of the Bank under this Guarantee, to vary at any time, the terms and conditions of the Advance Payment or to extend the time or period of its repayment or to postpone for any time, and from time to time, any of the rights and powers exercisable by the Concessionaire against the Contractor, and either to enforce or forbear from enforcing any of the terms and conditions contained in the Agreement and/or the securities available to the Concessionaire, and the Bank shall not be released from its liability and obligation under these presents by any exercise by the Concessionaire of the liberty with reference to the matters aforesaid or by reason of time being given to the Contractor or any other forbearance, indulgence, act or omission on the part of the Concessionaire or of any other matter or thing whatsoever which under any law relating to sureties and guarantors would but for this provision have the effect of releasing the Bank from its liability and obligation under this Guarantee and the Bank hereby waives all of its rights under any such law.
6. This Guarantee is in addition to and not in substitution of any other guarantee or security now or which may hereafter be held by the Concessionaire in respect of or relating to the Advance Payment.
7. Notwithstanding anything contained hereinbefore, the liability of the Bank under this Guarantee is restricted to the Guarantee Amount and this Guarantee will remain in force for the period specified in paragraph 8 below and unless a demand or claim in writing is made by the Concessionaire on the Bank under this Guarantee all rights of the Concessionaire under this Guarantee shall be forfeited and the Bank shall be relieved from its liabilities hereunder.
8. The Guarantee shall cease to be in force and effect on ****.§ Unless a demand or claim under this Guarantee is made in writing on or before the aforesaid date, the Bank shall be discharged from its liabilities hereunder.
9. The Bank undertakes not to revoke this Guarantee during its currency, except with the previous express consent of the Concessionaire in writing and declares and warrants that it has the power to issue this Guarantee, and the undersigned has full powers to do so on behalf of the Bank.
10. Any notice by way of request, demand or otherwise hereunder may be sent by post addressed to the Bank at its above referred branch, which shall be deemed to have been duly authorised to receive such notice and to effect payment thereof forthwith, and if sent by post it shall be deemed to have been given at the time when it ought to have been delivered in due course of post and in proving such notice, when given by post, it shall be sufficient to prove that the envelope

§ Insert a date being _____ days after the end of one year from the date of payment of the Advance payment to the Contractor (in accordance with Clause ____ of the Agreement).

National Highways Infra Trust

 National Highways Infra Trust	Bank Guarantee Template	Doc No.: NHIT/FY25-26/RFP/ Incident Management
--	--------------------------------	--

containing the notice was posted and a certificate signed by an officer of the Concessionaire that the envelope was so posted shall be conclusive.

11. This Guarantee shall come into force with immediate effect and shall remain in force and effect up to the date specified in paragraph 8 above or until it is released earlier by the Concessionaire pursuant to the provisions of the Agreement.
12. This guarantee shall also be operatable at our..... Branch at New Delhi, from whom, confirmation regarding the issue of this guarantee or extension / renewal thereof shall be made available on demand. In the contingency of this guarantee being invoked and payment thereunder claimed, the said branch shall accept such invocation letter and make payment of amounts so demanded under the said invocation.
13. The guarantor/bank hereby confirms that it is on the SFMS (Structural Finance Messaging System) platform & shall invariably send an advice of this Bank Guarantee to the designated bank of NHIT Eastern Projects Private Limited, details of which is as under:

S. No.	Particulars	Details
1.	Name of Beneficiary	NHIT Eastern Projects Private Limited
2.	Name of Bank	State Bank of India
3.	Account No.	42763768030
4.	IFSC Code	SBIN0017313

Signed and sealed this day of, 20..... at

SIGNED, SEALED AND DELIVERED

For and on behalf of the Bank by: (Signature)

(Name)

(Designation)

(Code Number)

(Address)

NOTES:

- (i) The bank guarantee should contain the name, designation and code number of the officer(s) signing the guarantee.
- (ii) The address, telephone number and other details of the head office of the Bank as well as of issuing branch should be mentioned on the covering letter of issuing branch.

Annexure C1

Contract Data Sheet

National Highways Infra Trust



Contract Data Sheet

Doc No.: NHIT/FY25-26/RFP/
Incident Management-02

Contents

1. Employer and Contractor – Contact Information.....	2
1.1. Employer (Client) Contact Details.....	2
1.2. Contractor Contact Details (As per RFP Clause 1.4).....	2
2. Bid Invitation & Contract Overview (As per RFP Clause 1.1 & 1.2 of RFP; GCC Clause 2).....	2
2.1. Project Title (Clause 4 of RFP).....	2
2.2. Scope of Work (Brief Overview) (Clause 4.1 of RFP & Annexure [C2] of RFP).....	2
2.3. Contract Type & Payment Terms (GCC Clause 14; RFP Clause 2.2.14).....	2
2.4. Bid Reference & Contract Number.....	3
2.5. Key Dates & Milestones (Clause 1.2 of RFP).....	3
3. Time and Performance Obligations	3
3.1. Commencement and Completion Dates:.....	4
3.2. Contract Duration.....	4
3.3. Defects Liability Period (Ref: GCC Clause 29).....	4
3.4. Substantial Completion: (Ref. GCC Clause 23).....	5
4. Instructions to Bidders (ITB)	5
4.1. Definitions & Interpretations (Ref: RFP Clause 2.1).....	5
4.2. Earnest Money Deposit (EMD) (Ref: RFP Clause 2.4.1).....	5
4.3. Electronic Submission (If Applicable) (Ref: RFP Clause 2.3.2.8).....	6
5. Eligibility & Qualification Criteria.....	6
5.1. Financial Eligibility (Ref: RFP Clause 3.6.1 & Clause 12.1).....	6
5.2. Work Experience (Ref: RFP Clause 3 & Clause 12.2).....	6
6. Project Information (Ref: RFP Clause 4).....	7
6.1. Time for Completion & Key Dates (Ref: GCC Clause 3.1 & Clause 4; RFP Annexure [C2]).....	7
6.2. Milestones & Performance Benchmarks (RFP Clause 4; Annexure [C2]).....	7
6.3. Project Scope (Ref: RFP Clause 4; Annexure [C2]).....	7
6.4. Project Location & Length (Ref: RFP Clause 4.2.4; Annexure [C4]).....	7
6.5. Technical Specifications & Standards (Ref: RFP Clause 11.4.2, Section 6.3, Annexure [C7]).....	7
7. Financial Proposal (Ref: RFP Clause 9).....	8
7.1. Payment Schedule (Ref: RFP Clause 9.2 & GCC Clause 14).....	8
7.2. Bills of Quantities (BoQ) (Ref: RFP Clause 9.3).....	8
8. Performance & Security Documents (Ref: RFP Clause 10.1 & 10.2).....	8
8.1. Performance Security (Ref: GCC Clause 33 & RFP Clause 10.1).....	8
8.2. Advance Payment Security (Ref: RFP Clause 10.2).....	8
9. Payments, Financials, and Security	9
9.1. Insurance Requirements (Ref: GCC Clause 12).....	9
9.2. Currency of Payment (Ref: RFP Clause 2.2.14.3).....	9
9.3. Total Contract Price (RFP Clause 2.1; 2.3).....	9
9.4. Liquidated Damages for Delay (Ref: GCC Clause 30).....	9
10. Supplementary Information for Bidders	9
12. Project-Specific Annexures (Ref: RFP Clause 18).....	11

National Highways Infra Trust

 National Highways Infra Trust	<h2>Contract Data Sheet</h2>	Doc No.: NHIT/FY25-26/RFP/ Incident Management-02
--	------------------------------	---

Contract Data Sheet (CDS)

This Contract Data Sheet (CDS) provides project-specific details as referenced in the Request for Proposal (RFP) for Providing Incident Management Vehicles and General Conditions of Contract.

1. Employer and Contractor – Contact Information

1.1. Employer (Client) Contact Details

Detail	Information
Name of Employer	National Highways Infra Trust
Office Address	Unit No. 325, 3rd Floor, D-21 Corporate Park, Sector-21, Dwarka, New Delhi – 110077.
Official Contact Person	Sandeep Khosa, GM Procurement
Phone Number	011 49253927
Email ID	tender@nhit.co.in
Employer's Representative (if applicable)	N.A.

1.2. Contractor Contact Details (As per RFP Clause 1.4)

Detail	Information
Name of Contractor	
Office Address	
Authorized Representative	
Phone Number	
Email ID	
If JV/Consortium:	

2. Bid Invitation & Contract Overview (As per RFP Clause 1.1 & 1.2 of RFP; GCC Clause 2)

2.1. Project Title (Clause 4 of RFP)

Request for Proposal (“RFP”) issued by National Highways Infra Trust (NHIT) for Engagement of Agency/Firm for Providing Incident Management Vehicles at Project sites under SPVs of NHIT.

2.2. Scope of Work (Brief Overview) (Clause 4.1 of RFP & Annexure [C2] of RFP)

As per attached Annexure C2

2.3. Contract Type & Payment Terms (GCC Clause 14; RFP Clause 2.2.14)

The contract shall be awarded on Item Rate basis. The payment structure shall follow the provisions outlined in the RFP and GCC, as detailed below:

Payment Component	Details
Advance Payment	Not Applicable.
Mobilization Advance Recovery	Not Applicable.
Interim / Milestone Payments	Payments shall be made Monthly , subject to deductions for advance recovery, retention money, and statutory taxes.
Retention Money (if Applicable)	[06] % deduction from each bill, Subject to up to a maximum of 5% of the contract value. Refundable within 30 days after rectifying all defects which were identified on DLP period. Retention money can be released on submission of equivalent value of Bank Guarantee (BG).
Deductions & Recoveries	Deductions shall include statutory taxes, liquidated damages (if any), and advance recovery as per contract terms.

National Highways Infra Trust

 National Highways Infra Trust	Contract Data Sheet	Doc No.: NHIT/FY25-26/RFP/ Incident Management-02
--	----------------------------	---

Price Adjustments (if applicable)	Adjustments for inflation, material cost variations, or statutory changes as per the agreed formula.
Performance Security	[05] % of Contract Value, submitted as BG or FDR , valid until 30 days from the end of the Defect Liability Period (DLP).
Final Payment	Released upon successful completion, certification, and compliance with contract conditions.
Defect Liability Period (DLP) Payment	Any withheld amounts for DLP shall be released after 30 days of rectification of defects within the specified period.
Bank Guarantees (BGs) & Validity	As per the CDS, the Performance Bank Guarantee (PBG) shall be valid for a minimum period of 13 months from the date of completion of the contract or as per the duration specified in the contract, whichever is later
Website	www.nhit.co.in

Note: NHIT shall be responsible for contract administration, ensuring compliance with the terms and conditions of the RFP and GCC, and overseeing project execution.

2.4. Bid Reference & Contract Number

The contract shall be identified by the following references:

Description	Reference
Bid Reference Number	NHIT/FY25-26/RFP/Incident Management-02
Contract Number	N.A.
Project Code (if applicable)	N.A.
Package Number (if applicable)	N. A.

2.5. Key Dates & Milestones (Clause 1.2 of RFP)

Event Description	Date & Time	Location / Mode (Online/Offline)
Invitation of RFP	16.03.2026	Online & Offline (NHIT Office)
Last Date for Receiving Queries / Clarifications	19.03.2026	Online
Pre-Bid Meeting Date	N.A.	N.A.
Pre-Bid Meeting Venue	N.A.	N.A.
Client's Response to Queries / Clarifications	20.03.2026	Online
Last Date of Bid Submission	25.03.2026, 14:00 Hrs	Online & Offline (NHIT Office)
Submission of Bid Security & Mandatory Documents	Along with Bid documents	Online & Offline (NHIT Office)
Opening of Technical Bid	25.03.2026, 16:00 Hrs	Online & Offline (NHIT Office)
Declaration of Eligible / Qualified Bidders	To be intimated later	Online
Opening of Financial Bid	To be intimated later	Online & Offline (NHIT Office)
Letter of Award (LOA)	To be intimated later	Online
Bid Validity Period	120 Days from Submission Date, as per RFP	----
Signing of Agreement	To be intimated later	Online & Offline (NHIT Office)

Note: Dates are indicative and subject to change via addendum.

3. Time and Performance Obligations

	Page 3 of 11	
--	--------------	--

National Highways Infra Trust

 <p>NHIT National Highways Infra Trust</p>	<h2>Contract Data Sheet</h2>	<p>Doc No.: NHIT/FY25-26/RFP/ Incident Management-02</p>
---	------------------------------	---

3.1. Commencement and Completion Dates:

(RFP Clause 4; Annexure [C2] of RFP – Scope of Work; Clause 3 of GCC)

Description	Details
Commencement Date	<p>Works shall commence within the period of September to December 2026, with the exact commencement date to be confirmed by the Employer upon issuance of the Letter of Acceptance / Notice to Proceed. The Contractor shall be ready to mobilise within 10 days of receipt of the official Notice to Proceed, which shall be issued within the said period.</p> <p>It is expressly clarified that the determination of the deployment/commencement date shall be at the sole discretion of NHIT. The Contractor or any service provider shall have no right to question, dispute, or claim against the timing of such deployment or commencement as decided and communicated by NHIT.</p>
Conditions for Commencement	<ul style="list-style-type: none"> - Submission and approval of Performance Security. - Submission and approval of Insurance Policies as per contract. - Mobilization of key personnel and equipment as per the approved deployment plan. - Submission and approval of the Detailed Work Program.
Completion Date	<p>2 Years plus 2 years extendable.</p>
Milestones / Key Project Dates if applicable	<p>The contractor shall adhere to the milestone schedule outlined in the contract. Failure to meet key milestones may result in penalties or liquidated damages as per the contract.</p>

3.2. Contract Duration

(RFP Clause 4; Annexure [C2] of RFP – Scope of Work; Clause 3 of GCC)

Description	Details
Total Contract Duration	<p>2 + 2 year.</p>
Construction / Execution Period	<p>2 + 2 year.</p>
Defects Liability Period	<p>N.A.</p>
Extension of Time (EOT) Conditions	<p>The contractor may apply for an EOT in case of force majeure, employer delays, or other justifiable reasons as per contract provisions. Approval of an EOT is subject to the Engineer's review and Employer's approval.</p>
Penalty for Delay	<p>If the contractor fails to complete the works within the stipulated duration or delays mobilization beyond the agreed timeline, liquidated damages (LD) shall be levied as per contract terms.</p>

3.3. Defects Liability Period (Ref: GCC Clause 29)

Description	Details
Defects Liability Period (DLP) Duration	<p>(12 months) from the issuance of the Completion Certificate.</p>
Scope of Contractor's Obligations	<ul style="list-style-type: none"> - Rectification of any defects, deficiencies, or failures occurring during the DLP. - Conducting necessary inspections and maintenance to ensure the durability of the work. - Responding to defect notifications within the stipulated timeframe.
Response Time for Rectifications	<p>Minor defects – 10 Days Major defects – 20 Days Critical defects affecting safety – Immediate action required</p>

National Highways Infra Trust

 National Highways Infra Trust	Contract Data Sheet	Doc No.: NHIT/FY25-26/RFP/ Incident Management-02
--	----------------------------	---

Description	Details
Retention Money / Security Release	[06] % deduction from each bill, Subject to up to a maximum of 5% of the contract value. Refundable within 30 days after rectifying all defects which were identified on DLP period. Retention money can be released on submission of equivalent value of Bank Guarantee (BG).
Failure to Rectify Defects	If the contractor fails to rectify defects within the stipulated time, the Employer may engage a third party to perform the necessary rectifications at the contractor's cost, deducted from retention money or performance security.

3.4. Substantial Completion: (Ref. GCC Clause 23)

Description	Details
Definition of Substantial Completion	The stage when the Works, as per the Contract, are completed except for minor pending works or defects that do not materially affect the intended use of the project.
Conditions for Substantial Completion Certification	<ul style="list-style-type: none"> - All major works are completed as per the approved drawings and specifications. - The project is functional and fit for its intended purpose. - Testing & commissioning (if applicable) is successfully conducted. - Safety and operational compliance are ensured. - Any pending minor rectifications or works do not hinder functionality.
Issuance of Substantial Completion Certificate (SCC)	Upon fulfilment of the above conditions, the Engineer/Employer shall issue the Substantial Completion Certificate , marking the transition to the Defects Liability Period (DLP).
Responsibility of the Contractor Post-Substantial Completion	<ul style="list-style-type: none"> - Rectification of minor pending works within the specified timeframe. - Adhering to defect rectification obligations during the DLP. - Handover of As-Built Drawings, O&M Manuals, and other necessary documents.
Final Acceptance and Completion Certification	The Final Completion Certificate shall be issued after the Defects Liability Period, provided all outstanding issues are resolved to the Employer's satisfaction.

This section is structured **in accordance with GCC Clause 23** and provides a clear framework for determining substantial completion.

4. Instructions to Bidders (ITB)

4.1. Definitions & Interpretations (Ref. RFP Clause 2.1)

All terms shall have the meanings assigned to them as per the **Request for Proposal (RFP)** and **General Conditions of Contract (GCC)**. In case of any inconsistency, the order of precedence shall be as defined in the contract documents.

4.2. Earnest Money Deposit (EMD) (Ref. RFP Clause 2.4.1)

EMD Details	Description
EMD Amount	For Ambulance - 30,000/vehicle For RPV Rs. 15,000/Vehicle For Crane Rs. 15,000/Vehicle
Mode of Submission	Demand Draft /BG
Validity of EMD	90 days.

National Highways Infra Trust

 National Highways Infra Trust	<h2>Contract Data Sheet</h2>	Doc No.: NHIT/FY25-26/RFP/ Incident Management-02
--	------------------------------	---

Refund Timeline for Unsuccessful Bidders	Within [30] days of bid finalization.
Forfeiture Conditions	<ul style="list-style-type: none"> - Withdrawal or modification of bid during validity period. - Failure to sign the contract or submit performance security within the stipulated time.
Exemptions (if applicable)	As per the provisions of the RFP, MSME/Startups may be exempted – N.A.

4.3. Electronic Submission (If Applicable) (Ref: RFP Clause 2.3.2.8)

Description	Details
Portal for Submission	https://mt.tyasuite.com/#/login?public_reg=04f58dac471d1d0faaf64535d127893b85780b0f7645b3164d75fca164a14af824ed37fd34ebfa471de822f7ed82b5731194d2b15acb00867ab4d8d0a2e58e7XIX8XMQRp6YEO4tomjhtOvKBTk8EFahHxNU8jOFKdn0C1KUn8SEap3bjeivM2Ft8t+zkHqSwbn5QC2gMpVTopDQB2r1joYyc1aSSVMsIaRRyfWbM3cVrQ+XQZv6N5Ny1A2f1Oq382feeBxbfuFDPYNC5dQvXyqtN/g1BxtMSRel/Kllp4kJK8Yonvd62U5JU
Submission Deadline	As above clause 2.5
File Format & Size Restrictions	Not Applicable
Digital Signature Requirement	Not required however Bidders are required to submit their technical and financial bids in both physical and online way.
Helpdesk/Support Contact	Attached herewith as Annexure C10 – Process of Online Bid Submission. (Please use the Google Chrome browser for bid submission)

5. Eligibility & Qualification Criteria

Note: Bidders who have submitted bids against Tender No. NHIT/FY25-26/RFP/Incident Management, uploaded on the NHIT website on 27th February 2026, are not required to submit the Technical Proposal again. Such bidders may submit only the Financial Proposal.

Bidders who were found technically qualified in the above-mentioned tender shall be considered pre-qualified bidders for this RFP as well.

5.1. Financial Eligibility (Ref: RFP Clause 3.6.1 & Clause 12.1)

Criteria	Requirement	Reference
Minimum Cumulative Turnover	₹ [2,00,00,000] (last 03 financial years)	Ref: RFP Clause 3.6.1
Net Worth Requirement	₹ [Should be Positive]	Ref: RFP Clause 3.6.1
Solvency Certificate	Not Applicable	Ref: RFP Clause 3.6.1
Financial Data Submission Format	Not Applicable	Ref: RFP Clause 12.1

5.2. Work Experience (Ref: RFP Clause 3 & Clause 12.2)

Criteria	Requirement	Reference
Executed Work Value Requirement	₹ 2,00,00,000 in last 03 years	Ref: RFP Clause 3.2.3

National Highways Infra Trust

 National Highways Infra Trust	Contract Data Sheet	Doc No.: NHIT/FY25-26/RFP/ Incident Management-02
--	----------------------------	---

Similar Experience	i. Minimum 03 Years' Experience in Providing Incident Management Services. ii. Minimum Incident Management Vehicle owned by the Bidder – Minimum 05 Vehicles	Ref: RFP Clause 3.2.1
Civil Works Experience	N.A.	Ref: RFP Clause 3.3.3
Electrical Works Experience	N.A.	Ref: RFP Clause 3.3.4
Ongoing Projects (if required)	As per RFP Clause 2.2.7.3 & 12.2	Ref: RFP Clause 2.2.7.3; 12.2
Work Experience Data Submission Format	As per Clause 12.2	Ref: RFP Clause 12.2

5.3. Joint Venture or Consortium – Not Allowed (For RFP Clause 2.2.1).

6. Project Information (Ref: RFP Clause 4)

6.1. Time for Completion & Key Dates (Ref: GCC Clause 3.1 & Clause 4; RFP Annexure [C2])

The Contractor shall commence the work within the stipulated time as per the Letter of Acceptance (LoA) and shall ensure completion within the contract duration specified below.

Particulars	Details
Date of Commencement	Within 10 days of NTP, as per the above Cl. 3.1
Contract Duration	2 year + 2 years extendable
Scheduled Date of Completion	2 year + 2 years extendable

6.2. Milestones & Performance Benchmarks (RFP Clause 4; Annexure [C2])

The Contractor shall achieve the following key milestones within the stipulated timeline:

Milestone No.	Description	Timeline from Start Date
Milestone 1	Not Applicable	Not Applicable
Milestone 2	Not Applicable	Not Applicable
Milestone 3	Not Applicable	Not Applicable

Failure to meet these milestones shall be subject to penalties or liquidated damages, as per Clause 30 of GCC.

6.3. Project Scope (Ref: RFP Clause 4; Annexure [C2])

As per attached annexure C2

6.4. Project Location & Length (Ref: RFP Clause 4.2.4; Annexure [C4])

Description	Details
Project Name	NHIT/FY25-26/RFP/Incident Management-02
Highway Stretch	As above.
Chainage	Refer Annexure C4
Total Length	Refer Annexure C4
State/Region	Refer Annexure C4

6.5. Technical Specifications & Standards (Ref: RFP Clause 11.4.2, Section 6.3, Annexure [C7])

The works shall conform to the following applicable standards:

- i. **Relevant MoRTH Specifications for Pavement Repair & Rehabilitation works.**
- ii. **Relevant IRC (Indian Roads Congress) Codes & Guidelines.**
- iii. **Relevant Indian Standard (IS) Codes.**

National Highways Infra Trust

 National Highways Infra Trust	<h2>Contract Data Sheet</h2>	Doc No.: NHIT/FY25-26/RFP/ Incident Management-02
--	------------------------------	---

iv. **Employer's Requirements as specified in the RFP and subsequent updates on NHIT website.**

7. Financial Proposal (Ref: RFP Clause 9)

7.1. Payment Schedule (Ref: RFP Clause 9.2 & GCC Clause 14)

The Contractor shall be paid as per the approved payment schedule, ensuring compliance with contractual obligations and performance benchmarks.

Particulars	Details
Milestone-Based Payments	Yes
Bill of Quantities-Based Payment	No
Advance Payment (if applicable)	Not Applicable
Retention Money (Ref: GCC Clause 14.5)	[06] % deduction from each bill, Subject to up to a maximum of 5% of the contract value. Refundable within 30 days after rectifying all defects which were identified on DLP period. Retention money can be released on submission of equivalent value of Bank Guarantee (BG).
Interim Payment Certificates (IPCs)	Issued upon verification of completed work as per BoQ (monthly)
Final Payment	Released after successful completion and final acceptance of works
Deductions (if any)	Includes retention, penalties, or adjustments for non-conformance
GST Payable Extra	[Yes]
Mode of Payment	[NEFT / RTGS]
Payment Processing Time	Payment shall be made only after submission and verification of the invoice by the authorized representative.
Taxes & Duties (excluding GST)	As applicable, to be deducted at source (TDS, etc.)

7.2. Bills of Quantities (BoQ) (Ref: RFP Clause 9.3)

Measurement and payment shall be made strictly as per the approved **Bill of Quantities (BoQ)** and contractual provisions.

Particulars	Details
Measurement & Payment Terms	As per BoQ
Verification Process	Joint measurement by Engineer & Contractor before certification
Variation in Quantities	Subject to approval and rate adjustments as per contract

8. Performance & Security Documents (Ref: RFP Clause 10.1 & 10.2)

8.1. Performance Security (Ref: GCC Clause 33 & RFP Clause 10.1)

The Contractor shall submit a **Performance Security** as per the details below:

Particulars	Details
Performance Security Amount	05 % of contract Value
Mode of Submission	Bank Guarantee (BG)
Validity Period	[26] months from the Date of Completion
Issuing Bank Criteria	Scheduled Commercial Bank as per RFP guidelines
Invocation Conditions	Upon default, non-performance, or contract termination

8.2. Advance Payment Security (Ref: RFP Clause 10.2)

National Highways Infra Trust

 National Highways Infra Trust	Contract Data Sheet	Doc No.: NHIT/FY25-26/RFP/ Incident Management-02
--	----------------------------	---

If an **Advance Payment** is applicable, the Contractor shall provide a **Bank Guarantee (ABG)** as security for the same:

Particulars	Details
Advance Bank Guarantee (ABG) (If applicable)	Equal to the Advance Payment sanctioned
Format for Bank Guarantee	As per Annexure [B3]
Validity Period	Until full adjustment of advance
Adjustment Mechanism	Deduction from Interim Payments as per the agreed recovery schedule
Bank Guarantee Issuing Authority	Nationalized/Scheduled Commercial Bank

9. Payments, Financials, and Security

9.1. Insurance Requirements (Ref: GCC Clause 12)

The Contractor shall procure and maintain the following insurances during the contract period:

- i. **Contractor's All-Risk Insurance** covering loss or damage to works, plant, and materials.
- ii. **Public Liability Insurance** covering third-party claims due to contractor's operations.
- iii. **Worker's Compensation Insurance** as per applicable labor laws.
- iv. **Any other insurance required as per Employer's requirements.**

9.2. Currency of Payment (Ref: RFP Clause 2.2.14.3)

All payments shall be made in INR, as per contract terms.

9.3. Total Contract Price (RFP Clause 2.1; 2.3)

Total Contract Value	N.A.
-----------------------------	------

- i. The contract price is inclusive/exclusive of applicable taxes and duties, as defined in the Agreement.
- ii. **GST shall be payable extra, as applicable.**

9.4. Liquidated Damages for Delay (Ref: GCC Clause 30)

- i. If the Contractor fails to achieve mobilization as well as completion timelines, **liquidated damages (LD)** shall be levied at **0.5% of contract value per day of delay**, subject to a maximum of **[05] %** of the contract price. If the Contractor fails to achieve mobilization as well as completion timelines, LD shall be levied.
- ii. Delay beyond the maximum LD cap shall be liable for further penalties or contract termination, as per Employer's discretion.
- iii. In the event of non-payment of liquidated damages as stipulated herein, the Employer shall be entitled to levy an interest @18% per annum till dated of realization of liquidated damages, the said sum shall be payable by sole fact of the delay without the need for any previous notice or any legal proceedings, of proof of damages, which shall in all cases be considered as ascertained. The Employer may, without prejudice to any other method of recovery, deduct the amount of such liquidated damages from any moneys in its hand due for payment to the contractor. The payment of deduction of such damages shall not relieve the contractor of its obligation to complete the work or form any other of its obligations and liabilities under the contract.

10. Supplementary Information for Bidders

National Highways Infra Trust

 National Highways Infra Trust	Contract Data Sheet	Doc No.: NHIT/FY25-26/RFP/ Incident Management-02
--	----------------------------	---

Particulars	Details	Reference Clause
Clarifications Issued After Pre-Bid	Any amendments or clarifications post pre-bid meeting will be officially communicated through an addendum.	RFP Clause 11.5 & 2.5
Addendums & Corrigendums	Any modifications to the RFP will be issued through formal addenda. Bidders must regularly check the employer's website/portal.	RFP Clause 11.6
Bidder's Responsibility for Site Conditions	Bidders must examine site conditions before submission. No claims due to lack of site awareness will be entertained.	RFP Clause 2.2.21.4.
Bid Withdrawal & Modification Rules	Conditions under which bidders may withdraw or modify their bids before the submission deadline.	RFP Clause 2.3.2.5.
Confidentiality & non-disclosure	Bidders must not disclose any project-related confidential information. Breach may lead to disqualification.	RFP Clause 2.2.18; 15; GCC Clause 32; 36.3
Disqualification Criteria	Grounds for bid rejection (e.g., non-compliance, blacklisting, fraudulent practices).	RFP Clause 3.8
Financial Proposals	Bidders may submit their proposal for any number of projects or Vehicles mentioned in this RFP, but must ensure that number of vehicles in that particular category is sufficient as per requirements of that project.	
Number of Engaged Contractors	The SPVs under the NHIT shall have the authority to determine the allocation of projects to contractors. The SPVs at its discretion may choose to award each project separately to different contractors or collectively to a single contractor.	

11. Abstract of Relevant Contractual Information

Item No.	Description	Details	GCC Clause
Dispute Resolution and Governing Law			
1	Dispute Resolution Mechanism	Process for resolving disputes (e.g., Arbitration, Mediation).	GCC 18
2	Governing Law	Jurisdiction and applicable laws governing the contract.	GCC 17
Force Majeure and Termination			
3	Force Majeure Clause	Conditions under which force majeure applies and the process for notifying.	GCC 19
4	Termination Clauses	Conditions under which the contract can be terminated by either party.	GCC 20
Health, Safety, Environment, and Quality Management			
5	Health, Safety, and Environmental Management	Contractor's responsibilities regarding health, safety, and environmental protection.	GCC 11
6	Quality Management	Quality control measures, adherence to standards, and quality certifications required.	GCC 8
Contractor's Obligations			

National Highways Infra Trust

 <small>National Highways Infra Trust</small>	Contract Data Sheet	Doc No.: NHIT/FY25-26/RFP/ Incident Management-02
---	----------------------------	---

Item No.	Description	Details	GCC Clause
7	Contractor's Obligations	Contractor's primary responsibilities including timelines, material standards, and compliance.	GCC 4
8	Contractor's Personnel	Details of the required personnel qualifications and roles.	GCC 5
Subcontracting, Risk, and Documentation			
9	Subcontracting and Assignment	Conditions under which the contractor may subcontract or assign parts of the contract.	GCC 6
10	Risk Management	Contractor's obligations for identifying, monitoring, and mitigating risks.	GCC 7
11	Project Documentation and Reporting	Reporting requirements, documentation submission during project progress.	GCC 27
12	Change Management	Procedures for changes in project scope, cost, or time.	GCC 16
Warranties and Maintenance			
13	Warranties and Guarantees	Warranties regarding the quality and performance of work/materials.	GCC 24
14	Maintenance and Performance Standards	Specific maintenance standards and performance benchmarks.	GCC 28
Performance Monitoring, Reporting, and Penalties			
15	Performance Monitoring and Reporting	Requirements for monitoring contractor performance and reporting during execution.	GCC 15
16	Performance Penalties	Mechanisms for imposing penalties for underperformance.	GCC 15
Intellectual Property			
17	Intellectual Property Rights	Ownership and use of designs, deliverables, or documents created during the project.	GCC 36.3
Miscellaneous Provisions			
18	Compliance with Local Laws & Regulations	Contractor shall comply with labor laws, environmental regulations, and tax obligations.	GCC 4; 13; 17
19	Language of Communication	All official communication, reports, and documents shall be in English.	GCC 31.5
20	Amendments & Modifications	Any modifications to the contract must be agreed upon in writing by both parties.	GCC 16
21	Contractor's Obligations in Case of Termination	Responsibilities in case of contract termination, including project handover.	GCC 3.4; 20

12. Project-Specific Annexures (Ref: RFP Clause 18)

The list of project-specific annexures, along with their respective formats and requirements, is detailed in RFP Clause 18 "List of Annexures". Bidders shall refer to Clause 18 (List of Annexures) for complete details and ensure compliance with the submission requirements.

Scope of Work for RPV

1. SCOPE OF SERVICES

- 1.1 The Service Provider shall provide the following Incident Management Vehicles (IMVs/RPVs) for the designated roads under the "Project Name." The detailed scope of work, including specifications, equipment, and responsibilities related to the Incident Management Vehicles, is defined in this Contract. The Service Provider shall ensure that each Incident Management Vehicle remains fully equipped, functional, and operational in accordance with the Contract requirements for the entire duration of the Contract.
- 1.2 The Service Provider shall provide Route Patrol Vehicles (RPV) strictly in accordance with the latest IRC: SP:84-2019 (Annexure-C of IRC: SP:84-2019) and NHA Policy Guidelines No. 12.36/2024 dated 12.12.2024, as and when required by the Client's Representative for the purpose of the Project. Each RPV shall be deployed with four (4) drivers per vehicle. The cost of fuel shall be Included and under a part of the Service Provider's scope under this item

Incident Management Scope									
S. No.	Project Name	Toll Plaza Location	Toll Plaza Name	Section	Section Wise Chainage			Vehicle Nos Details	Scope of Monthly Running
					From	TO	Length	RPV	RPV (Km)
1									
2									

- Fuel Consumption the Service Provider shall deploy an Incident Management Vehicle (RPV) capable of achieving an average fuel efficiency of not less than 14 km/ litre for each Highway Route Patrol Vehicle.
- Notwithstanding anything contained elsewhere in this RFP, the clause stipulating that "The vehicle shall run minimum 5 km daily (even for dry run), to be eligible for monthly payment" shall stand deleted in its entirety and shall have no force or effect hereafter.
- The contractor shall provide a Route Petrol Vehicle conforming to BS-VI emission standards

2. PETROL VEHICLE SPECIFICATION (RPV) AS PER IRC SP-84:2019 & NHA / Policy Guidelines / Road Safety / 2024 Policy Circular No. 12.36/2024 dated 12th December 2024

Every Route Patrol Vehicle (RPV) should adhere to the minimum specifications as described below:

2.1 Vehicle type

- (i) RPV should be a large Sport Utility Vehicle (SUV) or Multi Utility Vehicle (MUV) with a seating capacity of minimum 4 people including the driver.
- (ii) RPV should be able to accelerate from 0 km/h to 80 km/h within 20 seconds when tested in accordance with IS: 11851-1986.
- (iii) The Route Patrol Vehicle (RPV) should be capable of maintaining stable and controlled movement in case an emergency situation demands high speed movement.
- (iv) The RPV should be a new vehicle and should not have covered more than 2000 km (mileage) at the time of procurement. Once a vehicle has either exceeded 3,00,000 kilometers or has

been in operation for three years, whichever occurs first, it shall be replaced with new RPV.

- (v) Rear or trunk of RPV shall be of closed ceiling with cabinet shelves and dedicated space of each equipment and inventory. The shelves shall be so designed that accessing any equipment shall be quick, easy and with least dependency on any other equipment. Cabinet design with dimensions shall be as shown in Figure 2. It may be noted that closed cabinet storage-based design has been prepared to accommodate all proposed inventory in RPV and to facilitate easy accessibility during incident handling. It may further be noted that the dimensions mentioned in Figure 2 are minimum requirements to accommodate the inventory. Improvisation in the shared design / layout arrangement shall not be conducted, unless otherwise approved by the concerning authority based on project specific / region specific requirements.

2.2 **External Appearance: -**

Emblems, Logo, Marking & Colour Scheme:

To maintain uniformity across the country, the external appearance of the RPV shall be as shown in **Figure 1**.

- (i) Complete body exterior shall be painted with PU base 2K paint, white in colour with red stripe pattern as shown in the image below. The placement, font style, size, and overall dimensions of the logo, authority name, and emergency number shall be followed as shown in Figure 1 and as described below.
- RPV shall have **“RAJMARG SAATHI”, “NHAI”, “SPV” logo, texts “NHAI” & “HIGHWAY PATROL UNIT”** written on the vehicle as shown in Figure 1.
 - On the storage cabinet: Diameter of logos (NHAI and RAJMARG SAATHI) shall be 550 mm. Font height of letter “HIGHWAY PATROL UNIT” shall be 60 mm.
 - On the passenger doors: Diameter of logos (NHAI and SPV) shall be 500 mm. On the bonnet: Diameter of “NHAI” logo shall be 550 mm.
 - Font height of “NHAI” written shall be 200 mm.
 - Font Style: English: Arial Black & Font Style Hindi: KrutiDev 040
 - Font colour shall be followed as per the colour scheme shown in Figure 1.
 - Rear of the vehicle shall be provided with fluorescent yellow and red stripe pattern using reflective paint as shown in the image. The stripes shall slope downward and away from the centre line of the vehicle at an angle of 45°. Each stripe shall be 6 inches wide and arranged in an alternating red and yellow pattern. Additionally, retroreflective striping inside vehicle doors is essential to maintain conspicuity and to alert passing drivers when the doors are opened.

- 2.3 **Lighting and Illumination:** -The RPV shall be equipped with fog lamps, warning lights, a roof-mounted rear bar light and a front LED bar light with siren, in addition to standard vehicle indicators, headlamps, and tail lamps.

(i) Warning Lights:

The warning light system shall be installed externally as per the specified arrangement, colour, and size detailed in the image provided. These lights shall alternate between red and blue colours, flashing at a rate of 60 to 90 flashes per minute. To help other drivers recognize the RPV's operational status, distinct emergency lighting patterns shall be used to differentiate between a

moving and stationary vehicle. This can be achieved through various strobe patterns, light configurations, and colour sequencing.

(ii) Roof-Mounted Rear Bar Light:

The roof-mounted rear bar light shall be programmed to flash at 60 to 90 flashes per minute in alternating red and blue colours. All light assemblies must be made of weatherproof materials to prevent electrolysis and corrosion between the light housing and the vehicle body.

- 2.4 **Siren with Public Address System:** - A high-quality combination electronic siren with Integrated Public Addressing System of minimum 100W (PMPO) shall be provided. The siren's controls should have full-range volume control and should permit the following sounds: Manual, Wail, and Yelp. The siren sweep rate should be 10-18 cycles per minute. The microphone should be of a noise-cancelling type. Siren/Speakers shall not protrude beyond the face of the bumper or bumper guards if provided therein. The control panel for this system should be fixed at a suitable location in the driver compartment.
- 2.5 **Cameras for Intelligent Support-** A dashboard camera with GPS with AI video analytics fixed on the front dashboard positioned to capture the view of the highway and identify road defects like cracks and potholes respectively shall be installed in the RPV. It should possess advanced capabilities beyond mere recording. Dashboard camera to be equipped with AI-powered object detection and classification algorithms to automatically identify and categorize various elements of the road environment, including vehicles, pedestrians, road signs, and infrastructure.

Minimum Specifications for Cameras:

- 2 Megapixel, 1920×1080 at 30fps, FOV (D:125, H:105, V:58)
- Operating Environment: Temperature: -20 to +70 degrees Celsius, humidity: 10% to 90%, atmospheric pressure: 860 mbar to 1080 mbar
- Memory Storage: minimum 256GB
- Support: Wi-Fi, 4G (minimum), GPS, 2GB RAM, G-sensor (3-axis acceleration sensors)
- Camera shall support IR capabilities

This data can then be used to create a comprehensive inventory database of road features, aiding in infrastructure management, route planning, and hazard identification.

3. DRIVER FOR ROUTE PETROLLING VAN-

- 3.1 The Service Provider shall be fully responsible for ensuring the availability of 4 (four) drivers, including relievers with each RPV as per the latest IRC: SP 84-2019 (Annexure C of IRC SP 84 2019) and NHA policy guidelines no. 12.36/2024 dated 12.12.2024, as and when required by the Client's representative, for the purpose of the Project. This Contract shall not apply to services provided to any third-party vehicle hire services unless the Client agrees in writing.

3.2 DRIVER FOR RPV

(A) Details of Driver

- (i) 1 driver should be appointed per shift per vehicle.
- (ii) Employees appointed should have a valid license to drive an vehicle
- (iii) Employees appointed should be able to **read/write and maintain logbooks.**

- (iv) Basic training of employees should include fields such as
- Vehicle driving along multiple shifts
 - Minor repairing of vehicle
 - Vehicle and equipment use and maintenance
 - Radio and communication
 - Defensive driving
 - Extinguishing vehicle fires
 - Work site protection
- (v) Employees appointed should, from time to time, undergo certified training declared by the Authority related to Incident Management within the given stipulated timelines to continue his/her services.

(B) Responsivity of Driver

- (i) Regularly check and maintain the patrol vehicle, ensuring it is in good working condition (fuel levels, engine condition, tire pressure, lights, horn (forward and reverse), wipers, etc.).
- (ii) Report any vehicle issues or required repairs to supervisors promptly.
- (iii) Offer basic assistance, such as jump-starting stranded vehicles and assisting with flat tires, fuel, etc.
- (iv) Assist emergency responders and the highway surveillance in-charge in en-route patrol activities.

4. EQUIPMENT AND INVENTORY IN ROUTE PETROLLING VAN AS PER IRC SP-84:2019 & NHAI / Policy Guidelines / Road Safety / 2024 Policy Circular No. 12.36/2024 dated 12th December 2024

Following are the list of equipment and specifications of each to be kept in working condition in every RPV:

(i). Tracking Equipment

- Automatic vehicle tracking system with GPS technology for tracking vehicle's current location; GPS Technology shall be in accordance with AIS-140 requirement of Vehicle Tracking System (VTS) of NHAI.

(ii). Communication Equipment

- 1 Nos Mobile communication device with camera and internet connectivity.
- 1 Nos Two-way radio device with antenna or better technology for mobile communication, for communication with on-road control room units. It should have a sufficient range to communicate in the entire section with sufficient battery life (12 hours+). This is mandatory along highways having telephonic blackspot locations.
- 1 Nos Siren with Public Address System as mentioned in the vehicle description.
- Dashboard camera with GPS and AI video analytics fixed on the front dashboard.

(iii). General Surveillance Equipment

- White color high intensity torch lights with two sets of spare batteries (2 Nos).
- Orange color reflective safety jacket and gum boots (3 Nos sets, 1 for each attendant).
- Helmet with whistle attached on side (3 Nos sets, 1 for each attendant).
- Rain suit with reflective strips (3 Nos, 1 for each attendant).
- 5L capacity liquid containers for carrying fuel along with a funnel (2 Nos, one for petrol and diesel).

- Drinking water container with 5L capacity (1 No).
- Rope of minimum 20 m length (1 No) suitable to tow LMV.
- Red color reflective flags made of santoor fabric, dimension 600 × 900 mm (5 Nos).
- Baton lights, red and green color, 21-inch length and 1.25-inch diameter (2 Nos).

(iv). Vehicle Repairing Equipment

- Leather gloves (3 Nos, 1 for each attendant).
- Rubber gloves (3 Nos, 1 for each attendant).
- 20-ton hydraulic jack, able to attain a maximum height of at least 300 mm (1 No), suitable for cars as well as medium / large trucks.
- Heavy duty steel towing chain of minimum 1.5 m length (1 No).
- Portable tyre inflator pump with tyre gauge capable of filling tyres up to pressure of 50 psi; suitable for cars, buses and light trucks (1 No). Tyre sealant (500 ml).
- Starter leads with multi-meter for making connections with external power source (1 pair).
- Tow bar for towing purposes, 1.3 m long (1 No).
- Mechanical toolkit with equipment like hammer, fencing pliers, mallet, ratchet wrench set, screwdriver set, battery brush, etc.
- Tow hook in the front as well as rear.

(v). Extrication & First Aid Equipment

- 1 hydraulic/electric portable hand cutter and spreader combined tool, capable of cutting vehicle parts, metal structure, steel plates. Maximum cutting force > 250 kN, Spreading force > 25 kN, Opening distance of blades > 150 mm
- 4 wooden wedges – rectangular wooden blocks of minimum dimension 150 × 120 × 60 mm for stabilizing light and heavy vehicles.
- Woollen blankets (2 Nos).
- First aid kit (1 No) containing:
 - 24 small, 12 medium, 12 large, sterilized dressings, 12 large, sterilized burn dressings. 12 packets (15 cm) of sterilized cotton wool.
 - 200 ml bottle of cetricimide solution (I) or suitable antiseptic solution, 1 (200 ml) bottle of mercurochrome (2%) solution in water. 1 (120 ml) bottle of sal-volatile having the doses and made of administration indicated on the label.
 - Pair of scissors.
 - 1 role of Adhesive plaster: 1 roll (6 cm × 1 m) and 2 rolls (2 cm × 1 m).
 - 12 pieces of sterilized eye pads in separate sealed packets.
 - A Bottle containing 100 tablets (325 mg) of aspirin or any other analgesic.
 - 12 roller bandages (10 cm wide) and 12 roller bandages (5 cm wide).
 - 1 tourniquet.
 - A Supply of suitable splints and 3 packets of safety pins.
 - Kidney tray.
 - Snake bite lancet.
 - 1 (30 ml) bottle containing potassium permanganate crystals.
 - 1 Copy of first aid leaflet issued by the Directorate General.
 - 6 triangular bandages.
 - 2 pairs of sterilized latex hand gloves.

- Burn gel packets and sterile burn dressings.
- Sufficient number Eye wash bottles filled with distilled water or suitable liquid clearly indicated by a distinctive sign which shall be visible at all times.
- 4% xylocaine eye drops, boric acid eye drops, soda bicarbonate eye drops.
- CPR face shield, pocket mask, disposable gloves.
- Hand sanitizer.
- Tweezers, digital thermometer, instant cold packs.
- Pain relievers (Ibuprofen, Acetaminophen), antihistamine tablets (for allergic reactions), aspirin.

(vi). Scene Management Equipment

- Minimum 20 reflective cones of 750 mm each, should be orange in colour with retro-reflectors white band and a heavy rubber base with minimum possibility of being displaced by wind/vehicular traffic..
- 4 kg dry powder fire extinguisher, ISI marked & conforming to IS 13849:1993 or latest (2 Nos).
- Hard bristle broom (1 No).
- Shovel (1 No).
- Signboard with chevron arrows on both sides and mechanism to stand by itself (6 Nos), as shown in Fig-3 (size 900 × 900 mm).

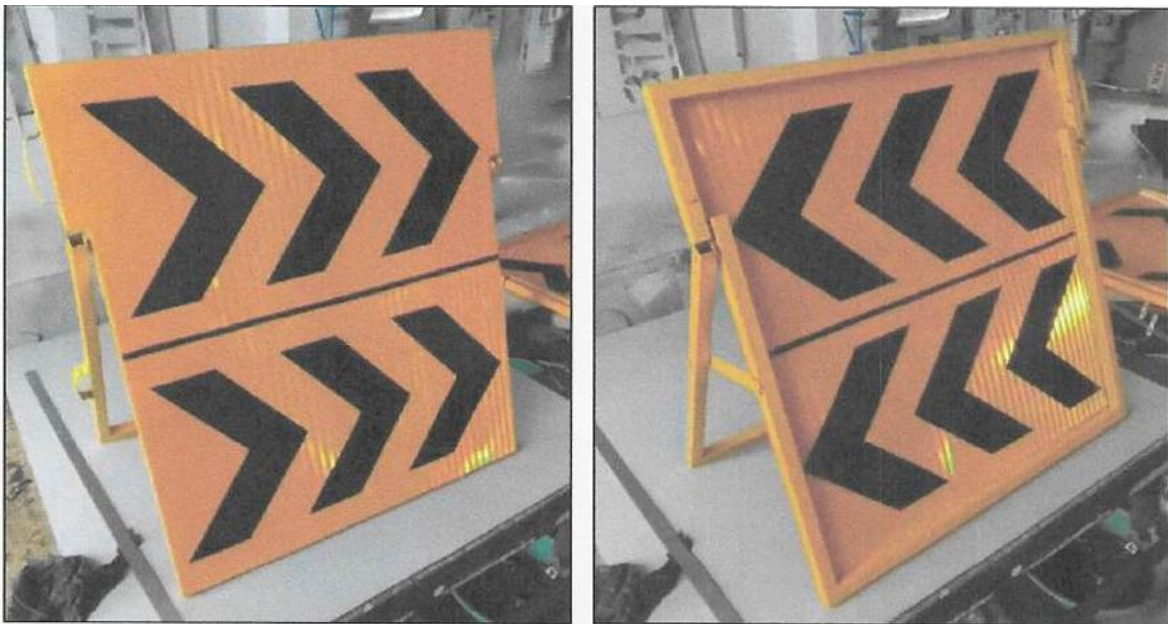

Figure 3: Modular sign board with Front and Back view

- 2 foldable tripods to raise the height of first signboard depending on traffic characteristics on the highway.
- 6 numbers of flashing light for fixing on each signboard to improve visibility whenever signboard is installed while handling the incident.

- Solar/battery-based flashing LED light with clamp/magnetic arrangement for fixing on signboard (minimum 12 hours backup and minimum visibility distance of 500 m). few image for reference are shown alongside



- Red colour reflective tape of 4-inch width (1 roll) and caution tape (1 roll).
- 3 pairs of safety glasses and masks for protection from glass debris/airborne dust.
- 10 kg sealed bucket with lime or cement inside.
- 5 kg sandbag to handle oil spills on the highway.
- Animal hook, 1.3 m long (1 No).
- Rock salt bag of 5 kg with cool box, dead body cover/bag for smaller dead animals up to 50 kg.

The branding and recognition pattern of RPV described above should resemble with the one shown in the sketches below:



Figure 1: Side and Rear view of the RPV

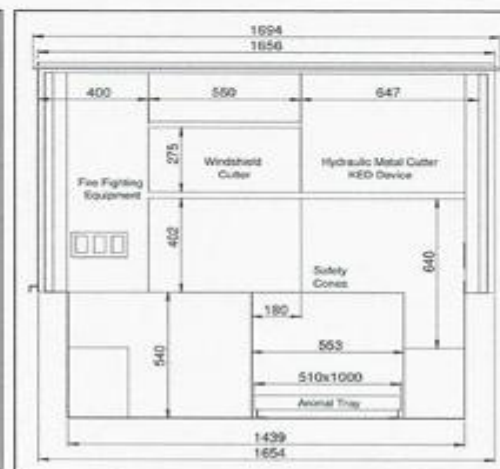
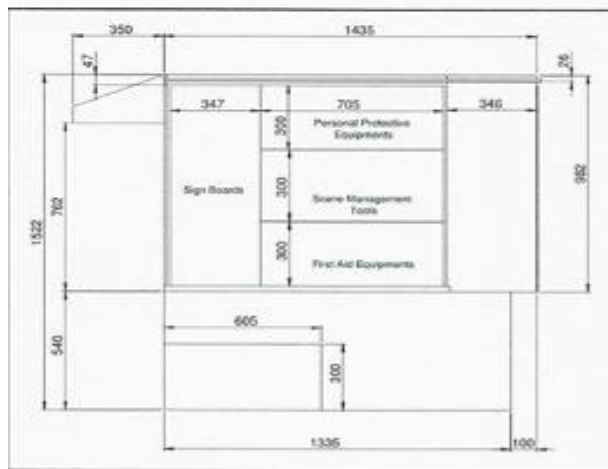
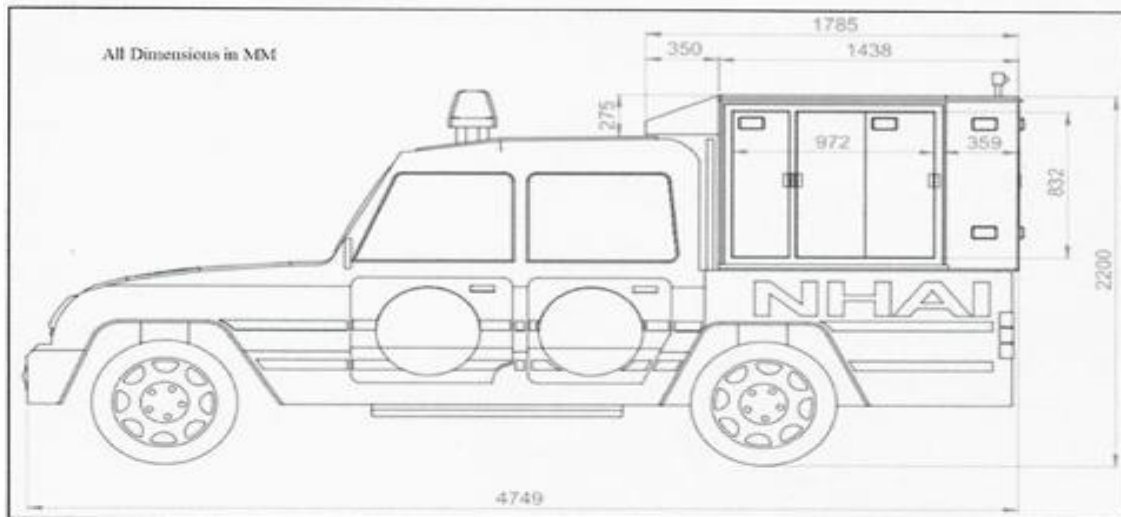

Figure 2: Cabinet-Storage Based Route Patrolling Vehicle Arrangement

5. TERMS OF PAYMENT

- 5.1 The Service Provider shall maintain and update logbooks indicating trip details, kilometers run, working hours, breakdowns, and maintenance days, duly signed by the concerned Client's personnel who are using the Vehicle/Client's representative.
- 5.2 The logbook shall also record the quantity, rate and date of each fuel refill.
- 5.3 The logbook and accident register shall be submitted to the Client's representative as and when required.
- 5.4 The Service Provider shall submit monthly invoices, duly approved by the Project Manager of the Project along with the logbook and VTS Report/GPS report for certification by the Client on or before the 5th (fifth) day of each month for the Services rendered in the previous month.
- 5.5 At the time of submission of the bill, the fuel Consumption sheet shall be submitted along with the invoice.
- 5.6 If the Service Provider is an MSME vendor, it shall be clearly mentioned on the invoice that they are an MSME vendor. A copy of the valid Udyam Certificate shall be attached with each payment request.
- 5.7 The Client shall make payments within 45 (forty-five) days from receipt of an undisputed invoice with all necessary supporting particulars from the Service Provider.
- 5.8 All payments shall be subject to applicable tax deductions. Payments will be released net of GST, which will be paid upon proof of GST payment.
- 5.9 All payments made to the Service Provider under this Contract shall be made in INR, as per invoices which are approved and duly certified by the Client.
- 5.10 The rate/ contract value includes the lubricants, periodic and regular maintenance costs, overheads, profits and any other incidental costs relating to the Incident Management Vehicles. All wear and tear costs, along with related expenses (maintenance, oil topping, etc.) shall be borne by the Service Provider.
- 5.11 The rate/ contract value also includes drivers' & Helper wages, overtime charges (if any), accommodation, food, mobile phone expenses, insurance cost, depreciation, and any incidental costs.
- 5.12 If any taxes are to be levied under the Applicable Law, the same shall be charged over and above the agreed amount at actuals. GST amounts in invoices shall be due and payable only upon receipt of proof of GST payment/ verification of the same on the GST portal.
- 5.13 The Client shall be entitled, at any time, to request a detailed bifurcation of the monthly fees charged, including a breakdown of costs for drivers/operators.
- 5.14 Escalation is not applicable to RPV services under this contract.

1. HR Compliance

1.1 HR non-compliance with HR requirements, an amount equivalent to 9% of the value of work executed in the current bill (excluding GST) shall be withheld from the invoice, applicable from the second bill onwards, subject to a maximum cap of 5% of the total Contract Value.

However, no HR-related withholding shall be applicable to the current bill, if HR compliance has been duly submitted and accepted in the last paid invoice, the HR compliance amount shall not be withheld in the current bill.

1.2 For Incident Management contracts, HR compliances shall be monitored on a quarterly basis. In case HR non-compliance continues for six consecutive months, the contract shall be liable for termination.

1.3 The Service Provider shall submit the following with respect to the compliances along with the monthly invoice:

Sr.no	Type of compliance	Frequency of compliance and submission	Type of Document
1	Pay sheet	Monthly	Service Provider shall submit a declaration stating that it had complied with minimum wages
2	PF remittance details (ECR) (Challan)	Monthly	Consolidated challan & declaration
3	ESI remittance details (Challan)	Monthly	Consolidated challan & declaration (if applicable)
4	Insurance policy (GPA copy/WC- if ESI not applicable)	One time	Copy of WC policy –only in case of non-ESI area.
5	Insurance policy for public liability	One time	Cover will be by the Client, but responsibility, indemnity and impact with Service Provider.
6	Vehicle insurance	Yearly	Copy of insurance

1.4 The Service Provider shall provide backup documents regarding labour compliance, if any, as and when asked by the Client, within [3 (three)] working days of such request.

2. DEFICIENCY AND PENALTY

2.1 Service provider shall provide a replacement of the Incident Management Vehicle of similar facility whenever the agreed Incident Management Vehicle is not available due to any reason whatsoever. An amount of INR 5,000/- (Indian Rupees Ten Thousand Only) per day would be

deducted for providing a replacement Incident Management Vehicle of lesser make or capacity, for more than 1 (one) day in any month for each Incident Management Vehicle.

- 2.2 **Fuel Charges Variance Clause** - If the RPV runs less than the fixed KMs then the deduction will be calculated on the standard of the Rs.14/Km, and in case ambulance runs more than the fixed KMs then the extra amount will be paid to the on the standard of the Rs.14/Km.
- 2.3 **Shortfall in Deployment of Incident Management Vehicle Driver** In case of non-manning of the Incident Management Vehicle, the Service Provider shall deploy the manpower as specified in the Contract Agreement. For any missed shift, a penalty of INR 1,000 per shift shall be levied and deducted from the invoice until the manpower shortfall is fully rectified
- 2.4 **Not Wearing Uniforms**- In case any driver/helper is found not wearing the prescribed uniform and/or not carrying a valid ID card during duty, a penalty of INR 100 per person per shift shall be levied and deducted from the invoice.
- 2.5 **Carrying ID cards**- The driver and helper shall mandatorily carry identity card during duty hours.
- 2.6 **Non-manning Equipment**-
- All consumables shall be replenished before the next use. A minimum inventory level, as specified in the Contract, shall be maintained at all times. The Client shall provide suitable space at each toll plaza along the Project stretch for parking and stationing of the Vehicles.
 - Faulty equipment shall be repaired or replaced within 2 (two) working days.
 - Damaged (non-working) Vehicles shall be replaced within 6 (six) hours by the Service Provider

In case of non-manning or non-availability of any equipment as specified in the Contract Agreement, and after a prior notice of seven (7) days issued from the Site as per Clause 4 (i), (ii), (iii), (iv), and (vi), a penalty of INR 400 per day shall be levied and deducted from the invoice.

2.7 **Misconduct of staff**-

In the event of any misconduct by the Service Provider's staff:

- First instance: A written warning shall be issued.
- Second instance: The concerned staff member shall be suspended from duty for a period of seven (7) days.
- Third instance: The Client reserves the right to terminate the Contract as per the terms and conditions of the Agreement.

Scope of Work for Crane

1. SCOPE OF SERVICES

- 1.1 The Service Provider shall provide the following Incident Management Vehicles (IMVs/Crane) for the designated roads under the "Project Name." The detailed scope of work, including specifications, equipment, and responsibilities related to the Incident Management Vehicles, is defined in this Contract. The Service Provider shall ensure that each Incident Management Vehicle remains fully equipped, functional, and operational in accordance with the Contract requirements for the entire duration of the Contract.
- 1.2 The Service Provider shall be fully responsible for ensuring the availability of 4 (four) drivers/operators, including relievers with each Farana Crane (30 MT capacity) and Tow Away Crane (Minimum 20 MT) as per the latest IRC: SP 84-2019 as and when required by the Client's representative, for the purpose of the Project. The cost of fuel shall be included and in part of the Service Provider's scope under this item

Incident Management Scope											
S. No.	Project Name	Toll Plaza Location	Toll Plaza Name	Section	Section Wise Chainage			Vehicle Nos Details		Scope of Monthly Running	
					From	TO	Length	Crane	Towing Vehicle	Crane (Hr.)	Towing Vehicle (Km)
1											
2											

- Fuel shall be provided by Service Provider shall deploy an Incident Management Vehicle capable of achieving an average fuel efficiency of not less than 4.5 litre/Hr. for each Farana Crane and fuel efficiency of not less than 5 litre/Hr. for each Towing Crane.
- The contractor shall provide a Farana Crane and Tow Way Vehicle conforming to BS-VI emission standards
- Notwithstanding anything contained elsewhere in this RFP, the clause stipulating that "The vehicle shall run minimum 5 km daily (even for dry run), to be eligible for monthly payment" shall stand deleted in its entirety and shall have no force or effect hereafter.

2. FARANA CRANE AND TOW WAY CRANE SPECIFICATION

- 2.1 Capacity -Minimum lifting capacity: 30 MT for Farana Crane and 20 MT for Tow Way Crane
- 2.2 Chassis & The crane shall be a heavy-duty truck-mounted crane fitted with an engine compliant with BS-VI emission norms. The engine shall have adequate power suitable for highway incident recovery operations. The vehicle shall be equipped with a safety locking system to ensure stability during lifting operations and shall include forward and reverse horn, warning lights, and an audible alarm.

3. DRIVER FOR FARANA CRANE AND TOW WAY CRANE

(A) Details of Driver

- (i) 1 driver should be appointed per shift per vehicle.

- (ii) Employees appointed should have a valid license to drive a Farana Crane and Towing Crane vehicle
- (iii) Employees appointed should be able to read/write and maintain logbooks.
- (iv) Basic training of employees should include fields such as
 - Vehicle driving along multiple shifts
 - Minor repairing of vehicle
 - Vehicle and equipment use and maintenance
 - Radio and communication
 - Defensive driving
 - Extinguishing vehicle fires
 - Work site protection
- (v) Employees appointed should, from time to time, undergo certified training declared by the Authority related to Incident Management within the given stipulated timelines to continue his/her services.

(B) Responsivity of Driver

- (i) Regularly check and maintain the Crane, ensuring it is in good working condition (fuel levels, engine condition, tire pressure, lights, horn (forward and reverse), wipers, etc.).
- (ii) Report any vehicle issues or required repairs to supervisors promptly.
- (iii) Offer basic assistance, such as jump-starting stranded vehicles and assisting with flat tires, fuel, etc.

4. TERMS OF PAYMENT

- 4.1 The Service Provider shall maintain and update logbooks indicating trip details, kilometers run, working hours, breakdowns, and maintenance days, duly signed by the concerned Client's personnel who are using the Vehicle/Client's representative.
- 4.2 The logbook shall also record the quantity, rate and date of each fuel refill.
- 4.3 The logbook and accident register shall be submitted to the Client's representative as and when required.
- 4.4 The Service Provider shall submit monthly invoices, duly approved by the Project Manager of the Project along with the logbook and VTS Report/GPS report for certification by the Client on or before the 5th (fifth) day of each month for the Services rendered in the previous month.
- 4.5 At the time of submission of the bill, the fuel Consumption sheet shall be submitted along with the invoice.
- 4.6 If the Service Provider is an MSME vendor, it shall be clearly mentioned on the invoice that they are an MSME vendor. A copy of the valid Udyam Certificate shall be attached with each payment request.
- 4.7 The Client shall make payments within 45 (forty-five) days from receipt of an undisputed invoice with all necessary supporting particulars from the Service Provider.
- 4.8 All payments shall be subject to applicable tax deductions. Payments will be released net of

GST, which will be paid upon proof of GST payment.

- 4.9 All payments made to the Service Provider under this Contract shall be made in INR, as per invoices which are approved and duly certified by the Client.
- 4.10 The rate/ contract value includes the lubricants, periodic and regular maintenance costs, overheads, profits and any other incidental costs relating to the Incident Management Vehicles. All wear and tear costs, along with related expenses (maintenance, oil topping, etc.) shall be borne by the Service Provider.
- 4.11 The rate/ contract value also includes drivers' & Helper wages, overtime charges (if any), accommodation, food, mobile phone expenses, insurance cost, depreciation, and any incidental costs.
- 4.12 If any taxes are to be levied under the Applicable Law, the same shall be charged over and above the agreed amount at actuals. GST amounts in invoices shall be due and payable only upon receipt of proof of GST payment/ verification of the same on the GST portal.
- 4.13 The Client shall be entitled, at any time, to request a detailed bifurcation of the monthly fees charged, including a breakdown of costs for drivers/operators.
- 4.14 Escalation is not applicable to Crane/Tow way Crane services under this contract.

5. HR Compliance

- 5.1 HR non-compliance with HR requirements, an amount equivalent to 9% of the value of work executed in the current bill (excluding GST) shall be withheld from the invoice, applicable from the second bill onwards, subject to a maximum cap of 5% of the total Contract Value.
- However, no HR-related withholding shall be applicable to the current bill, If HR compliance has been duly submitted and accepted in the last paid invoice, the HR compliance amount shall not be withheld in the current bill.
- 5.2 For Incident Management contracts, HR compliances shall be monitored on a quarterly basis. In case HR non-compliance continues for six consecutive months, the contract shall be liable for termination.
- 5.3 The Service Provider shall submit the following with respect to the compliances along with the monthly invoice:

Sr.no	Type of compliance	Frequency of compliance and submission	Type of Document
1	Pay sheet	Monthly	Service Provider shall submit a declaration stating that it had complied with minimum wages

2	PF remittance details (ECR) (Challan)	Monthly	Consolidated challan & declaration
3	ESI remittance details (Challan)	Monthly	Consolidated challan & declaration (if applicable)
4	Insurance policy (GPA copy/WC- if ESI not applicable)	One time	Copy of WC policy –only in case of non-ESI area.
5	Insurance policy for public liability	One time	Cover will be by the Client, but responsibility, indemnity and impact with Service Provider.
6	Vehicle insurance	Yearly	Copy of insurance

5.4 The Service Provider shall provide backup documents regarding labour compliance, if any, as and when asked by the Client, within **[3 (three)]** working days of such request.

6. DEFICIENCY AND PENALTY

6.1 Service provider shall provide a replacement of the Incident Management Vehicle of similar facility whenever the agreed Incident Management Vehicle is not available due to any reason whatsoever. An amount of INR 5,000/- (Indian Rupees Ten Thousand Only) per day would be deducted for providing a replacement Incident Management Vehicle of lesser make or capacity, for more than 1 (one) day in any month for each Incident Management Vehicle.

6.2 **Non- Manning of Fuel-** In case the average fuel consumption is not maintained as specified in the Contract Agreement, the corresponding amount shall be deducted from the invoice at the prevailing fuel rate. 500rs/Hrs.

6.3 **Shortfall in Deployment of Incident Management Vehicle Driver** - In case of non-manning of the Incident Management Vehicle, the Service Provider shall deploy the manpower as specified in the Contract Agreement. For any missed shift, a penalty of INR 1,000 per shift shall be levied and deducted from the invoice until the manpower shortfall is fully rectified.

6.4 **Not Wearing Uniforms-** In case any driver/helper is found not wearing the prescribed uniform and/or not carrying a valid ID card during duty, a penalty of INR 100 per person per shift shall be levied and deducted from the invoice.

6.5 **Carrying ID cards-** The driver and helper shall mandatorily carry identity card during duty hours.

6.6 Misconduct of staff-

In the event of any misconduct by the Service Provider's staff:

- First instance: A written warning shall be issued.
- Second instance: The concerned staff member shall be suspended from duty for a period of seven (7) days.
- Third instance: The Client reserves the right to terminate the Contract as per the terms and conditions of the Agreement.

Scope of Work for Ambulance

1. SCOPE OF SERVICES

- 1.1 The Service Provider shall provide the following Incident Management Vehicles (Ambulance) for the designated roads under the "Project Name." The detailed scope of work, including specifications, equipment, and responsibilities related to the Incident Management Vehicles, is defined in this Contract. The Service Provider shall ensure that each Incident Management Vehicle remains fully equipped, functional, and operational in accordance with the Contract requirements for the entire duration of the Contract.
- 1.2 The hiring of "2-Patient Capacity" Rescue Ambulances shall strictly conform to the minimum specifications prescribed under IRC: SP-84-2019, Section-12, Clause-12.11 and Annexure-D of IRC: SP-84-2019, read in conjunction with NHAI Circular No. RW/G-23012/01/2019-W&A (Pt. III) dated 09.02.2021 and 22.03.2021, and NHAI Policy Guidelines No. 12.36/2024 dated 12.12.2024, as amended from time to time.
- Each Rescue Ambulance shall be deployed with four (4) drivers and four (4) EMTs/Paramedics per vehicle. The cost of fuel shall be included and shall be part of the Service Provider's scope under this item.

Incident Management Scope									
S. No.	Project Name	Toll Plaza Location	Toll Plaza Name	Section	Section Wise Chainage			Vehicle Nos Details	Scope of Monthly Running
					From	TO	Length	Ambulance	Ambulance (Km)
1									
2									

- The contractor shall provide a Ambulance conforming to BS-VI emission standards
- Notwithstanding anything contained elsewhere in this RFP, the clause stipulating that "The vehicle shall run minimum 5 km daily (even for dry run), to be eligible for monthly payment" shall stand deleted in its entirety and shall have no force or effect hereafter.

2. AMBULANCE SPECIFICATION AS PER IRC:SP:84-2019

2 Patient Capacity Rescue Ambulance

2 Patient Capacity' rescue ambulance should adhere to the minimum specifications as described below:

2.1 Vehicle characteristics

General Construction

- The road rescue ambulance shall comply with homologation requirements given in standards notified under CMVR 1989 and the AIS-125 Code. Wherever, there is difference in the homologation requirements given in other standards notified under CMVR 1989 and AIS-125 code, the requirements of AIS-125 code will be applicable.
- The rescue ambulance vehicle shall be a Swaraj Mazda/Tempo traveler or equivalent which should be a new vehicle and should not have covered more than 2000 km at

the time of procurement (from date of first registration).

Performance requirements

- The road rescue ambulance loaded to the permissible gross vehicle weight shall be able to accelerate from 0 km/h to 70 km/h within 40s, when tested in accordance with IS: 11851-1986

2.2 **Electrical requirements**

- **General**

Electrical installations shall comply with those Clauses of IEC 60364-7-708 which are applicable to rescue ambulances.

- **Battery and alternator**

Batteries shall be positioned to allow maintenance without removing the battery from its securing device. The construction of the battery and all connections to it shall be such as to prevent any possibility of an inadvertent short circuit. Additional batteries may be required to power the medical devices carried on board and the intended use of the rescue ambulance. In such cases, the manufacturer shall ensure optimal charging of the additional batteries without any impact on the primary vehicle battery. The additional circuit shall not draw current more than as specified by the manufacturer.

- Indicative Capacity/Power (These values are given as a broad guideline only. The manufacturers may alter them based on vehicle characteristics and operational requirements) should be as per the below mentioned table:

Indicative Capacity/ Power requirements		
Additional Battery(ies) (if deployed)	Nominal Voltage 12V	80Ah
	Nominal Voltage 24V	63Ah (2x12V)
Alternator Power		700W

- When the engine is idling, electrical stability should be maintained between electrical load and alternator output. In order to achieve, this it may be necessary to fit an electrical load prioritization device to the vehicle
- Manufacturer shall give declaration regarding the certified capacity of the electric system of the vehicle model in the following format:

Sr No.	rescue Ambulance type	Additional electric Load of medical equipment's permissible (Watts)
1	C/ Basic Life Support	XXX

- This shall be prominently displayed in the patient compartment at an appropriate location. Further each electrical socket provided in the patient compartment should be permanently labelled as regards its voltage and amperage.
- **Electrical Installation**
 Recessed externally mounted power connector to enable external power to be provided for operations such as the following:
 - (a) Charging battery (ies).
 - (b) Operating medical devices, when installed.
 - (c) Operating a stand-alone patient compartment heater, when installed.
 - (d) Operating an engine pre-heater, when installed.
- The connector for 220/240 V, shall be a male connector and not interfere with the electrical and mechanical safety.
- It shall be not possible to start the engine whilst it is connected to an external 220/240 V power supply unless an automatic mechanical disconnection is fitted. If no automatic mechanical disconnection is fitted, the connector shall

be on the driver's side. The 220/240 V circuit shall be protected either by an "earth leakage device" with a maximum setting of 30 mA or by a separated transformer. If the protection is given only by an "earth leakage device" there shall be a label near the plug that reads as follows: "CAUTION! CONNECT ONLY TO AN AUTHORISED SOCKET."

- The patient's compartment shall be fitted with a minimum 4 number of connections. For these connections a permanent power supply shall exist.
- Any additional electrical systems fitted to the base vehicle shall be separated from the base vehicle electrical system and the body or chassis shall not be used as an earth return for additional circuits. All circuits in the additional system(s) shall have separate overload protection. Overload protection may consist of either fuses or so called Electronic Management Control systems. All circuits shall be well defined and cables clearly marked at the connection points and at a maximum of 1m intervals along its length.
- The system shall have enough circuits and be so constructed that when/if a circuit fails all illumination and medical technical equipment can be switched to an alternative power source
- The wiring and, where applicable conduits, shall withstand vibrations. No wiring shall be located in or pass through conduit intended for medical gas installation. The wiring shall not be loaded higher than that stated by the wire manufacturer
- Where there are different voltage systems, the connections shall be non-interchangeable

2.3 Vehicle Body

Fire Safety

- All interior materials shall comply with the flammability requirements specified in IS: 15061, as notified under CMV (A) R, 1989 though the standard does not cover rescue ambulance in the scope

Fitment of fire extinguisher

- The rescue ambulance shall be equipped with Two fire extinguishers of 2 Kg each.

Minimum loading capacity

The minimum loading capacity of at least 2 stretcher facilities in the patient compartment. Serious casualties/ patients must not be transported on patient compartment seat without use of stretcher & proper restraining support provided to the patient

Partition Wall

- Full partition wall or a partition wall with a door or a window shall separate the driver's compartment from the patient's compartment. Where a door is fitted, it shall be secured against opening if the road rescue ambulance is in motion.
- One or two windows with a minimum separation of 100 mm shall be provided in the partition wall made of material complying with the requirements of CMVR. The windows shall allow direct visual contact with the driver. The opening area of the window shall have a maximum area of 0,12 m². It shall be secured against self-opening and shall have an adjustable blind or other means of preventing the driver being disturbed by the light of the patient's compartment.

openings (Doors, Windows, emergency exits)

General

- (a) The driver seat shall comply with the requirements of AIS:023-2005 or IS:15546-

2005 as applicable and notified under CMVR. There shall be a minimum of two openings – one at the rear (door/tailgate) and one at the side (door/window) of the patient's compartment. All openings shall have seals to protect against the ingress of water and dust.

- (b) All openings shall comply with the minimum dimensions set out in the following table

		Dimension in mm
Side Opening (optional)	Height	1300
	Width	660
Rear Opening	Height	1300
	Width	660

Door

- (a) Each external door of the patient's compartment shall be fitted with Doors a security system which enables the following:

- lock and unlock from inside without use of a key;
- lock and unlock from outside with use of a key;
- Unlock from the outside using a key when the door is locked from the inside.

- (b) Note: This security system may be integrated with an optional central locking system. The patient's compartment doors shall be capable of being positively restrained in the open position. An audible or visual signal shall warn the driver when any door is not completely closed when the vehicle is in motion. The key can be a mechanical or non-mechanical device

Window

- (a) In the patient's compartment, there shall be a minimum of two external windows. There shall be one on each side or one on the side and other at the rear. The windows shall be positioned or screened to ensure patient's privacy when required. Windows shall be fitted with safety glasses complying with the requirements of IS:2553 specified under Rule 100 of CMV(A)R, 1989.

Stretcher loading

- (a) Loading area requirements shall be in accordance with the following table.

Loading Angle (Strecher)	Maximum	160 a
Loading Height Stretcher	When the patient is manually loaded or unloaded on the stretcher, the centre of the stretcher handles shall be no more than 975 mm above ground level. The maximum height of either the floor or the loading holding assembly above ground level shall not exceed 900 mm at net vehicle mass plus loose equipment.	
The loading angle (fig. 1) should be kept as low as possible.		

- (b) Where a ramp or lift is installed between ground level and vehicle floor level, it shall be covered with an anti-slip surface and capable of taking a constant load of 350 kg. In the event of a power failure the loading device shall be capable of being operated manually

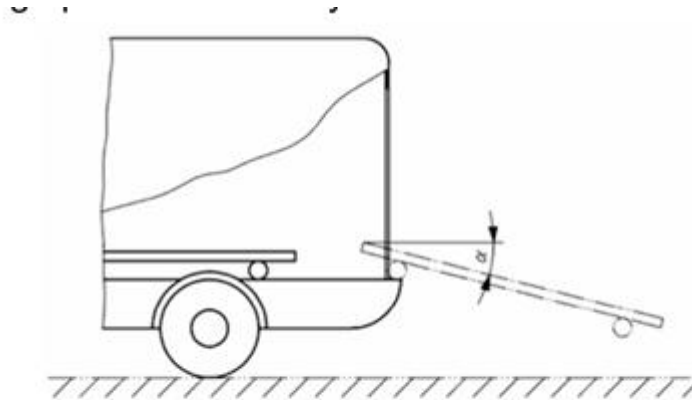

Fig. 1 Loading angle for the stretcher

2.4 Patient's Compartment

General

- The patient compartment should have minimum internal dimensions of at least 2500 mm (length) x 1800 mm (width) x 1800 mm (height)
- The patient's compartment shall be designed and constructed to accommodate the medical devices listed in the equipment table. The width of the patient compartment after installation of cabinets, etc. shall provide 40 ± 15 cm clear aisle walkway between the main stretcher/undercarriage and the base of squad bench/attendant seats, with the main stretcher located in the street side (non-centered) position.
- The length of the Patient Compartment shall provide at least 64 cm and not more than 76 cm of unobstructed space at the head of the primary patient, when measured from the face of the backrest of the Doctor's/Paramedic's Seat to the forward edge of the stretcher.
- The ceiling, the interior side walls and the doors of the patient's compartment shall be lined with a material that is non-permeable and resistant to disinfectant. The edges of surfaces shall be designed and/or sealed in such a way that no fluid can infiltrate. If the floor arrangement does not allow fluids to flow away, one or more drain with plugs shall be provided. Exposed edges that could come into contact with the occupant's hands, legs, head etc., during normal use shall have a radius of curvature of not less than 2.5 mm except in the case of projections of less than 3.2 mm, measured from the panel. In this case, the minimum radius of curvature shall not apply provided the height of the projection is not more than half its width and its edges are blunted. All installations in the patient compartment above 700 mm from floor level shall not have sharp exposed edges and shall terminate in rounded edges. Sharp edges shall meet the requirements of IS:15223 for M1 and AIS:047 for M2 as amended from time to time. Medical equipment and their holding devices (for example stretchers, platforms, suction units etc.) are excluded. Drawers should be secured against self-opening and where lockers are fitted with doors that open upwards they should be fitted with a positive hold open mechanism
- The rescue ambulance should be equipped with a lockable drugs compartment with security lock. Floor coverings shall be chosen that will provide adequate grip for the attendant including when wet and should be durable and easy to clean.
- The rescue ambulance should also be fitted with a hand-holding device positioned above the stretcher. The hand-holding device shall be positioned along the longitudinal axis. If the patient's compartment is to be equipped with a non-foldable chair, space shall be provided with a width of at least 600 mm measured at elbow height and a ceiling height above the

seat squab of at least 920 mm. Vehicle maintenance equipment (e.g. Spare wheel and Tools) shall be placed such that accessing them does not cause inconvenience to the patient

Patient and attendant seating

- The minimum number of patient and attendant seats should be as per the following table

Minimum number		2
Position (s)	On one side of the stretcher	1
	On one side of the stretcher 2/3 end	1
Positions (s) at head of stretcher		-

Patient and attendant seat dimensions

- Patient and attendant seat dimensions shall be minimum of 381 mm X 381 mm per seat. Seats fitted in the patient compartment shall be installed in either forward/sideward/rear-facing positions and shall be fitted with Two Point (Lap Belt) or Three Point Retractable Safety Belts (preferred for forward/rearward facing seats) in conformance with IS:15140-2003. Head restraints shall be fitted as applicable and in accordance with AIS-023:2005 or IS:15546-2005. Backrests shall be constructed to a minimum dimension of 300 mm × 100 mm.

Patient compartment environmental equipment

- The patient compartment shall be heated, ventilated, and air conditioned as required in accordance with the criteria specified hereto.

Air conditioning criteria

- The cooling system should be such that, given an outside and inside temperature of 32°C, the cooling down to at most 27°C in the patient's compartment should not take longer than 15 min. After 30 min. a temperature of at most 25°C should be reached.
- The inside temperature should be measured in the centre of the patient compartment and at the mid-point from the cooling outlets (if several outlets are available). The installation of the system shall not encourage exhaust gases entering the patient's compartment.

Heating

- If the heating system is provided, the system shall be such that given an outside and inside temperature of -10°C, the heating up to at least +15°C shall not take longer than 45 min. The inside temperature shall be measured in the centre of the patient compartment and at the midpoint from the heater outlets (if several outlets are available). The installation of the system shall not encourage exhaust gases entering the patient's compartment

Interior lighting

- Natural colour balance lighting shall be provided as set out in the table below.
- Note: The colour temperature of the light will change the appearance of skin and organs. Therefore, it is important that the interior lighting is suitable for patient care during transport. Although it may not be necessary in rescue ambulance use to define "daylight" or "natural colour balance" in a more exact way other than the colour temperature. The colour temperature of the interior lights should be minimum 4000 Degrees Kelvin

Patient's compartment illumination – maximum intensity Lux	
Patient Area (Stretcher)	150
Surrounding Area	50

- Light levels shall be measured along the central longitudinal axis of the stretcher at the head, mid-point and foot position with the stretcher in its normal position for transportation in the rescue ambulance

Interior noise level

- The interior noise level in the patient compartment shall comply with requirements of AIS:020. During the test, the Siren of the rescue ambulance shall be kept in the Off position.

Ingress of dust and rainwater

- All doors, windows and hatches shall not allow ingress of dust and rain water when in the fully closed position, when tested in accordance to IS:11739 1986 as amended from time to time, for recording dust ingress in automotive vehicles, and when tested in accordance to IS:11865-2006 as amended from time to time, for water proofing test for automobiles.

Mounting systems

- Permanent seats and their anchorages in the patients' compartment, designed for use by patients and attendants when the rescue ambulance is in motion, shall comply with the requirements of IS:15546-2005 (for M1 category vehicles) and AIS:023-2005 (for other than M1 category vehicles).
- All items e.g. medical devices, equipment and objects normally carried on the road rescue ambulance shall be restrained, installed or stowed to prevent them becoming a projectile when subjected to accelerations/decelerations of 10 g in the forward and rearward directions.
- When subjected to these accelerations/decelerations, the distance travelled by an equipment or an item shall not endanger the safety of persons on the road rescue ambulance.
- After being subjected to these accelerations/decelerations
 - (a) no items shall have sharp edges or endanger the safety of persons in the road rescue ambulance;
 - (b) the maximum distance the stretcher and any item attached to either the holding assembly or stretcher may travel shall be no more than 150 mm. The displacement of the patient during the test may exceed 150 mm
 - (c) it shall be possible to release all persons in the road rescue ambulance without the use of equipment not carried on the road rescue ambulance.
 - (d) All tested lockers, rails and non-dedicated storage locations or storage devices shall be labelled to show the total maximum permissible weight allowed

Testing of maintain Systems and Fixations of the equipment in the Patient's Compartment

- Verification of conformity to fixation and restraint systems shall be carried out when the stretcher(s)/medical device(s) and holding assembly are placed in the mean position of all possible positions available.
- The sample submitted for testing shall be identical to, or shall have the same characteristics and behaviour as, the production item or vehicle during the test.
- **Note:** Care shall be taken that no internal or external additional reinforcement through the rig will modify the behaviour during the test.
- The stretchers and chairs shall be loaded with a dummy (as specified in IS:15140-2003), which shall then be secured with the restraint system.
- The head end of the stretcher shall be fixed in a position of **15° measured from the horizontal**. The lying area of the stretcher tray assembly (holding assembly) shall be in a horizontal position.
- The stretcher shall be fixed on the stretcher's holding assembly. The sedan chair, when provided, shall also be fixed in its holder.
- Dynamic tests shall be carried out with the appropriate stretcher(s) or medical device(s) installed or stowed in the holding system(s), or with weights having the same mass distribution and dimensions corresponding to the mass and dimensions of the stretcher(s) and device(s) intended to be installed or stowed in the holding system.
- In case of dynamic testing, the dynamic test shall be carried out using a patient compartment assembly or a relevant part of the construction approved by the notified body, and the following test method shall be applied:
 - The test assembly shall be accelerated/decelerated in the longitudinal and transverse vertical directions in accordance with the figure below.
 - The impact speed shall be between **30 km/h and 32 km/h**

- Test weights for use in lockers shall be sandbags with masses in kilogram increments, with a tolerance of **+0% / -0%**.

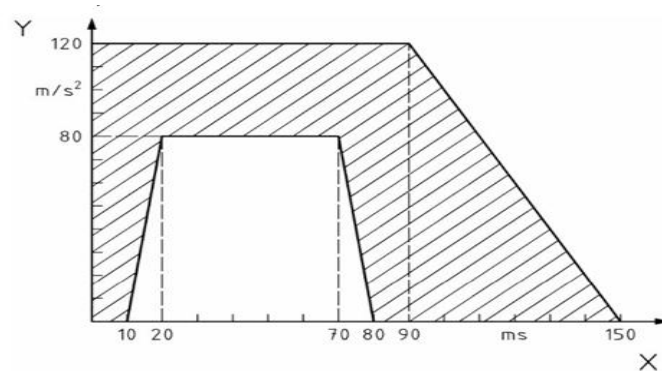

Fig. 2 Acceleration Impulse

2.5 Medical On- equipment

Devices & board

- **Medical Devices Storage**

All equipment required for a set procedure shall be stored in a specified location. Essential equipment required for use outside the vehicle shall be easily accessible via normally used doors. All equipment shall be securely and safely stowed to prevent damage or injury whilst the vehicle is in motion.

- **Requirements for medical Devices**

General

The device shall be designed for use in mobile situations and in field applications. If a medical device is designated as "portable", which is mandatory for use inside a rescue ambulance (except main stretcher, pickup stretcher, vacuum mattress & long spinal board). It shall be in accordance with IEC:60601-1 and shall

- be possible to be carried by one person
- have its own built in power supply (where relevant)
- be capable of use outside the vehicle
- be possible to be carried by one person have its own built in power supply (where relevant) be capable of use outside the vehicle be placed preferably along the street side wall of the patient compartment or along the ceiling ensuring the minimum possible distance to be connected to the patient without hindering the movement of personnel around the main stretcher.

Temperature

- Unless otherwise marked on the device, the device shall function as described in the following two points, when brought back to room temperature (20°C) after storage in temperatures ranging from -30°C to 70°C.
- Unless otherwise marked on the device, the device shall function throughout the temperature range from 0°C to 40°C.
- Unless otherwise marked on the device, the device shall function for at least 20 min. when placed in an environment at -5°C after storage at room temperature (20°C).

Humidity and ingress of liquids

- Devices shall comply with ISO:60601-1 and with particular device standards of the series ISO:60601-2 where applicable.

Mechanical strength

- **general:** Where there are not more stringent requirements for mechanical strength in particular devices standards exists, then the following mechanical strength requirements shall apply to medical devices for use in road rescue ambulances.
- **Vibration and bump:** After vibration tests and bump test in accordance Vibration & Bump test, the maintain system and device shall function within the tolerances specified by the manufacturer
- **free fall:** If the medical device is fixed, as defined in ISO:60601-1, it is exempted from the free fall test. Devices which are taken out of holders and/ or carried by hand shall be submitted to the Free Fall Test according to the Free Fall Test (mentioned subsequently) and shall then function within the tolerances specified by the manufacturer.
- Note: A medical device may consist of fixed and loose components, the Free Fall Test applies to the loose components only.

Fixation of devices

- The device shall be restrained by means of a fixation system.
- The fixation system(s), maintain system(s) or storage system(s) shall hold the device to withstand accelerations or decelerations of 10 g longitudinal (forward, backward), 10 g transverse (left, right) and 10 g vertical.
- Terminal units and electrical socket outlets shall not be used as part of the fixation system.
- If rails systems are used, they shall comply with ISO:19054. Note: Rail systems consist of e.g. rail supports, rails, rail clamps, equipment mount holders, equipment mounts, equipment pin holders and equipment pins.

Electrical Safety

- All devices shall be selected and mounted so that no harmful influence to the electrical supplies results

User interface

- Buttons, switches, indicators and controls shall be easily accessible and visible. SI units (except for blood pressure and airway pressure) and standardized graphical symbols where applicable shall be used

Gas installation

- All the components should be certified as per ISO/TC 121/SC6 and ISO:15001-2003 as "Compatibility of Medical Equipment with Oxygen"
 - (a) Source of supply the source of supply shall consist of one or more of the following, as per the requirement of the source supplies in the different types of road rescue ambulances
 - (i) Gas in cylinders, e.g. Oxygen
 - (ii) Any other compressed medical gas as required for treatment and therapy of patients
 - (iii) Vacuum system.
 - (b) Note: All the components of the source of supply should be certified as per ISO:7396.
 - (c) All compressed gas cylinders except for sizes up to 2.2 L Water Capacity, must be stored and used in an upright position with the valve end up. Only special compressed gas cylinders designed and certified for use in a horizontal position can be placed in that position.
 - (d) The valve of the compressed gas cylinder when is at a height of more than 1500 mm from the ground level, the cylinder compartment should be provided with an retractable/foldable/flushed/enclosed foot step to permit the user to stand comfortably to access the cylinder valve at the time of changing the

- cylinders.
- (e) The cylinder compartment should have facility to place the regulators safely at the time of replacing empty cylinders and fitting filled ones.
 - (f) Rescue ambulances should never be operated with lesser number of cylinders as specified in equipment table

System design

- (a) The rescue ambulance whenever fitted with a stationary oxygen system, shall have all the essential components and accessories required for two sets of piped oxygen system which shall include as a minimum:
 - (i) One no. Pressure Regulator for each of the supply sources (stationary as well as portable)
 - (ii) Low pressure, electrically conductive, hose approved for medical oxygen.
 - (iii) Oxygen piping concealed and not exposed to the elements, securely supported to prevent damage, and be readily accessible for inspection and replacement.
 - (iv) Oxygen piped to a self-sealing duplex oxygen outlet station for the primary patient with a minimum flow rate of 100 LPM at the outlet.

In addition to the above, the ambulance shall have hospital type piped medical oxygen system (manifold) capable of storing and supplying medical grade oxygen. The system should comprise of an oxygen cylinder manifold as specified, a cylinder changing wrench, chained and clipped with/within the oxygen cylinder compartment; a pressure regulator; oxygen piping approved for medical oxygen; a duplex oxygen outlet station with quick-disconnect interface for the primary patient and a second duplex oxygen outlet station with quick-disconnect interface for the secondary patient. A medical grade oxygen pressure regulator with inlet filter & static outlet pressure of 4.12 bars /60 psi shall be provided at the cylinder manifold. It shall include a pressure gauge, an inlet filter, a safety relief valve; a locking mechanism to prevent settings from being inadvertently changed; shall maintain accurate readings and calibrations during ambulance operation and not be affected by the temperature conditions. The manifold should have oxygen cylinders of B or D size only (minimum one D & one B type cylinder/equivalent). An adapter to refill the cylinders from a bulk cylinder should be provided.

- (b) The patient cabin shall have a digital display panel for oxygen supply status. The display panel should be certified for use with Medical Oxygen and should have three individual values displayed to constantly indicate the pressure level of both the cylinders as well as the distribution pressure level. The digital displays should show the actual pressure measured by three individual digital pressure sensors as per the pressure level under monitoring (one each for both the cylinders and one for the line pressure)
- (c) The changing from one cylinder to the other should not affect the distribution pressure in any way and this change over should occur as fully automatic operation
- (d) The rescue ambulance shall be supplied with an emergency oxygen outlet for each of the stationary oxygen system available on any of the walls of the patient compartment easily accessible to the patient head end and connected directly at the output of the pressure regulator of the stationary oxygen system ensuring that any fault in the oxygen distribution system would ensure uninterrupted oxygen supply to the patient. The terminal outlets shall be of the same design and operational criteria as the self sealing duplex outlets of the distribution system.
- (e) Outlets shall be adequately marked and identified and not interfere with the suction outlet, whenever provided
- (f) Stationary oxygen system shall be accessible from outside of the vehicle and shall be physically isolated from the patient as well as the driver compartment.

Gas Piping

- (a) Gas piping shall not pass through cupboards and compartments, all ducts for gas installations or gas piping shall be vented.
- (b) The use of remote high pressure lines and gauges are not allowed.

Stationary oxygen supply

- (a) The stationary oxygen supply shall comprise a source in accordance with equipment table (under normal temperature and pressure) pressure regulators and terminal units or pressure regulators with flow metering devices. Rescue ambulances should never be operated with lesser number of cylinders as that designated.

Portable oxygen supply

- (a) The portable oxygen supply shall comprise a source in accordance with the equipment table (under normal temperature and pressure) and a pressure regulator with flow metering device.

Pressure regulators and flow metering devices

- (a) The pressure regulators shall be directly connected to the source of supply and shall comply with the following as applicable:
 - (b) b) ISO:10524-1-2006, Pressure regulators for use with medical gases – Part 1: Pressure regulators and pressure regulators with flow-metering devices.
 - (c) ISO:10524-3-2005, Pressure regulators for use with medical gases – Part 3: Pressure regulators integrated with cylinder valves. d) Flow metering devices for connection to terminal units and for connection to flow-rate control units shall be of dial type without any floats and shall conform to ISO:15002

Terminal units

- (a) Terminal units shall comply with the requirements of ISO:7396.
- (b) The components of terminal unit should be cleaned as defined in "Compatibility of Medical Equipment with Oxygen" as per ISO/TC121/SC6 and ISO:15001 2003.
- (c) The terminal outlet should have an hexagonal geometrical profile to permit only geometrically matching adapters.
- (d) The process of inserting the probe into the terminal unit of the distribution system as well as pressure regulators shall be:
 - (i) an axial force not exceeding 100N and/or
 - (ii) a torque not exceeding 1 N-m
- (e) The process of releasing the probe from the terminal outlet should be:
 - (i) applying an axial force having torque not more than 1 N-m and not less than 0.1 N-m.
 - (ii) applying a push or pull force of not more than 110 N and not less than 20 N.
- (f) When all locking provisions have been released, disconnection of the probe from the terminal unit shall require a force of not more than 100 N
- (g) Danger to personnel can occur as a result of the rapid expulsion of probes from terminal units. The design should prevent this from occurring.
- (h) The terminal outlets should be colour coded as per ISO:32-1977 colour coding.

Pneumatic power supply

Pneumatic power supply

- a) If the road rescue ambulance is equipped with terminal units, the range of operating pressure shall be
 - i) for compressed medical gases 3.5 ± 0.5 Bar
 - ii) for vacuum ≤ 0.4 Bar absolute pressure and the maximum allowable pressure change between the source of supply and the terminal units shall be
 - for compressed medical gases 10 % at a flow of 40 l/min;

- for vacuum 20 % at a flow of 25 l/min.

Additional outlet connectors

- (a) For road rescue ambulances complying with Pneumatic power supply, one additional outlet connector (i.e. a terminal unit or a gas specific connection point) complying with the primary outlet shall be fitted in addition to the outlet connectors necessary for the devices intended to be normally used.

Test Pressure

- (a) The gas piping shall withstand a pressure of 8 Bar i.e. twice the maximum operating pressure of 4 Bar.
- (b) Note: This pressure is also the maximum pressure supplied by pressure regulators in single fault condition.

Pin-Index Cylinder Valves

- (a) Pin-index outlet connections of cylinder valves shall comply with IS:3224.

Flexible Hoses

- (a) Flexible hoses for connecting medical devices to outlet connectors (i.e. terminal units or a gas-specific connection points) shall comply with ISO:5359-2008. If flexible hoses are used between the pressure regulators and the terminal units, the requirements of ISO:11197 apply.

Alarms

- (a) The alarm level would be as per IEC:60601-1-8-2006.

Marking and Instructions

- (a) Marking and instructions for use shall comply with Annexure 1 of AIS:125. Operating and maintenance instructions, service records and any other appropriate regulations shall accompany the product.
- (b) Standardized symbols should be used or it should be written in English or any other local language of the area where the equipment is to be used. Usage of any other local languages are not mandatory but is only advised.

Maintenance

The manufacturer shall supply instructions for carrying out preventive maintenance.

Mechanical Strength - Test Methods for Medical Devices for use in Road Rescue Ambulances

Vibration and bump test - The medical devices shall be submitted to the following tests:

- Vibration (sinusoidal) according to IEC:60068-2-6, Test Fc
- Frequency range: 10 Hz to 150 Hz
- Amplitude/acceleration: $\pm 0,15$ mm/2 g
- Sweep rate: 1 octave/minute
- Number of sweep cycles: 4 in each axis
- Random vibration broadband - reproducibility medium according to IEC:60068-2-64, Test Fh
- Acceleration Spectral Density 10 Hz to 20 Hz: $0,05$ g²/Hz
- Acceleration Spectral Density 20 Hz to 150 Hz: $0,05$ g²/Hz

-3 dB/octave

- Total RMS acceleration 1,6 grms
- Duration/axis/mounting: 30 min
- Bump according to IEC:60068-2-27, Test Ea
- Peak acceleration: 15 g
- Acceleration Spectral Density
- Pulse duration: 6 ms
- Number of bumps: 1000 192
- Direction: vertical, with the medical device in its normal operating position(s) IRC:SP:84-2019 193
- free fall - The medical device shall, while functioning, be submitted to the following test:
- Free fall according to IEC:60068-2-31, Test Ec

- Height of fall: 0,75 m
- Number of falls: One on each of the six sides/surfaces of the device

2.6 Recognition and visibility of rescue ambulances-

The Rescue Ambulance Conspicuity Code is split into six Sections.

- (i) Colour
- (ii) Conspicuity Improving Items (C2I)
- (iii) Emblems
- (iv) Warning Lights
- (v) Sirens
- (vi) Recognition of personnel

The Section "colour" describes the vehicles basic colour. The Section "Conspicuity Improving Items" or "C2I" includes all Symbols, Marking and Striping defined as such by this standard. The Section "Emblems" refers to every item that doesn't fall under the definition of C2I which can be private company signs or corporate identities. The Section "Warning Lights" describes colour, position, alignment, luminosity, photometric brightness, flash patterns and electrical current consumption of all used warning lights. The Section "Sirens" determines the volumes, frequencies and electrical current consumption of all used sirens and speakers.

(i) Colour

- The basic colour of the complete exterior should be brilliant blue as per Annexure-I attached, front, rear and side bumpers included. The colour should be weather resistant and withstand daily cleaning and washing

(ii) Conspicuity improving items

- This definition includes all marking and symbols as shown in the figs. 3 and 4 below. All C2I-markings should be in brilliant red, RAL- Code 3024 and in retro reflective quality. "AMBULANCE" markings, the Star of Life and the emergency number symbol. All "AMBULANCE" markings must follow a 7:1 ratio, length to height.
- front: No less than 50 percent of the front side of the vehicle should be brilliant Blue in contrast to no less of 10 percent brilliant red. The word "AMBULANCE" on brilliant blue background, minimum of 65 percent of the hood width, shall be in mirror image (reverse reading) for mirror identification by drivers ahead.
- Side: The side of the vehicle should be equipped with a two lined red on the white ground colour as shown in fig. 4. The vehicle side should be brilliant blue followed by an "AMBULANCE" marking on the same height. "Star of Life" symbol, with a size of 40cm x 40cm, and the emergency number logo, with a size of 40cm x 75cm. The vertical centre from both of them should match the vertical centre of the side windows of the driver cabin. The words "Basic Life Support" shall be marked respectively just above the word ambulance in size no less than 50% of the size of the word "AMBULANCE"

(iii) Emblems

- NHA emblem should be placed in allowed instead of "XXX" in a non-reflecting manner and the size can't be bigger than 60 percent of the "AMBULANCE" markings. Ambulance Calling Number 1033 must be displayed prominently on the side and back of the Road rescue ambulanc

(iv) Warning Light

- All warning lights have to be mounted rectangular to the horizontal ground. They must provide 100 percent of their intensity in a vertical angle of ± 4 degrees and 50 percent in a vertical angle of ± 8 degrees. The minimum intensity is for blue

and red lights at 100cd at daylight and 200cd in the night. The horizontal minimum angle should be at least 45 degrees. All lights must flash between 2Hz and 4Hz and should be mounted as on the graphic below

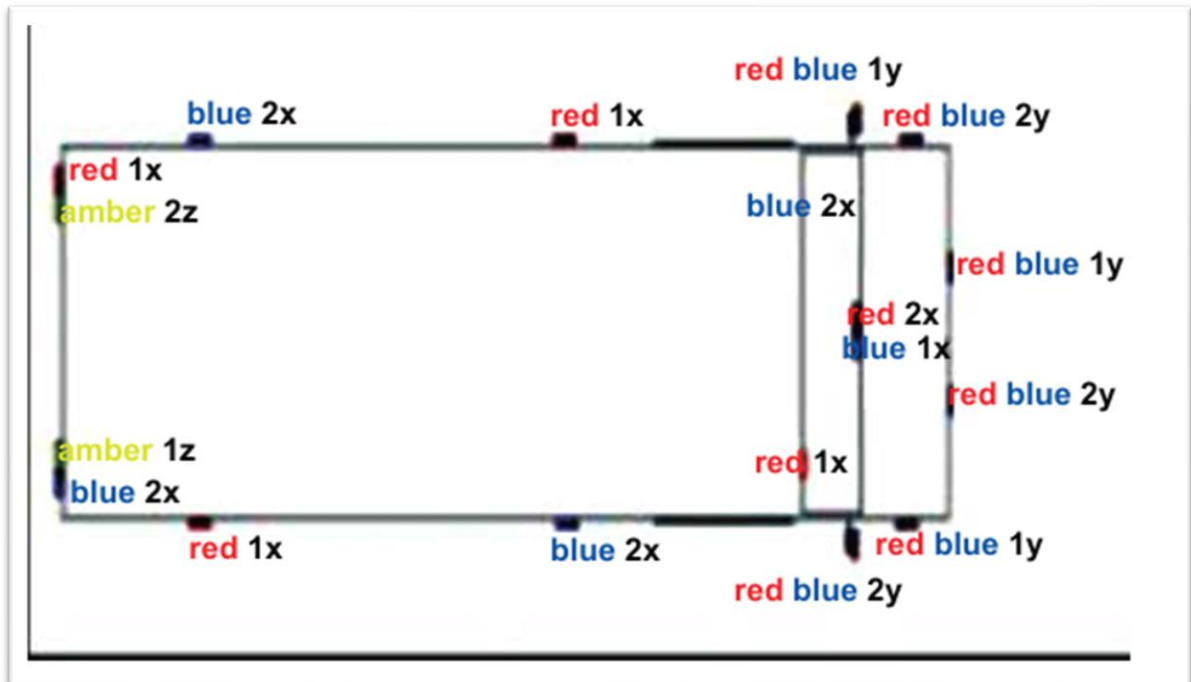

flash pattern

- Indicates light flashing the same time
- Indicates light flashing
- 180 degree out of phase with 1
- 'x' indicates 'ON' lights in primary and secondary mode
- 'y' indicates 'ON' light only in primary mode
- 'z' indicates 'ON' light only in secondary mode

Lights marked with "red blue" must show red and blue in one piece one at a time. In daytime they must flash red in nighttime they must flash blue. Two lights have to be mounted in the lower middle windshield only flashing to the outside of the car. All lights should be flashing as shown in the graphic above. To switch from Primary into Secondary Mode there has to be one switch that allows only one mode.

(v) Sirens

- All siren loudspeakers have to be mounted on the front of the vehicle. Hidden installation is allowed. The main sound direction must be in driving direction. Permitted are wail and yelp signals that cycle between 10–18 respectively 150–250 per minute at an sound pressure level of 110dB(A) to 120dB(A). The sirens should be tested in accordance with IS:1884 (though not covered in the standard). The frequency range must be at least one octave and should be between 500Hz and 2.000Hz. An additional electronic air horn can be used. Further there should be a public address system that can be worked at all times ergonomically from the driver's seat. The siren switch can only be used if the warning lights are on.

(vi) Recognition of personnel

Safety garments for rescue ambulance personnel should conform to at least ISO:14116-2008.

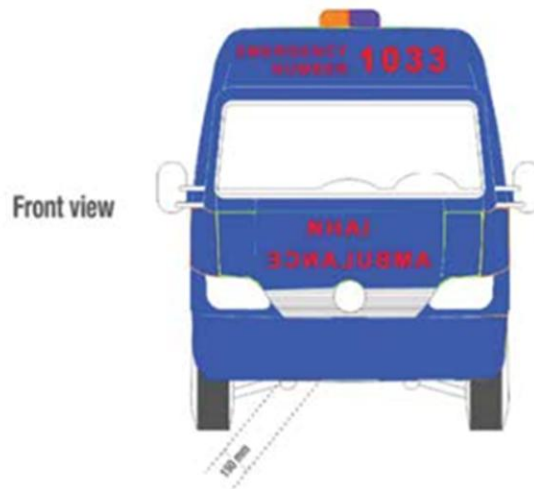

Fig. 3 Rescue Ambulance – Front View

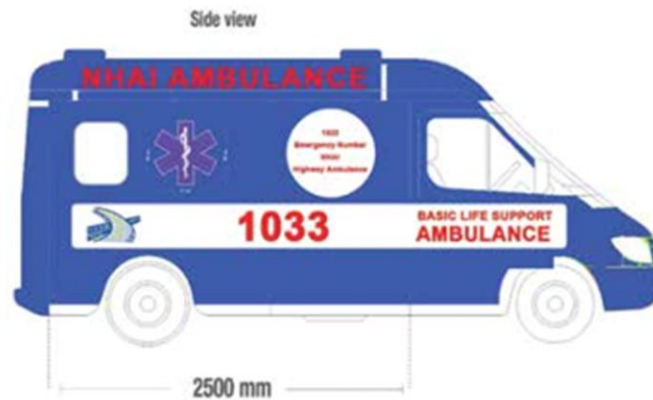

Fig. 4 Rescue Ambulance Side View

Brilliant Blue Colour Code : C: 87%, M: 74%, Y: 0%, K: 0%

3. Rescue Ambulance manpower

Ambulance Paramedics: The Service Provider shall provide 4 (four) paramedics with each ambulance (including relievers)

1 Trained EMT staff with the following qualifications/ experience

- Basic qualification of EMT – Diploma in E.M.T. 11
- B.Sc. (PCB) with certification in BLS/ ALS/ ACLS/ ITLS (or) B.Sc Nursing/ GNM/ ANM (or) B.Pharm/ D. Pharma or any other equivalent paramedical course from recognized university/institution of IMC/INC.
- Minimum 2 years of relevant experience in first-aid and life saving emergency skills including spinal immobilization, bleeding control, oxygen therapy, defibrillation and medicine administration.
- At least one training (minimum one month) in tertiary care institution or at a recognized institute with experience in handling life-saving equipment.
- Basic training in extrication.

Ambulance Drivers–The Service Provider shall provide 4 (four) drivers for each ambulance (including relievers), who shall be good, reliable, licensed, and experienced drivers, capable of operating the Ambulance Vehicles and providing rescue services and qualified in compliance with the requirements

Ambulance Driver Qualifications

- (a) A high school diploma or equivalent is required.
- (b) Certifications relevant to ambulance operation, including those issued by recognized vocational schools or apprenticeship programs offering both classroom and practical training, are desirable.
- (c) Certifications may include a Commercial Driver’s License (CDL) for ambulance operation and/or certified training from accrediting bodies such as an EVOC certificate, which demonstrates skills in road safety, GPS navigation, and legal requirements for emergency drivers.
- (d) Drivers should be able to read, write, and maintain logbooks.
- (e) Ambulance operators should have good mechanical aptitude, precise communication skills, strong spatial awareness, and experience in similar roles. Good physical strength and stamina are required.

Ambulance Driver Responsibilities

- (a) Should have certification in cardiopulmonary resuscitation (CPR) or basic life support (BLS).
- (b) Perform daily maintenance checks and troubleshoot operational issues.
- (c) Understand and adhere to workplace safety policies and regulations
- (d) Communicate effectively with the construction team to coordinate operations.
- (e) Study and understand weight limits, communication signals, and emergency procedures.
- (f) Maintain a clean and safe work environment at all times.
- (g) Employ medical equipment to help load and unload patients into and out of the ambulance.
- (h) Drive to pickup locations and medical facilities quickly and safely.
- (i) Stock the ambulance with the necessary supplies before each shift.
- (j) Assist paramedics during crisis calls.
- (k) Inspect the vehicle before each shift to ensure it’s safe to operate.
- (l) Clean the ambulance’s interior regularly and replace any soiled fabrics or supplies.
- (m) Report any mechanical issues.
- (n) Help carry patients into the medical facility for treatment.
- (o) Use mapping technology to determine the most efficient route between locations.

4. EQUIPMENT & MEDICINE FOR AMBULANCE

(i) List of Equipment

S. No.	Equipment	Quantity
1	Main automatic loading stretcher (length 1900 mm - 1970mm, width 530 mm to 570 mm with loading capacity of 150 kg) conforming to EN 1865 standard	2
2	Scoop stretcher (lightweight aluminum stretcher, length 1600 mm - 2000 mm, width - minimum 42 cms, loading capacity - minimum 150 kgs) conforming to EN 1865 standard	2
3	Vacuum mattress (length 1900 mm - 1970 mm, width 530 mm to 570 mm with loading capacity of minimum 150 kg) conforming to EN 1865 standard	2
4	Long spinal board with head immobilizer & securing straps, waterproof, EN 1865 compliant Long spinal board with head immobilizer & securing straps and	2

S. No.	Equipment	Quantity
	plastic material at high strength, should be waterproof & conforming to EN 1865 standard	
5	Set of fractures/ splints made of mouldable metal or alloy (aluminum) – sizes for both children & adults and for hand & wrist, half arm, full arm, foot and ankle, half leg, full leg (all splints should be washable and reusable)	2 each
6	Cervical collar for both kids & adults (should have pre-molded chin support, locking dials and rear ventilation panel and an enlarged trachea opening, should have high density polyethylene and foam padding, should be X-ray lucent and easy to clean and dis-infect)	4 each
7	KED extraction device	1
8	Stationary oxygen – Minimum 2 Nos. of 10 L water capacity cylinders at maximum 150 kgf/ cm ² filling pressure manufactured as per IS:7285 & certified by chief controller of explosives, Nagpur along with 3/8 bull nose valve as per IS:3224	2
9	Portable oxygen – Minimum 1 Nos. of 10 L water capacity cylinders at maximum 150 kgf/ cm ² filling pressure manufactured as per IS:7285 & certified by chief controller of explosives, Nagpur along with 3/8 bull nose valve as per IS:3224	2
10	Manual resuscitator with oxygen inlet and mask	2
11	Airways (nasopharyngeal airways of size 6.5 mm, 7.5 mm, 7 mm, 8.5 mm & 8 mm & oropharyngeal of size 0, 1, 2, 3 & 4)	2 each
12	Electric portable suction aspirator with air flow of at least 30 L/ min and vacuum level of at least 600 mm Hg (ISO:10079-1-1999)	2
13	Manual portable suction aspirator (IS:4533-1995)	3
14	Suction catheter (12 & 16)	2 each
15	Laryngeal mask airway (kids & adults)	2 each
16	Infusion solutions (litre)	4
17	Equipment for injections & infusions (IV sets)	2
18	Infusion mounting	2
19	Tourniquet (multiple sizes, IS:7971-1987)	2
20	Automatic External Defibrillator with ability to deliver shock up to 200 joules through biphasic technology; should also consist of an audio alarm	1
21	Nebulizer conforming to IS:9462-1980	2
22	Manual BP monitor (cuff size 10–66 cm)	2
23	Portable automatic BP, heart rate & saturation monitor	2
24	Oximeter of ISO:9919 standards	2
25	Stethoscope conforming to IS:3391-1965	2
26	Thermometer (min: 28 degrees to 42 degrees Celsius)	2
27	Device for blood sugar determination	2
28	Diagnostic light	2
29	Blanket	2
30	Non-woven stretcher sheet	2
31	Kidney bowl	2
32	Vomiting bag	2
33	Non-glass urine bottle	2
34	Waste bag	2
35	Bed pan	2

S. No.	Equipment	Quantity
36	Sharps container	2
37	Sterile surgical gloves (pairs)	5
38	Non-sterile gloves for single use	100
39	Basic protective clothing with high-visibility reflective jacket	3
40	Safety / debris gloves	3
41	Safety shoes	3
42	Safety helmet	3
43	Personal protection equipment against infection including disinfectants	3
44	Fire extinguishers (minimum 2 kgs) complying with IS:13849 or IS:2171)	2
45	Hammer	1
46	Shovel	1
47	Hydraulic cutter / spreader	1
48	Warning triangle lights	4
49	Spotlight	1
50	Public addressal system	1
51	Two way radio transceiver or better technology for mobile communication with highway surveillance team, tow away crane & control room	1
52	Internal phone within patient compartment for communication with driver	1
53	Automated vehicle tracking system with GPS technology for continuous tracking of vehicle location	1

(ii) List of medicines & dressing material to be carried in rescue ambulance at all times:

S. No.	Medicines & Dressing Material	Quantity
1	Band-Aids	20
2	Betadine Solution 500ml (bottle)	1
3	Cotton roll 500gm	1
4	Crape bandage 15 cm × 4 mtr	2
5	Crape bandage 7 cm × 4 mtr	2
6	Dressing pad 10 cm × 10 cm (pre-sterilized)	10
7	Dressing pad 10 cm × 20 cm (pre-sterilized)	10
8	Elasto plast (dyna plaster) 10 cm	2
9	Gauge cloth 80 cm × 18 mtr	1
10	Gauge rolls 4"	1
11	Gauge rolls 6"	1
12	Plain bandage of various sizes	3
13	Hydrogen Peroxide 400ml (bottle)	1
14	Micropore tape 2", 4"	2
15	Surgical Spirit Bottle 500ml (bottle)	1
16	Glucose 100gm	2
17	IV Fluid Dextrose 25% (bottle)	5
18	IV Fluid Normal Saline (bottle)	10

S. No.	Medicines & Dressing Material	Quantity
19	IV Fluid Ringer (RL) (bottle)	10
20	IV Fluid 5% GNS (bottle)	5
21	Inj adrenaline 1ml	5
22	Asthalin-nebulizing solution	5
23	Inj atropine 1ml	20
24	Inj avil 2ml	5
25	Budesonide-nebulizing solution	5
26	Inj distilled water 5ml	5
27	Inj diazepam 2ml	5
28	Inj hydrocortisone 100 mg	5
29	Inj lasix 2ml	5
30	Inj paracetamol 2ml	5
31	Inj rantidine 2ml	5
32	Inj tramadol 2ml	5
33	Inj tranexaminic acid	4
34	Inj neostigmine	4
35	Inj haemaccel	2
36	Inj mannitol	5
37	Inj sodabicarb 7.5%	5
38	Inj metaclopramide	5
39	Inj phenytoin	5
40	Inj hyosymine bromide or dicyclomine hydrochloride	5
41	Inj methargin	5
42	ORS 4.20gm	10
43	Syp Antacid Anaesthetic Gel (bottle)	1
44	Syp Paracetamol 60ml (bottle)	1
45	Tab Activated Charcoal (strip)	1
46	Tab Clopidogrel (strip)	1
47	Tab Disprin/Aspirin (strip)	1
48	Tab Paracetamol (strip)	1
49	Tab Isosorbite Dinitrate 5mg sublingual (strip)	1
50	Xylocaine (wocaine gel) 2% 30gm jelly (tube)	1

5. TERMS OF PAYMENT

- 5.1 The Service Provider shall maintain and update logbooks indicating trip details, kilometers run, working hours, breakdowns, and maintenance days, duly signed by the concerned Client's personnel who are using the Vehicle/Client's representative.
- 5.2 The Service Provider shall maintain and update an accident register detailing each accident/incident, including victim(s), date, time, location, tasks performed, first aid given, medical

treatment provided, injury and/or fatality, and any other relevant details.

- 5.3 The logbook shall also record the quantity, rate and date of each fuel refill.
- 5.4 The logbook and accident register shall be submitted to the Client's representative as and when required.
- 5.5 The Service Provider shall submit monthly invoices, duly approved by the Project Manager of the Project along with the logbook and VTS Report/GPS report for certification by the Client on or before the 5th (fifth) day of each month for the Services rendered in the previous month.
- 5.6 At the time of submission of the bill, the fuel Consumption sheet shall be submitted along with the invoice.
- 5.7 If the Service Provider is an MSME vendor, it shall be clearly mentioned on the invoice that they are an MSME vendor. A copy of the valid Udyam Certificate shall be attached with each payment request.
- 5.8 The Client shall make payments within 45 (forty-five) days from receipt of an undisputed invoice with all necessary supporting particulars from the Service Provider.
- 5.9 All payments shall be subject to applicable tax deductions. Payments will be released net of GST, which will be paid upon proof of GST payment.
- 5.10 All payments made to the Service Provider under this Contract shall be made in INR, as per invoices which are approved and duly certified by the Client.
- 5.11 The rate/ contract value includes the lubricants, periodic and regular maintenance costs, overheads, profits and any other incidental costs relating to the Incident Management Vehicles. All wear and tear costs, along with related expenses (maintenance, oil topping, etc.) shall be borne by the Service Provider.
- 5.12 The rate/ contract value also includes drivers' & Paramedic wages, overtime charges (if any), accommodation, food, mobile phone expenses, insurance cost, depreciation, and any incidental costs.
- 5.13 The services provided by the Service Provider are exempt under GST. If any taxes are to be levied under the Applicable Law, the same shall be charged over and above the agreed amount at actuals. GST amounts in invoices shall be due and payable only upon receipt of proof of GST payment/ verification of the same on the GST portal.
- 5.14 The Client shall be entitled, at any time, to request a detailed bifurcation of the monthly fees charged, including a breakdown of costs for drivers and paramedics
- 5.15 If any taxes are to be levied under the Applicable Law, the same shall be charged over and above the agreed amount at actuals. GST amounts in invoices shall be due and payable only upon receipt of proof of GST payment/ verification of the same on the GST portal.
- 5.16 The Client shall be entitled, at any time, to request a detailed bifurcation of the monthly fees charged, including a breakdown of costs for drivers/operators.
- 5.17 Escalation is not applicable to Ambulance services under this contract.

6. HR Compliance

6.1 HR non-compliance with HR requirements, an amount equivalent to 9% of the value of work executed in the current bill (excluding GST) shall be withheld from the invoice, applicable from the second bill onwards, subject to a maximum cap of 5% of the total Contract Value.

However, no HR-related withholding shall be applicable to the current bill, if HR compliance has been duly submitted and accepted in the last paid invoice, the HR compliance amount shall not be withheld in the current bill.

6.2 For Incident Management contracts, HR compliances shall be monitored on a quarterly basis. In case HR non-compliance continues for six consecutive months, the contract shall be liable for termination.

6.3 The Service Provider shall submit the following with respect to the compliances along with the monthly invoice:

Sr.no	Type of compliance	Frequency of compliance and submission	Type of Document
1	Pay sheet	Monthly	Service Provider shall submit a declaration stating that it had complied with minimum wages
2	PF remittance details (ECR) (Challan)	Monthly	Consolidated challan & declaration
3	ESI remittance details (Challan)	Monthly	Consolidated challan & declaration (if applicable)
4	Insurance policy (GPA copy/WC- if ESI not applicable)	One time	Copy of WC policy –only in case of non-ESI area.
5	Insurance policy for public liability	One time	Cover will be by the Client, but responsibility, indemnity and impact with Service Provider.
6	Vehicle insurance	Yearly	Copy of insurance

6.4 The Service Provider shall provide backup documents regarding labour compliance, if any, as and when asked by the Client, within [3 (three)] working days of such request.

7. DEFICIENCY AND PENALTY

7.1 Service provider shall provide a replacement of the Incident Management Vehicle of similar facility whenever the agreed Ambulance is not available due to any reason whatsoever. An amount of INR 5,000/- (Indian Rupees Ten Thousand Only) per day would be deducted for providing a replacement Incident Management Vehicle of lesser make or capacity, for more than 1 (one) day in any month for each Incident Management Vehicle.

7.2 **Fuel Charges Variance Clause-** if the ambulance runs less than the fixed KMs then the deduction will be calculated on the standard of the Rs.12/Km, and in case ambulance runs more than the fixed KMs then the extra amount will be paid to the on the standard of the Rs.12/Km.

7.3 **Shortfall in Deployment of Incident Management Vehicle Driver** - In case of non-manning of the

Incident Management Vehicle, the Service Provider shall deploy the manpower as specified in the Contract Agreement. For any missed shift, a penalty of INR 1,000 per shift shall be levied and deducted from the invoice until the manpower shortfall is fully rectified.

7.4 **Not Wearing Uniforms-** In case any driver/Paramedic is found not wearing the prescribed uniform and/or not carrying a valid ID card during duty, a penalty of INR 100 per person per shift shall be levied and deducted from the invoice.

7.5 **Carrying ID cards-** The driver and Paramedic shall mandatorily carry identity card during duty hours.

7.6 **Failure to Deploy Required Equipment -**

- All consumables shall be replenished before the next use. A minimum inventory level, as specified in the Contract, shall be maintained at all times. The Client shall provide suitable space at each toll plaza along the Project stretch for parking and stationing of the Vehicles.
- Faulty equipment shall be repaired or replaced within 7 (seven) working days.
- All medicines and consumables shall be replenished immediately after use and before the next deployment of the Ambulance Vehicle. A minimum inventory level, as prescribed under the Contract, shall be maintained at all times. The medicines stocked in each Ambulance Vehicle shall be sufficient to provide treatment to at least five (5) persons simultaneously. The Client shall provide suitable and adequate space at every toll plaza along the Project stretch for the parking and stationing of the Ambulance Vehicle.
- **Non-availability of any equipment** -In case of non-availability or non-working condition of any equipment, the Vendor shall be officially notified. The Vendor shall repair or replace the concerned equipment within 7 (seven) days from the date of such intimation. If the equipment is not repaired or replaced even after the stipulated 7 days, a penalty of INR 400 (Rupees Four Hundred only) per day shall be levied until the equipment is repaired or replaced.
- **Non-availability of consumable items, including medicines and dressing materials-** The Contractor shall ensure that sufficient medicines and dressing materials are always available in the ambulance. Refilled of all consumable items, including medicines and dressing materials, shall be carried out fortnightly each month. In case of non-maintaining of shortage of medicines and dressing materials on fortnightly basis, a penalty of INR 100 per day shall be levied and deducted from the Contractor's invoice until such items are fully replenished.

7.7 **Misconduct of staff-**

In the event of any misconduct by the Service Provider's staff:

- First instance: A written warning shall be issued.
- Second instance: The concerned staff member shall be suspended from duty for a period of seven (7) days.
- Third instance: The Client reserves the right to terminate the Contract as per the terms and conditions of the Agreement.

Any deviation, variation, omission, or failure to comply with the Scope of Work, without prior written approval of the Authority, shall be treated as a material breach of contract and shall render the Contract liable for termination, in addition to imposition of penalties and other remedies available under the Contract and applicable law



सत्यमेव जयते

भारतीय राष्ट्रीय राजमार्ग प्राधिकरण

(सड़क परिवहन और राजमार्ग मंत्रालय, भारत सरकार)

National Highways Authority of India

(Ministry of Road Transport and Highways, Government of India)

जी-5 एवं 6, सेक्टर-10, द्वारका, नई दिल्ली - 110 075 • G-5 & 6, Sector-10, Dwarka, New Delhi-110075

दूरभाष/Phone : 91-11-25074100 / 25074200



NHAI/ Policy Guidelines/ Road Safety/ 2024

Policy Circular No.12.36/2024 dated 12th December, 2024

{Decision taken on E-Office File No. RMDIV-21/1/2024-RMD Division (Comp. No. 266572)}

Sub: Amendment to NHAI/ Policy Guidelines/ Strengthening the Incident Management Services/ 2019 Policy Circular No. 12.19 dated the 20th March 2018- reg.

Route Patrolling Operations play a critical role in maintaining Safety and ensuring smooth traffic flow on Highways/Designated Routes. Route Patrol Vehicles (RPVs) are deployed to conduct routine inspections of Highway stretch, monitor and respond to incidents / near-miss incidents and provide immediate assistance to road users in emergency situations. Equipped with trained Manpower, advanced Communication and Safety Tools, these Vehicles are essential for upholding regulatory standards, minimizing traffic disruptions, improving Road Safety and enhancing overall Road User experience along our Highways.

2. The detailed specifications for the Patrol Vehicle have been outlined under Annexure-1 of NHAI/Policy Guidelines/ Strengthening the Incident Management services/2018 Policy Circular No.12.19, dated the 20th March 2018. With the recent Technological Advances and experience gained, it has been decided to update the above-mentioned specifications. Accordingly, the specifications of the Patrol Vehicles deputed on the National Highways stands amended and replaced by the specifications stipulated in **Appendix-I** of this Circular. In consideration of the same:

- i. New Route Patrol Vehicles (RPVs) hired/procured henceforth shall be in accordance with these specifications.
- ii. The existing RPVs undertaking route patrolling tasks across various Highways of NHAI shall be upgraded as per these specifications within a period of six months from the date of issuance of this Circular at no additional cost .
- iii. However, the cost of CAMERA with AI Software, only shall be borne by NHAI.
- iv. Provision for installation of Dashboard Cameras is to be provided in the existing RPV units. The data/ video footage including Road distresses using the Dashboard Camera shall be collected in the presence of concerned Authority Engineer (AE) and a Representative of Project Implementation Units (PIU), NHAI. This Road distresses data must be uploaded by the AE on NHAI One application. Further, this data from the Dashboard Cameras shall be provided by the PIUs to the NHAI HQ on monthly basis. Detailed SOP in this regard shall be issued separately by NHAI HQ.
- v. Approval of these modifications/alterations with respect to CMVR Provisions/RTO Regulations shall be taken at RO Level with concerned State Governments.

Contd...2/-

3. This Policy also outlines the functions of Route Patrolling along our Highways, Details on Components of Route Patrolling including Route Patrolling Vehicle (RPV), Inventory in RPV and Manpower requirements in RPV with their broad Responsibilities are stipulated at **Appendix-II** and **Appendix-III** of this Circular respectively.
4. This issues with the approval of Competent Authority.



(CS. Sanjay Kumar Patel)
General Manager (Coord.)

To:

All Officers of NHAI HQ/ ROs/ PIUs/ CMUs/ Site Offices

Copy to:

1. Hindi Division for translation in Hindi.
2. Library for hosting the circular on library site.
3. Web Admin for circulation.

Patrol Vehicle Specifications

Every Route Patrol Vehicle (RPV) should adhere to the minimum specifications as described below:

General Vehicle

Sr. No.	Type	Description
1	Vehicle type	<ul style="list-style-type: none">• RPV should be a large size Sport Utility Vehicle (SUV) or Multi Utility Vehicle (MUV) with a seating capacity of minimum 4 people including the driver.• RPV should be able to accelerate from 0km/ h to 80 km/ h within 20s when tested in accordance with IS: 11851-1986.• The Route Patrol Vehicle (RPV) should be capable of maintaining stable and controlled movement in case an emergency situation demands high speed movement.• The RPV should be a new vehicle and should not have covered more than 2000 km (mileage) at the time of procurement. Once a vehicle has either exceeded 3,00,000 kilometers or has been in operation for three years, whichever occurs first, it shall be replaced with new RPV.• Rear or trunk of RPV shall be of closed ceiling with cabinet shelves and dedicated space of each equipment and inventory. The shelves shall be so designed that accessing any equipment shall be quick, easy and with least dependency on any other equipment. Cabinet design with dimensions shall be as shown in Figure 2. It may be noted that, closed cabinet storage-based design has been prepared to accommodate all proposed inventory in RPV and to facilitate easy accessibility during incident handling. It may further be noted that, the dimensions mentioned in Figure 2 are minimum requirements to accommodate the inventory. Improvisation in the shared design / layout arrangement shall not be conducted, unless otherwise approved by the concerning authority based on project specific / region specific requirements.
2	External Appearance	<p>Emblems, Logo, Marking & Colour Scheme:</p> <p>To maintain uniformity across the country, external appearance of RPV shall be as shown in figure 1.</p> <ul style="list-style-type: none">• Complete body exterior should be painted with PU base 2K paint, white in colour with red stripe pattern as shown in the image below. The placement, font style, size and overall dimensions of Logo, authority name and emergency number shall be followed as shown in figure 1 and as described below.○ RPV should have "RAJMARG SAATHI", "NHAI", "SPV" Logo, texts "NHAI" & "HIGHWAY PATROL UNIT" written on the vehicle as shown in figure 1.

Sr. No.	Type	Description
		<ul style="list-style-type: none"> ○ On the storage cabinet: Diameter of logos (NHAI and RAJMARG SAATHI) shall be 550mm and font height of letter "HIGHWAY PATROL UNIT" shall be 60mm. ○ On the Passenger Doors: Diameter of logos (NHAI and SPV) shall be 500mm. ○ On bonnet: Diameter of "NHAI" logo shall be 550mm. ○ Font Height of "NHAI" written on the trunk body shall be 200mm height. <ul style="list-style-type: none"> ○ Font style English: "Arial Black" & Font style Hindi: "Krutidev 040". ○ Font colour shall be followed as per the colour scheme shown in the figure 1. ● Rear of the vehicle shall be provided with fluorescent yellow and red stripe pattern with reflective paint as shown in the image. The stripes must slope downward and away from the centre line of the vehicle at an angle of 45°. Each stripe must be 6-inches wide and in an alternating pattern of red and yellow. Additionally, retroreflective striping inside vehicle doors is essential to maintain conspicuity and alerting to the passing drivers when the doors are opened.
3	Lighting and Illumination	<p>The RPV shall be equipped with fog lamps, warning lights, a roof-mounted rear bar light and a front LED bar light with siren, in addition to standard vehicle indicators, headlamps, and tail lamps.</p> <p>Warning Lights: The warning light system shall be installed externally as per the specified arrangement, colour, and size detailed in the image provided. These lights shall alternate between red and blue colours, flashing at a rate of 60 to 90 flashes per minute. To help other drivers recognize the RPV's operational status, distinct emergency lighting patterns shall be used to differentiate between a moving and stationary vehicle. This can be achieved through various strobe patterns, light configurations, and colour sequencing.</p> <p>Roof-Mounted Rear Bar Light: The roof-mounted rear bar light shall be programmed to flash at 60 to 90 flashes per minute in alternating red and blue colours.</p> <p>All light assemblies must be made of weatherproof materials to prevent electrolysis and corrosion between the light housing and the vehicle body.</p>
4	Siren with Public Address System	<p>A high-quality combination electronic siren with Integrated Public Addressing System of minimum 100W (PMPO) shall be provided. The siren's controls should have full range volume control and should permit the following sounds: Manual, Wail, and Yelp. The siren sweep rate should be 10-18 cycles per minute. The microphone should be of a noise-cancelling type. Siren/Speakers shall not protrude beyond the face of the bumper or bumper guards if provided in there. The control panel for this system should be fixed at a suitable location in the driver compartment.</p>

Sr. No.	Type	Description
5	Cameras for Intelligent Support	<p>A Dashboard camera with GPS with AI video analytics fixed on the front dashboard positioned to capture the view of the highway, and identify road defects like cracks and potholes respectively shall be installed in the RPV.</p> <p>It should possess advanced capabilities beyond mere recording. Dashboard camera to be equipped with AI-powered object detection and classification algorithms to automatically identify and categorize various elements of the road environment, including vehicles, pedestrians, road signs, and infrastructure.</p> <p>Minimum Specifications for Cameras:</p> <ul style="list-style-type: none"> • 2Megapixel, 1920x1080 at 30fps, FOV (D:125, H:105, V:58). • Operating Environment: Temperature: -20 to +70 degrees Celsius, humidity: 10% to 90%, atmospheric pressure: 860mbar to 1080mbar. • Memory Storage: minimum 256GB. • Support: Wifi, 4G (minimum), GPS, 2GB RAM, G-sensor (3axis acceleration sensors). • Camera shall support IR capabilities. <p>This data can then be used to create a comprehensive inventory database of road features, aiding in infrastructure management, route planning, and hazard identification.</p>
6	Route Patrol Personnel	<p>Recognition of personnel</p> <p>All PV Personnel should wear brilliant blue color uniform including brilliant blue color jackets required in winters with reflective stripes, authority name, logo (NHAI & RAJMARG SAATHI logo). Safety garments for PV personnel should conform to at least ISO 14116:2008.</p> <p>Steel-toe Safety Boots to protect against impact and falling objects with slip resistant sole and ankle support shall be used at all times.</p> <p>Uniforms should be clean, well-maintained and free of tears or excessive wear for a professional appearance. Avoid Loose or Dangling Accessories: Minimize wearing any loose items that could catch on equipment or pose a safety risk.</p>

The branding and recognition pattern of RPV described above should resemble with the one shown in the sketches below:



Figure 1: Side and Rear view of the RPV

Handwritten signature

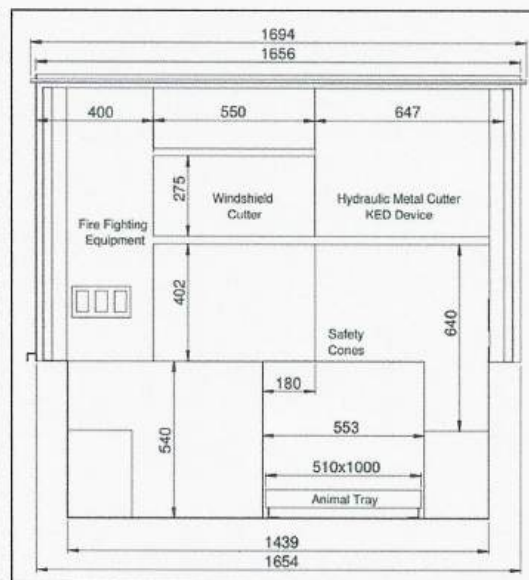
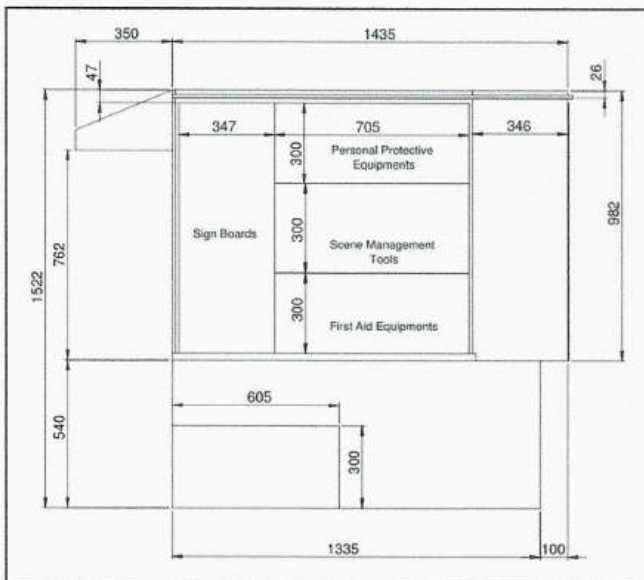
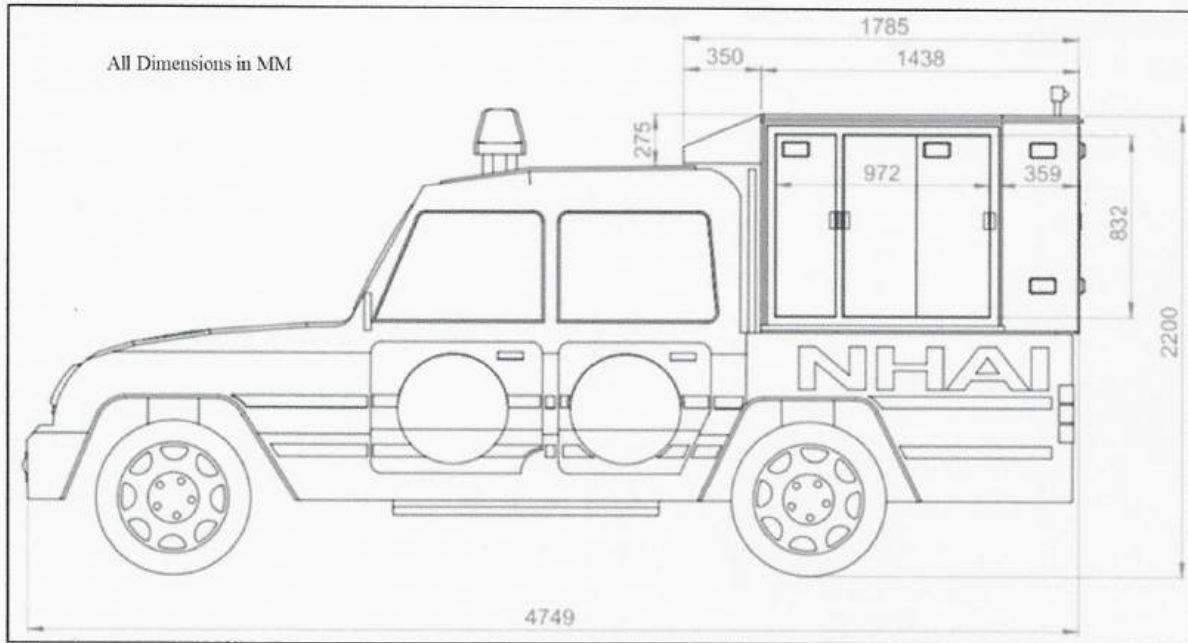

Figure 2: Cabinet-Storage Based Route Patrolling Vehicle Arrangement

Appendix-II

Equipment and Inventory in Route Patrolling Van

Following are the list of equipment and specification of each to be kept in working condition in every RPV:

S. No.	Type	Description
1	Tracking Equipment	Automatic vehicle tracking system with GPS technology for tracking vehicle's current location; GPS Technology shall be in accordance with AIS-140 requirement of Vehicle Tracking System (VTS) of NHAI
2	Communication Equipment	<ul style="list-style-type: none">• 1 Mobile communication device with camera and internet connectivity.• 1 Two- way radio device with antennae or better technology for mobile communication, for communication with on-road control room units. It should have a sufficient range to communicate in the entire section with sufficient battery life (12 hours+). This is mandatory along highways having telephonic blackspot locations.• 1 Siren with Public Address System as mentioned in the vehicle description in the table above.• Dashboard camera with GPS and AI video analytics fixed on the front dashboard.
3	General Surveillance Equipment	<ul style="list-style-type: none">• White color high intensity torch lights with two set of spare batteries (2Nos)• Orange color reflective safety jacket and Gum boots (3 Nos sets, 1 for each attendant)• Helmet with whistle attached on side (3 Nos sets, 1 for each attendant)• Rain suit with reflective strips (3 Nos, 1 for each attendant)• 5L capacity liquid containers for carrying fuel along with a funnel (2 Nos, one for each: petrol and diesel)• Drinking Water container with 5L capacity (1No)• Rope of minimum 20 m length (1Nos) (suitable to tow LMV)• Red color reflective flags made of santoon fabric, dimension of 600x900mm (5Nos)• Baton lights, red and green color, 21inch length and 1.25-inch diameter (2Nos)

S. No.	Type	Description
4	Vehicle Repairing Equipment	<ul style="list-style-type: none"> • Leather gloves (3Nos, 1 for each attendant) • Rubber gloves (3Nos, 1 for each attendant) • 20-ton hydraulic jack, should be able to attain a maximum height of at least 300 mm (1No), shall also be suitable for cars as well as for medium / large trucks • Heavy duty steel towing chain of minimum 1.5 m length (1 Nos) • Portable tyre inflator pump with tyre gauge capable of filling tires up to a pressure of 50 psi; should be able to inflate tires of cars, buses and light trucks (1No), Tyre Sealant (500ml) • Starter leads with multi-meter: For making connections with external power source (1 pair) • Tow bar for towing purposes, 1.3m long (1Nos) • Mechanical toolkit with equipment like hammer, fencing pliers, mallet, ratchet wrench set, screwdriver set, battery brush, etc. • Tow hook in the front as well as rear
5	Extrication & First Aid Equipment	<ul style="list-style-type: none"> • 1 Hydraulic/electric portable hand cutter and spreader combined tool should be able to cut off vehicle parts, metal structure, steel plate. Should have maximum cutting force > 250 KN, spreading force > 25KN with opening distance of Blades > 150 mm • 4 wooden wedges - 4 rectangular wooden blocks of minimum dimensions 150 * 120 * 60 mm for stabilizing light and heavy vehicles • Woollen blankets (2Nos) • First aid kit (1No) <ul style="list-style-type: none"> ○ 24 small sterilised dressings, 12 medium size sterilized dressings, 12 large size sterilized dressings, 12 large size sterilized burn dresses. 12 (15 cm) packets of sterilized cotton, wool. ○ (200 ml) bottle of certimide solution (I) or suitable antiseptic solution, 1 (200ml) bottle of mercurochrome (2%) solution in water, 1(120ml) bottle of sal- volatile having the doses and mode of administration indicated on the label. ○ A pair of scissors. ○ 1 role of adhesive plaster (6 cm into one meter), 2 role of adhesive plaster (2 cm into one meter). ○ Twelve pieces of sterilized eye pads in separate sealed packets. ○ A bottle containing hundred tablets (I each of 325 mg) of aspirin or any other analgesic.

S. No.	Type	Description
		<ul style="list-style-type: none"> ○ Twelve roller bandages 10 cms wide. Twelve roller bandages 5cms wide. ○ 1 tourniquet. ○ a supply of suitable splints, 3 packets of safety pins. ○ Kidney tray. ○ A snake bite lancet. ○ 1 (30ml) bottle containing potassium permanganate crystals. ○ 1 copy of first aid leaflet issued by the Directorate General. ○ 6 triangular bandages. ○ 2 pairs of suitable sterilized latex hand gloves. ○ Burn Gel Packets, Sterile Burn Dressings ○ Sufficient number eye wash bottles filled with distilled water or suitable liquid clearly indicated by a distinctive sign which shall be visible at all times. ○ 4% xylocaine eye drops and boric acid eye drops and soda by carbonate eye drops. ○ CPR Face Shield, Pocket Mask, Disposable Gloves ○ Hand Sanitizer ○ Tweezers, Thermometer (Digital), Instant Cold Packs ○ Pain Relievers (Ibuprofen, Acetaminophen or likes), Antihistamine Tablets (For allergic reactions), Aspirin
6	Scene Management Equipment	<ul style="list-style-type: none"> ● Minimum 20 Reflective cones of 750 mm each, should be orange in colour with retro-reflectors white band and a heavy rubber base with minimum possibility of being displaced by wind/vehicular traffic ● 4 kg dry Powder Fire Extinguisher ISI marked & conforming to BE: 13849-1993 or latest) (2 Nos) ● Hard bristle broom (1Nos) ● Shovel (1 No) ● Signboard with chevron arrows on both side and Mechanism to stand by itself. (6Nos) as shown in Figure-3. (Size - 900mm*900mm) ● 2 numbers of foldable tripods to raise the height of first signboard, depending on traffic characteristics along the highway. ● 6 numbers of flashing light for fixing on each signboard to improve visibility whenever signboard is installed while handling the incident <p>Solar/ battery-based flashing LED light along with clamp / magnetic arrangement for fixing on to signboard (minimum 12 hours backup and minimum visibility distance of 500m). Few images for reference are shown alongside.</p> <div style="text-align: right;">  </div>

Handwritten signature

S. No.	Type	Description
		<ul style="list-style-type: none"> • Red colour Reflective tape of 4-inch width (1role), Caution Tape (1 role) • 3 pairs of safety glasses and masks for protection of safety officers from glass debris/ airborne dust. • 10 kg sealed bucket with lime or cement inside • 5kg Sandbag to handle oil spills on the highway • Animal hook, 1.3m long (1No) • Rock Salt bag of 5kg, with cool box, dead body cover / bag for smaller dead animals of weight up to 50kg

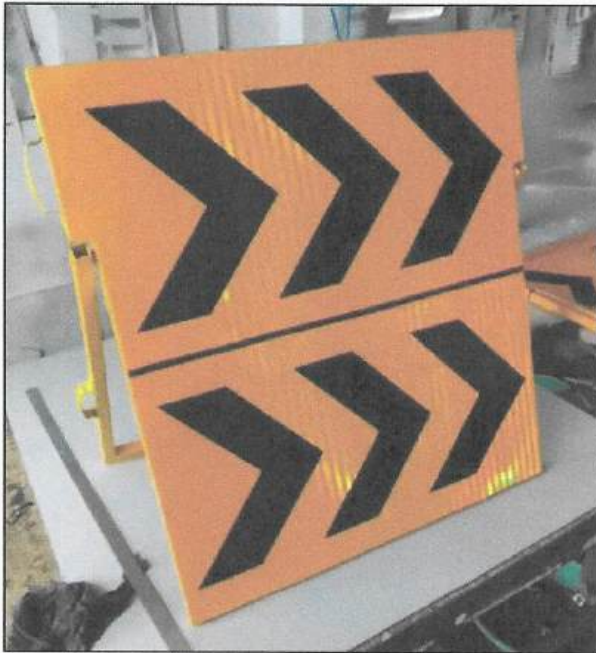

Figure 3: Modular sign board with Front and Back view

[Handwritten signature]

Manpower in Route Patrolling Team along with Broad Responsibilities

Route Patrolling essentially consists of regular surveillance along highways to provide following functions towards Highway Asset Management and Road User Response Services -

1. Monitoring and Surveillance along the Highway

- a. Road Property Management - Identify, Record, Report and Coordinate to Resolve encroachments, hazards and incidental damage to Road Asset caused by vehicles, floods, storms or other random
- b. Identify, Report Issues related to Engineering, Education and Enforcement Implementations along the Highway

2. Incident Management and Roadside Assistance / Emergency Response to Road Users

- a. Identify, Report and Resolve hazards impacting Smooth and Safe Traffic Movement e.g.- vehicle breakdowns, unauthorized parking, hazardous material spill along highway, visibility obstructions, dead animal removals, traffic violations, etc.
- b. Identify, Report and Facilitate Emergency Response to Road Users during Incidents / Accidents including coordination with enforcement, medical agencies and authorities

The manpower and training requirements for the smooth operation of RPVs to perform above functions shall be as stipulated in the table below:

S. No.	Manpower Details	Broad Responsibilities
1	Highway surveillance in- charge	
	<ul style="list-style-type: none"> • 1 Highway surveillance in-charge should be appointed per shift per vehicle • The employee appointed should have a minimum of 2 years of relevant experience in route patrolling and traffic management. • The employee appointed should be able to read/write and maintain logbooks. • Employee appointed should undergo trainings including fields such as <ul style="list-style-type: none"> ○ Vehicle use and maintenance ○ Safety policies 	<ul style="list-style-type: none"> • Patrol the corridor to ensure obstruction free flow as per shift standards. • To report to police and assist injured at accident scene and remove all obstructions from road when the vehicles are cleared. • To provide first aid to injured, contact control room and ambulance service if needed, assist police. • Record and report all incidents to control room (damaged or missing signage, barriers, or guardrails, accidents, debris, any anomalies activities observed on highway) • To ensure safety of traffic with minimal delay at accidents. • To assist motorists on broken down vehicles and to ensure that they do not obstruct free

S. No.	Manpower Details	Broad Responsibilities
	<ul style="list-style-type: none"> ○ Radio and communication procedures ○ Public relations/ customer service ○ Public relations/customer service ○ Traffic Management ○ Vehicle recovery procedures ○ Victim extrication procedures ○ Extinguishing vehicles fires ○ Basic first aid training ○ Work side protection ○ Minor vehicle repairs ● Employee appointed should time to time undergo certified trainings declared by the Authority related to Incident Management within the given stipulated timelines to continue his/her services 	<p>flow. Report in Control Room for arranging tow-away cranes or suitable help for the same.</p> <ul style="list-style-type: none"> ● Maintain relations with all emergency services, and local safety councils. ● To report condition of drainage, ROW plantations, median plantation etc along the Highway. ● Check on encroachment irregularities taking place within ROW and prevent unauthorized entry into the corridor. ● Prevent theft of assets. Identify and report any such thefts of highway assets along highway. ● Attend to urgent maintenance for safety requirements. ● Remove poster, advertisement from sign boards, RE Wall, arrest garbage dumping adjacent or within ROW. ● Conduct awareness campaign at villages, schools adjacent to highway and carry out enforcement drives at identified blackspot locations with the help of local authorities. ● Conducting Dry run and mock drills for the patrolling team. <p>All times, the Route Patrol In-Charge should have with him a list of telephone numbers and address of all concerned stakeholders in providing the road users services.</p>
2	Driver cum helper	
	<ul style="list-style-type: none"> ● 1 driver/ helper should be appointed per shift per vehicle ● Employee appointed should have a valid license to drive a SUV vehicle. ● Employee appointed should be able to read/write & maintain logbooks. 	<ul style="list-style-type: none"> ● Regularly check and maintain the patrol vehicle, ensuring it's in good working condition (fuel levels, engine condition, tire pressure, lights, horn (forward and reverse) wipers etc.). ● Report any vehicle issues or required repairs to supervisors promptly.

S. No.	Manpower Details	Broad Responsibilities
	<ul style="list-style-type: none"> • Basic training of employee should include fields such as <ul style="list-style-type: none"> ○ Vehicle driving along multiple shifts ○ Minor repairing of vehicle ○ Vehicle and equipment use and maintenance ○ Radio and communication ○ Defensive driving ○ Extinguishing vehicles fires ○ Work site protection • Employee appointed should time to time undergo certified trainings declared by the Authority related to Incident Management within the given stipulated timelines to continue his/her services 	<ul style="list-style-type: none"> • Offer basic assistance, such as jump-starting stranded vehicles and assisting with flat tires, fuel etc. • Assist emergency responder and highway surveillance in-charge in route patrol activities.
3	Emergency Responder	
	<p>1 Emergency responder should be appointed per shift per vehicle</p> <p>Basic qualification shall be 12th pass with 2 years' experience in basic first aid and CPR</p> <p>a certified course in Basic First Aid and CPR, such as those offered by organizations certified organizations</p> <p>Basic training of employee should include fields such as</p> <ul style="list-style-type: none"> • Vehicle and equipment use and maintenance • Basic First Aid Training (wound care, bleeding control, burn treatment, fracture and sprain management) & CPR • Basic life support skills Training in techniques like the recovery position, assessing vital signs, and supporting an individual's 	<ul style="list-style-type: none"> • Assist Highway surveillance in-charge and helper to carry out route patrol activities. • Ensure all necessary patrol equipment (e.g., cones, first aid kit, emergency lights) is stocked, functional, and readily accessible in the vehicle. • Respond promptly to accidents or incidents, providing initial assistance and securing the area to prevent further risks, alert oncoming traffic and create a safe zone around the incident. • Perform minor maintenance on highway infrastructure, such as clearing debris, removing obstacles impacting safe traffic movement and needs immediate rectification, or replacing small items like reflectors. • Report emergency repairs, such as damaged barriers, sign board etc and ensure road conditions are safe.

S. No.	Manpower Details	Broad Responsibilities
	<p>breathing. Ability to identify life-threatening situations (such as heart attacks, strokes, or choking) and provide immediate support.</p> <ul style="list-style-type: none"> • Emergency scene management and assisting public to maintain order • Basic personal safety training, protecting themselves from bloodborne pathogens and other hazards during medical assistance (using gloves, masks, etc.) • Victim extrication from a crashed/damaged vehicle • Extinguishing vehicles fires • Employee appointed should time to time undergo certified trainings declared by the Authority related to Incident Management within the given stipulated timelines to continue his/her services 	<ul style="list-style-type: none"> • Document and report daily patrol logs, including any observations, incidents handled, and maintenance activities performed. Take photos or record details as required for official documentation of incidents.

National Highways Infra Trust

 <p>NHIT National Highways Infra Trust</p>	Scope of Works	Doc No.: NEPL/FY25-26/RFP/ Incident Management
---	-----------------------	--



Annexure C3 Bill of Quantity

National Highways Infra Trust

 National Highways Infra Trust	Scope of Works	Doc No.: NEPPL/FY25-26/RFP/ Incident Management
--	-----------------------	---

3.1. Detailed requirements of Ambulance (Including fuel & Driver) at the various project are as follows:

Sr.No.	Project	Chainage From	Chainage To	Total Length (in Km)	No. of Ambulance	To be Awarded Per month km Running	Rent/ Month (Ex. GST) in INR
1	Kachugaon Kaljhar (Patgaon)	30+000	92+671	62.671	2	400	
2	Kachugaon Kaljhar (Dahalpara)	961+500	1013+000	51.500	2	700	
3	Kaljhar Patacharkuchi	1013+000	1040+300	27.300	1	400	
4	Orai Bara (LHS)	1515+713	1578+872	62.903	2	800	
	Orai Bara (RHS)	1515+713	1578+360				
5	Chichra Kharagpur	16+130	72+250	56.120	2	800	
6	Gundugolanu - Chinna Avutapalli Section from Existing Km 1023+496 to 1076+280	1050+680	1076+280	27.20	1	1200	

The detailed Scope of Work is provided in Annexure-C2. Any deviation, variation, omission, or failure to comply with the Scope of Work, without prior written approval of the Authority, shall be treated as a material breach of contract and shall render the Contract liable for termination, in addition to imposition of penalties and other remedies available under the Contract and applicable law.

National Highways Infra Trust

 National Highways Infra Trust	Scope of Works	Doc No.: NEPLL/FY25-26/RFP/ Incident Management
--	-----------------------	---

3.2. Detailed requirement of RPVs and Cranes (including Fuel & Driver/Operator) at the various project are as follows:

A. Deployment Schedule for Route Patrolling Vehicles (RPVs)

S. No.	Project Location / Toll Plaza	Chainage From	Chainage To	Length (Km)	No. of RPVs	Monthly Running (Km)	Rent/ Month (Ex. GST) in INR
1	Kachugaon Kaljhar (Patgaon)	30+000	49+600	19.600	1	4,278	
2	Kachugaon Kaljhar (Patgaon)	49+600	92+671	43.071	1	8,503	
3	Kachugaon Kaljhar (Dahalpara)	961+500	971+200	9.700	1	2,046	
4	Kachugaon Kaljhar (Dahalpara)	971+200	1013+000	41.800	1	8,724	
5	Kaljhar Patacharkuchi	1013+000	1040+300	27.300	1	5,192	
6	Orai Bara	1515+713	1541+100	25.387	1	5,170	
7	Orai Bara	1541+100	1578+872	37.772	1	7,699	
8	Chichra Kharagpur	16+130	43+350	27.220	1	5,650	
9	Chichra Kharagpur	43+350	72+250	28.900	1	5,952	
10	Gundugolanu - Chinna Avutapalli (Kalaparru)	1050+680	1076+280	27.20	1	6396	

B. Deployment Schedule for Farana Cranes (30 MT)

S. No.	Project Location / Toll Plaza	Chainage From	Chainage To	Length (Km)	No. of Cranes	Monthly Running (Hours)	Rent/ Month (Ex. GST) in INR
1	Kachugaon Kaljhar (Patgaon)	30+000	49+600	19.600	1	50	
2	Kachugaon Kaljhar (Patgaon)	49+600	92+671	43.071	1	50	
3	Kachugaon Kaljhar (Dahalpara)	961+500	971+200	9.700	1	50	
4	Kachugaon Kaljhar (Dahalpara)	971+200	1013+000	41.800	1	50	
5	Kaljhar Patacharkuchi	1013+000	1040+300	27.300	1	50	
6	Orai Bara	1515+713	1519+880	4.167	1	70	
7	Orai Bara	1519+880	1578+872	58.992	1	70	
8	Chichra Kharagpur	16+130	43+350	27.220	1	50	
9	Chichra Kharagpur	43+350	72+250	28.900	1	50	
10	Gundugolanu - Chinna Avutapalli (Kalaparru)	1050+680	1076+280	27.20	1	50	

General Scope of Work & Specifications

1. Route Patrolling Vehicles (RPV): The contractor shall provide Route Patrolling Vehicles (RPV) on a monthly hire basis as per the latest IRC: SP 84-2019 (Annexure C) and NHA policy guidelines no. 12.36/2024 dated 12.12.2024 & Annexure C2.

2. Farana Cranes (30 MT): The contractor shall provide Farana Cranes (30 MT capacity) with relevant safety features on a monthly hire basis as per the latest IRC: SP 84-2019 & Annexure C2.

3. Statutory & HR Compliances (Applicable to all): All deployments must comply with the Central/State Minimum Wages Act (whichever is higher). Rates must be inclusive of fuel and all Human Resource-related statutory compliances including PF, Labor Cess, and ESI (as detailed in Annexure II of the RFP). Each vehicle/crane requires **4 Drivers/Operators** (including relievers) per location.

Annexure C4

Detailed location maps, site layouts, and access points

National Highways Infra Trust

 National Highways Infra Trust	Detailed location	Doc No.: NHIT/FY25-26/RFP/ Incident Management
--	--------------------------	--

1. Palanpur – Abu Road (NH-27)

A four-lane road on NH-27 with project length of 45 kms.

It starts from north of Palanpur in Gujarat at km 601+000 and ends at km 646+000, south of Abu Road in the state of Rajasthan. The asset has one toll plaza at Khemana (km 602+750). This road is one of the key connectors between western Gujarat and Rajasthan and other northern and eastern Indian states. NH-27, the second-longest highway in India, starting from Porbandar in Gujarat and ending at Silchar in Assam, while passing through the states of Rajasthan, Madhya Pradesh, Uttar Pradesh, Bihar and West Bengal. The Palanpur-Abu Road caters to the north-west movement between Haryana, Punjab, Delhi, in the north and the different business centres of Gujarat. It also caters to east-west movement between Silchar, Guwahati, Siliguri, Lucknow and Udaipur in eastern India and industrial cities like Morbi, Jamnagar and Gandhidham, and ports such as Kandla and Mundra in Gujarat. Consequently, the commercial traffic on the road is of long-distance in nature. The local and short distance traffic is predominantly cars, jeeps and vans (CJV) traversing between Palanpur, Abu Road, Swaroopganj, Deesa and other small towns.

2. Abu Road – Swaroopganj (NH-27)

A four-lane road on NH-27 with project length of 31 kms.

This road is adjacent to the Palanpur – Abu Road (Asset 1) and starts near Abu Road in Rajasthan at km 646+000 and ends at km 677+000 near Swaroopganj in the state of Rajasthan. The asset has one toll plaza at Undavariya (km 670+750).

Abu Road – Swaroopganj has similar traffic pattern and connectivity as Palanpur – Abu Road (Asset – 1).

3. Agra Bypass (NH-44)

A four-lane road originating on NH-19 (old NH-2) and terminating on NH-44 (old NH-3). The project length under the asses is 32.80 km.

The asset starts from junction of NH-2 (km 176+800) in the state of Uttar Pradesh at km 0+00 and ends at junction with NH-3 (km 13+ 030) in the state of Uttar Pradesh at km 32 +800. The asset has one toll plaza at Raibha (km 10+800) and acts as a bypass to the city of Agra in the state of Uttar Pradesh and a key link between Delhi and the regions of Gwalior, Maharashtra and all southern states. It further connects the traffic originating from west from areas such as Gujarat and Jaipur to the cities in the East (Kanpur, Lucknow and beyond), thereby supporting the east-west movement. This road also acts as a connector between major highways in the state of Uttar Pradesh, branches out to NH-52 (old NH-3) and NH-44 (old NH-7) at Gwalior.

National Highways Infra Trust

 <p>NHIT National Highways Infra Trust</p>	Detailed location	Doc No.: NHIT/FY25-26/RFP/ Incident Management
---	--------------------------	--

4. **Borkhedi – Wadner – Deodhari – Kelapur**

A four-lane road on NH-44 with project length of 138.15 kms.

The asset starts from south of Nagpur at Borkhedi (km 36+600), traversing through the districts of Nagpur, Wardha and Yavatmal in the state of Maharashtra and ends near Maharashtra/Telangana Border (km 175+000). The asset has two toll plazas at Darodha (km 92.500) and Kelapur (km 150.450). The toll plaza at Kelpaur is proposed to be shifted to km 156.650.

The asset is in vicinity of Nagpur, which is home to several manufacturing hubs, food processing units and CONCOR's multi modal logistics logistic hub. Yavatmal (textile/cotton), Butibori (MIDC), and Chandrapur (coal) are some of key traffic generators for the Asset.

5. **Chittorgarh – Kota (NH-27)**

A four-lane road on NH-27 with project length of 160.50 kms.

It starts near Chittorgarh in the state of Rajasthan at km 891+929 and ends near Kota in the state of Rajasthan at km 1052+429. The asset has three toll plazas at Bassi (km 929+629), Aroli (km 986+469), and Dhaneshwar (km 1032+979).

The road is part of the East – West corridor envisaged under National Highway Development Program (Phase – II). The road serves the east-west long-distance traffic which is majorly plying between Lucknow, Gorakhpur in eastern region and Palanpur, Rajkot in western region. Apart from long distance traffic, it also serves the short distance traffic which is mainly generated between Bundi, Kota, Baran, Udaipur and Chittorgarh areas.

6. **Shivpuri – Jhansi (NH-27)**

A four-lane road on NH-27 with project length of 75.30 kms.

It starts at Shivpuri in the state of Madhya Pradesh at km 1305+087 and ends at Jhansi in the state of Uttar Pradesh at km 1380+387. The road connects the districts of Jhansi in the state of Uttar Pradesh and Shivpuri in the state of Madhya Pradesh. The asset has one toll plaza at Raksha near Jhansi (km 1374+570).

In continuation to Asset 1, Asset 2 and Asset 3, this asset also forms part of NH-27. The road stretch witnesses higher proportion of long route traffic between the eastern and western regions. Asset stretch is used by the traffic originating and destined in the regions such as Kanpur – Lucknow cluster, Indore cluster, Maharashtra and Gujarat.

Annexure C5
Design requirements including
parameters for structural and safety
submissions.

National Highways Infra Trust



Design Requirements

Doc No.: NHIT/FY25-26/RFP/
Incident Management

Not Applicable

Annexure C6
Construction requirements covering
quality, workmanship, and Testing
Standards.

National Highways Infra Trust



Construction Requirements

Doc No.: NHIT/FY25-26/RFP/
Incident Management

As per Contract Data Sheet

Annexure C7

Technical Specifications based on MoRTH, IRC, and IS codes

National Highways Infra Trust

	Technical Specifications	Doc No.: NHIT/FY25-26/RFP/ Incident Management
---	---------------------------------	--

As per Contract Data Sheet

Annexure C8

Approved Drawings including layouts, GADs, and structural details

National Highways Infra Trust



Approved Drawings

Doc No.: NHIT/FY25-26/RFP/
Incident Management

Not Applicable

Annexure C9

Draft Contract Agreement

National Highways Infra Trust

 <p>NHIT National Highways Infra Trust</p>	Draft Contract Agreement	Doc No.: NHIT/FY25-26/RFP/ Incident Management
--	---------------------------------	--

Not Applicable

Annexure C10

Process of Online Bid Submission

Process/Step note for Open RFP Online Submission in NHIT

NHIT

TYASuite

Step 1

Click on the URL: - <https://nhit.tyasuite.com/#/login>

User will land on to page of Login (Refer the screenshot).

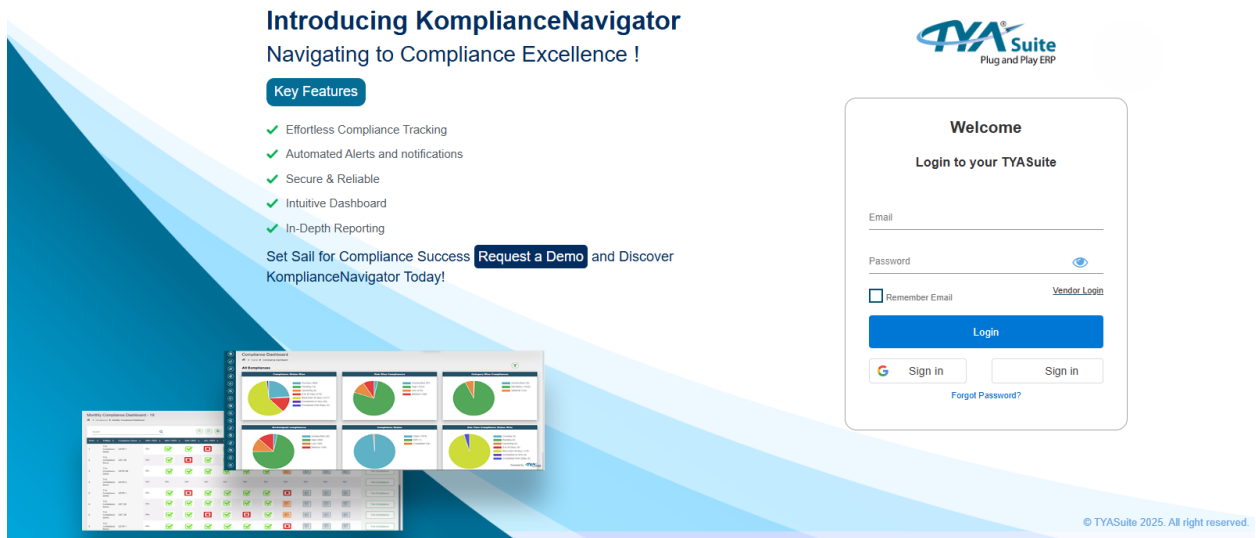

- User will fill the email ID and Password to login by clicking on Login Button.
- After login, User will land on to Dashboard of TYASuite which will look below.

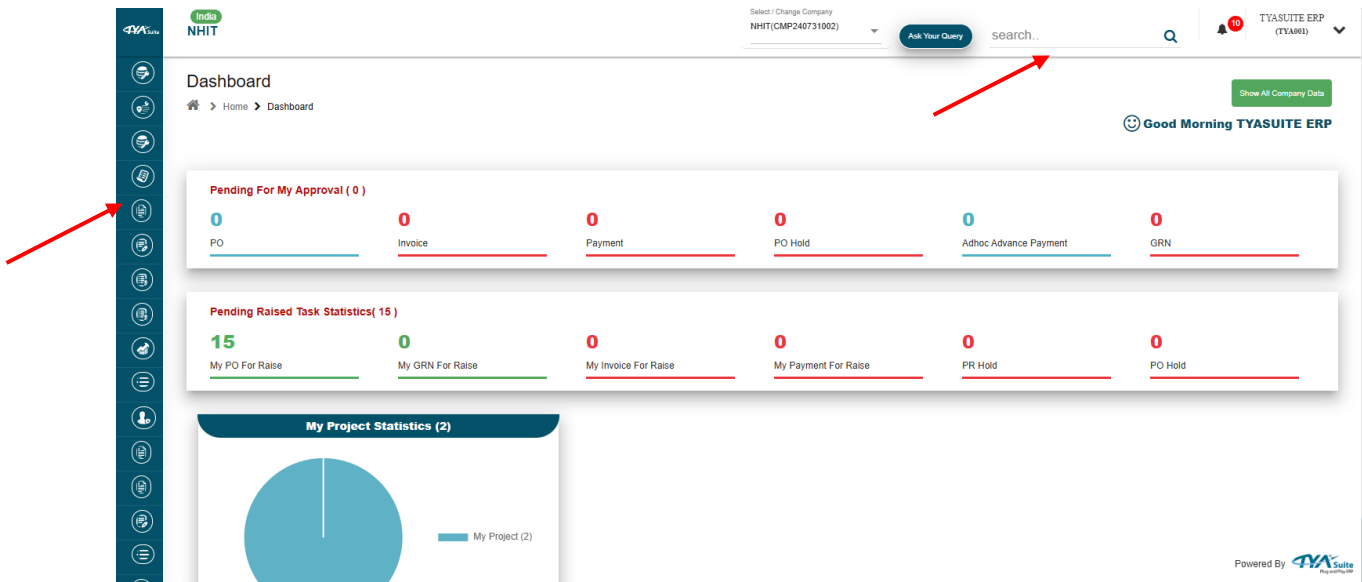

- Dashboard will reveal what access(role) the user has been given
- There is search Option in Top Right Corner as well as Menu Option in extreme left.

Step 2

- User can Search the "Open RFP" in the Search option or else it can be search through the menu option(Refer the screenshot).

The screenshot shows the TYASuite ERP dashboard. At the top right, there is a search bar with the text "open rf" and a magnifying glass icon. A red arrow points to the search bar. Below the search bar, there is a navigation menu on the left side with various options. A red arrow points to the "Open RFP" option in the menu. The dashboard also displays several statistics cards, including "Approval (0)", "Work Statistics (15)", and "My Project Statistics (2)".

- When searched, user will land on to the Open RFP Page(Refer the screenshot)

The screenshot shows the "Add Open RFP" page in the TYASuite ERP system. The page has a header with the company name "NHIT" and a search bar. Below the header, there is a form with various fields for adding a new RFP. The fields include:

- RFP Number: RFO\FY25-28\001
- RFP Name *
- RFP Description
- Date of Publication *
- Bid Due Date *
- Date of Opening F...
- Bid Close Date *
- Vendor: Select
- Selected Vendor
- Select Loc *
- Select Department
- Bill To Location *
- Employee Who can Open Financial Bid *

There are also checkboxes for "Open RFP" and "2 Step RFP". Below the form, there is a table titled "Submission of Technical Details" with the following columns: SNo., Requirements, Field Type, Is Mandatory, Attachment, and Action. The table contains one row with SNo. 1, Requirements "Label 1", Field Type "Text Box", Is Mandatory checkbox, Attachment checkbox, and Action icons.

Following are the fields mentioned in Open RFP Page.

Step 3

User will fill the following fields.

- RFP Name: - Name of the RFP has to be filled.
- RFP Description: - Description of the RFP has to be filled
- Date of Publication
- Bid Due Date
- Date of Opening Financial Bid
- Bid Close Date
- Open RFP Dropdown
- 2 step RFP Dropdown
- Employee Who can Open Financial Bid
- Employee Who can Open Technical Bid
- Technical Bid Open Date
- Submission of Technical Details
- Financial Bid Details
- Is Product Master
- Is PR
- Item Description
- UOM
- Quantity
- Remarks

After saving this, User has to submit the document for Approval (if required).

Step 4

Below is the Screenshot of “RFP Approval” Page

- User has to search the Page “Open RFP Approval” in the search box and also from “Side menus given.

List Of RFP Approval - 3

Home > Quotation Management > List Of RFP Approval

Search

S. No	RFP Number	RFP Name	Date of Publication	Bid Due Date	Date of Opening/Financial Bid	Bid Close Date	Ship To Location	Bill To Location	View
1	RFQ00023	Temp001	06.02.2025	07.02.2025	07.02.2025	08.02.2025	Kora1(000001000)	Kora1(000001000)	
2	RFQ00010	RFQTESTH	23-07-2024	24-07-2024	24-07-2024	24-07-2024	Kora1-ARC(000001001)	Kora1-ARC(000001001)	

- User has to click on eye button to see the full details of the document.
- The inside page will appear like below as per given by the Document Raiser.

RFP Number: RFQ00023
Bid Close Date: 08-02-2025

RFP Name: Temp001
Open RFP: No

RFP Description: Temp001
1 Step RFP: No

Date of Publication: 06-02-2025
Technical Bid Open Date:

Bid Due Date: 07-02-2025

Ship To Location: Kora1(000001000)

Bill To Location: Kora1(000001000)

Vendor:
• Sheet Metal Works (VEN001)
• Syed Brothers Enterprises (VEN002)

Employee Who can Open Financial Bid:
• Mohammad Harris (EMP001)

Submission of Technical Details

S.No.	Requirements	Field Type	Is Mandatory	Attachment
1	Label 1	Text Box	No	No

RFP Details:
RFP Documents

Reason for Amend:
Financial Bid Details:-
Product Master PR

S. No.	PR No	Item Description	LOM	Quantity	Remarks	Action
1		Abc0001 (Temp001)	Number	10	ok1	
2		Abc0002 (Temp002)	Number	10	ok2	
3		Abc0003 (Temp003)	Number	10	ok3	
4		Abc0004 (Temp004)	grams	10	ok4	
5		Abc0005 (Temp005)	Number	10	ok5	
6		Abc0006 (Temp006)	Number	10	ok6	

Email to send Quotation PDF:

Back Approve Reject Next

User can Approve or Reject the document by the “Approve” “Reject” Option given in the bottom of the page.

Step 5: - Vendor Login

A link will be generated that will be posted at NHIT Website

Please make sure to make a new Chrome Profile before Opening a new Link for different Entities as it is necessary to avoid login and password and Link confusions

Here is the step to make a new Google Chrome Profile

- Go to Google Chrome, Click on the Profile Name shown here.
- Click on the “Add Chrome Profile”

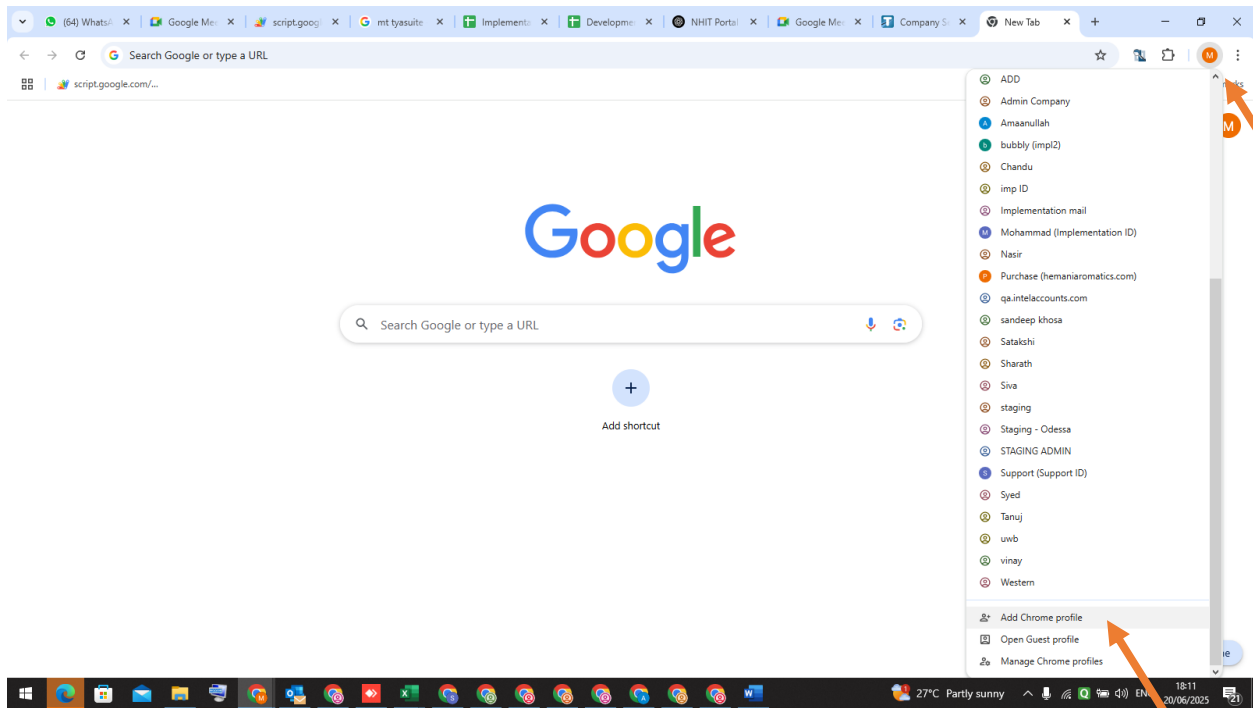

When clicked on “Add Chrome Profile” then this page will appear

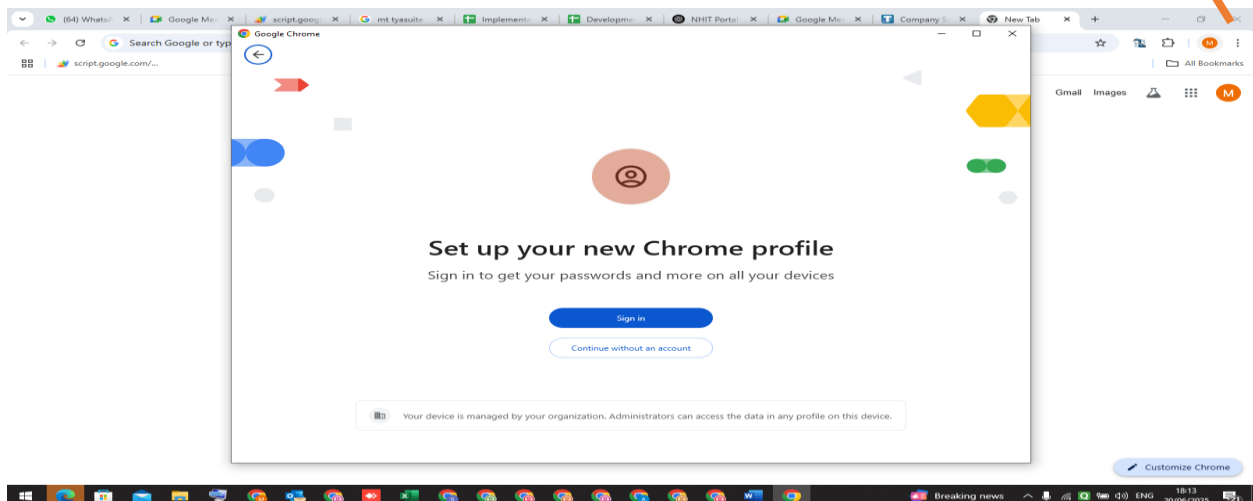

- Now click on “Continue without an Account” and the below page will appear.

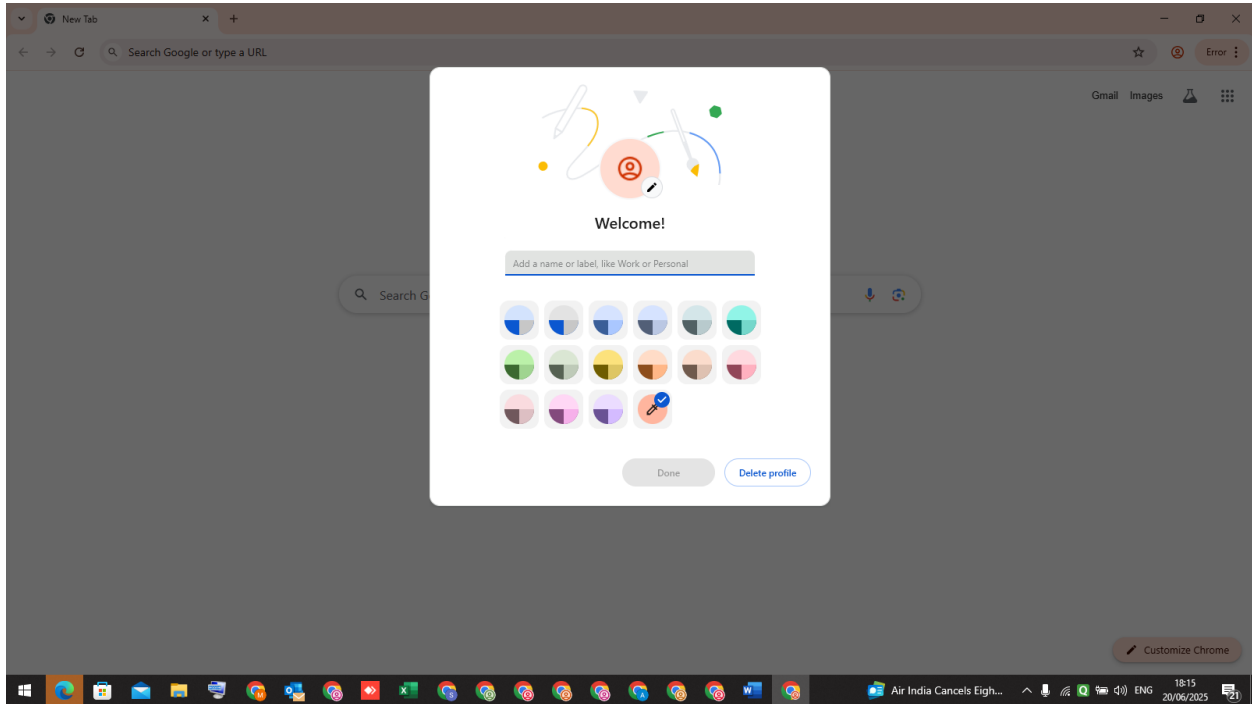

- Save the Page as per NHIT Entities Name.
- Make 5 Profiles like this as per NHIT Entities Name.
- Click on Done button to save the profile.
- Go to the NHIT Website and then Click on the Particular Link as per entity

Below are the Link for Entities

1. Link for NHIT Entity

https://mt.tyasuite.com/#/login?public_reg=04f58dac471d1d0faaf64535d127893b85780b0f7645b3164d75fca164a14af824ed37fdd34ebfa471de822f7ed82b5731194d2b15acb00867ab4d8d0a2e58e7XIX8XMQRp6YEO4tomjhtOvKBTk8EFahHxNU8jOFKdn0C1KUn8SEap3bjeivM2Ft8t+zKHgS wbn5QC2gMpVTopDQB2r1joYyc1aSsVMsIaRRyfWbM3cVrQ+XQZv6N5Ny1A2f1Oq382feeBXbfuFDPYNC5dQvXyqtN/g1BxtMSRel/KIlp4kJK8Yonvd62U5JU

2. Link for NHIM

https://mt.tyasuite.com/#/login?public_reg=72551be97dae469d4fe4569cc4346d2229cb418f68bf757bb2636c4d3a5e95f121496c8f7fac904ef8bcd3c4b7c616ba2bd844a0bc42e1d9526bfd085e42be910ZteJX4Co9XZe/rlwvKafqi3UTpF+CmeEHrfM+p07LCXvwpNF4eiRvTxEBQyqlmzC6o3HjmO7RYCstrcaqMwM0989orvkZuE7zOjDgnvjLXHTzNRwYUGGUdSXF74bag0TTEHGsbWl9Je1wD4INFTKxdh8gAaUGqRY8lSqnc8DzRvZ/m8nl0Afha1MQerHmg

3. Link for NEPPL

https://mt.tyasuite.com/#/login?public_reg=0aaf37e9251457250bff3a42962adec3e4c963c4fe62f3674b56a05bb61abd8c49036f1cb243563de6e29889c0d918c288b026c0e10cea049e1e4dc9749c6feUOISboLsfsgxttbBmGfGMhZvfgE3cq/o12st2oxgnx9O8hIWpxoNkcD6OARqDpwnLGgoGC34NZq47bHc3Mj79iZNpeShehqListmrISSBvmFz8RMdiumQwmwwKSdr7utlTpQ1NKZc1wvfJFsSwo4QbTWW2hoNoDHIWsDKcMeZ3M5jR2V2qdYcl+9hUUcEC

4. Link for NWPPL

https://mt.tyasuite.com/#/login?public_reg=7e8739a27948fbce39f896f0b2e8b98f6f5ed8c28d55ac4d64d235cc85bfa3f4ef0a1e5ce7d38e9edf054de6053fee0acac8d11c03992fa656fe30115276700eOdpNDZMB6a7OdbYck5yXlzWAMBopvINRNATyn29jj6gUFYruvZvysjU3QNSELc3Yy9h7WtGEBrIK4g0W1Dgn/i6/GrhwX+rxMIXrfMFOjg6MLYyfGkiDHBLyg06JFKQLUgZLNgY+BwFXMs8U+TatiJPkncDdovJ9NDb1Jis09d0EDwz1jfdG8etvV9nY7F

5. Link for NSPPL

https://mt.tyasuite.com/#/login?public_reg=a68f9eb277f60f168baa8741dfe10abafce830477598258b192b19bfaf9cca6a76998090da77762f1bd37d839666d73407652b051215da7d2169b62ffc68261KCwrUfyZ75pjfglV/nwSsN9I1z5ZARaxNx6+1xiUpJsfMhDDqgJpDPVX/K0nzCDAm7Vjs90ldJs sepMZ7ToBx5B+7lxGClxe37NLRyokTPx11uNnDmEQFFGeZ+kr7W77bLcWiXlSr5io1V1q/9o8NzmAz785JjVrrzUj7MHE4C5KhgUvi3tDGJxdEnSysrb

- Vendor will click on the Link and land on to Vendor Login Page (Refer the screenshot below).

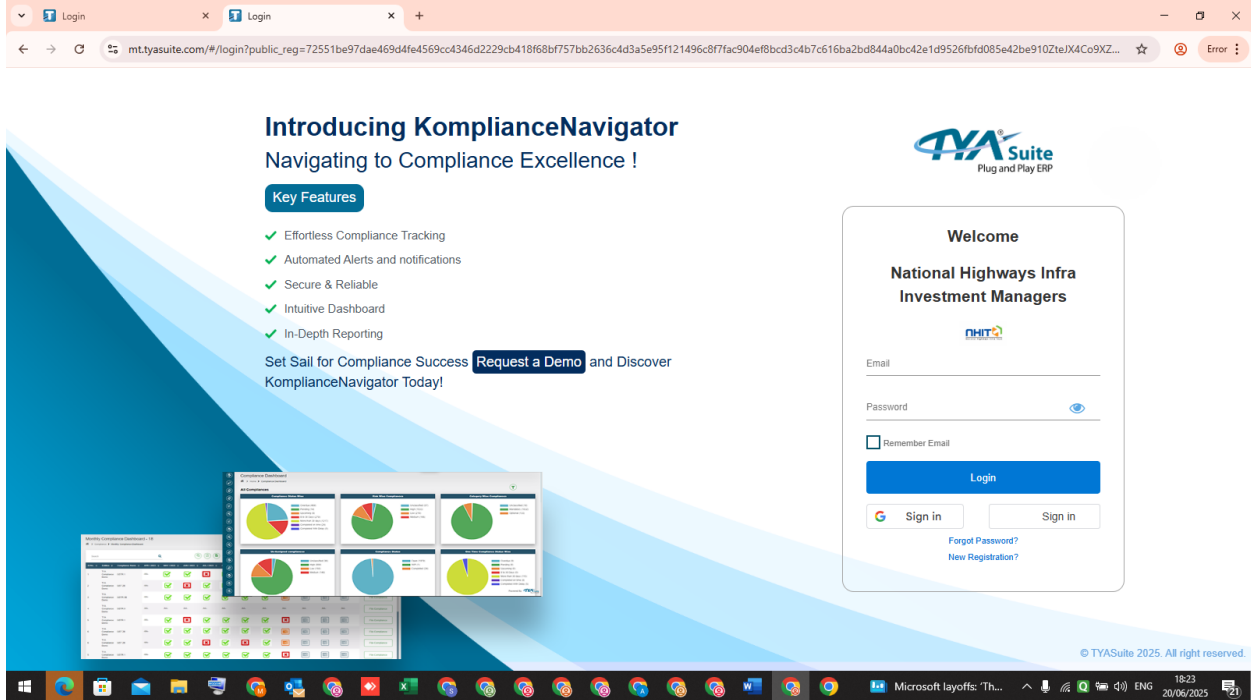

- Here If the Vendor is already registered to NHIT – TYASuite Portal so the Vendor can Directly put the Login ID and Password.
- If the Vendor is new and He has to registered with the Option of **“New Registration”**.
- When Vendor Clicks on **“New Registration”** then a Page appears to submit some basic details in order to submit the registration details.

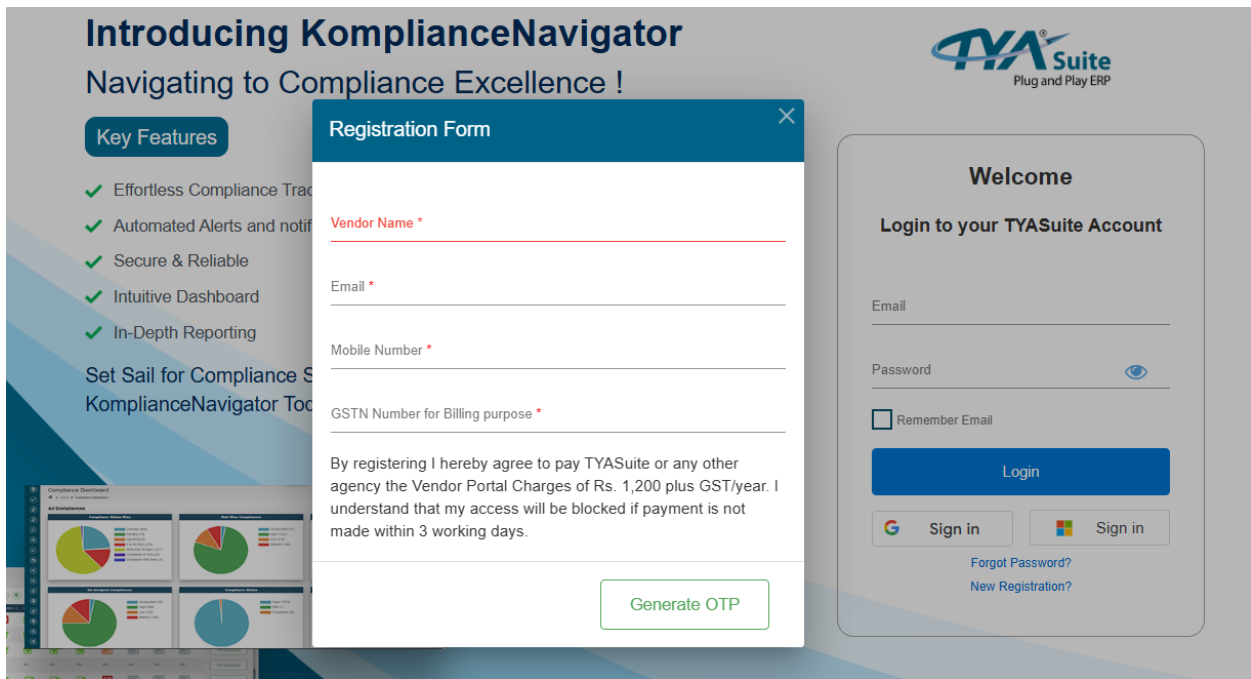

- Vendor will submit the following details

- a. Vendor Name
 - b. Email
 - c. Mobile Number
 - d. GSTN Number for Billing Purpose.
- Vendor will submit the details and OTP will be sent to the mail ID given and after He will create a password for Login.
 - When the Password is generated then He can login to the Portal (Vendor Portal), The portal will look like below.

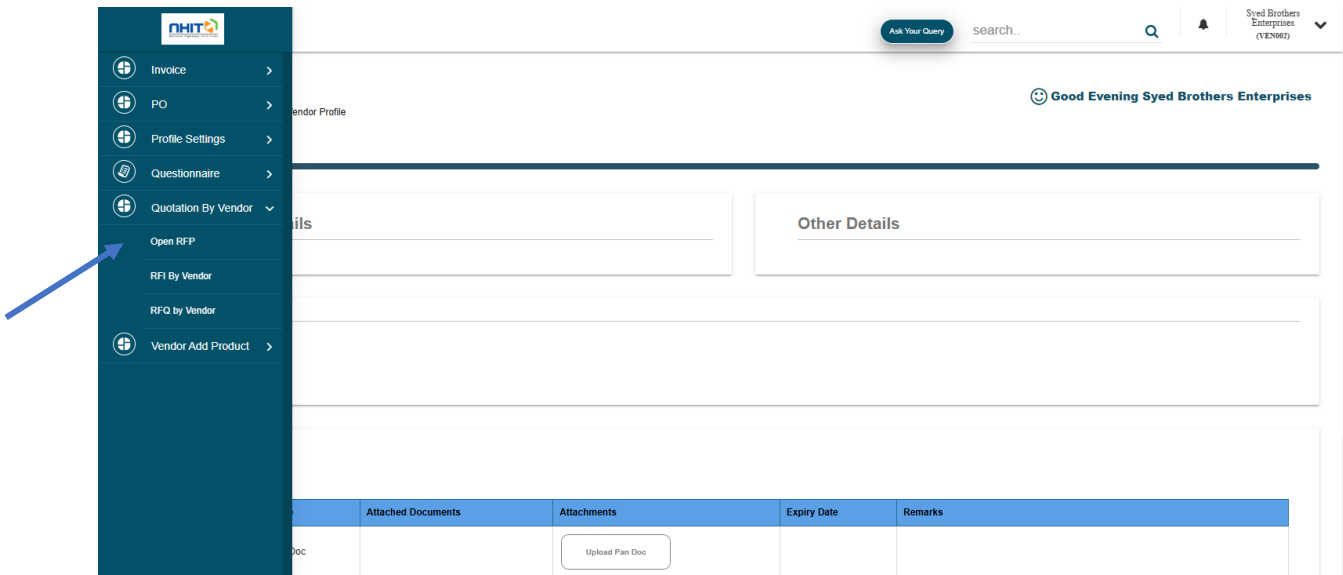
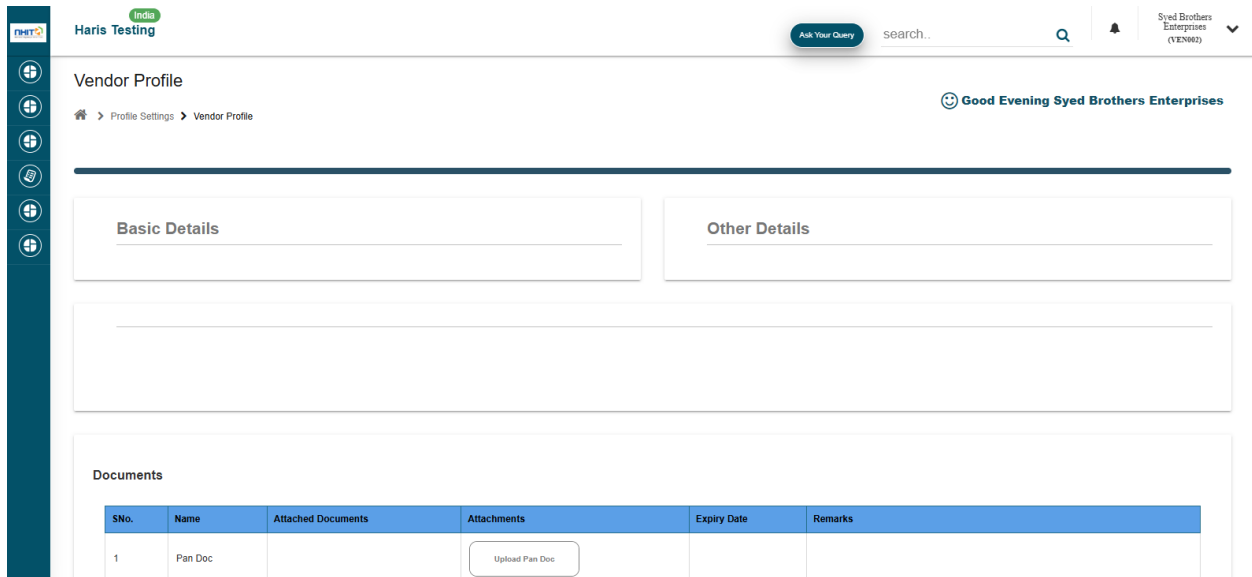

- When Vendor will click on “Open RFP” from Menu Bar then following page will open.
- List of Open RFPs will appear in the Page. Vendor shall

List Of Open RFP - 5

Home > Quotation By Vendor > List Of Open RFP

SL.NO.	RFQ Number	RFQ Name	RFQ Start Date	RFQ End Date	Technical Bid Open Date	Bid Open Date	Bid Close Date	Status	Date Added	Last Action
1	RFQ00052	RFQ OPEN Test8	2025-04-16 17:25:14	2025-04-16 18:25:21	2025-04-16 18:28:03	2025-04-16 18:41:21	2025-04-16 18:54:21	Active	2025-04-16 15:58:27	20:15:
2	RFQ00051	OPEN RFP Test3	2025-04-10 16:08:19	2025-04-10 16:26:24	2025-04-10 16:28:24	2025-04-10 16:39:24	2025-04-10 16:51:24	Active	2025-04-10 14:39:49	20:15: Response Submit Time Over
3	RFQ00050	OPEN RFP Test1	2025-04-09 16:28:50	2025-04-09 16:46:59	2025-04-09 16:47:25	2025-04-09 16:54:59	2025-04-09 17:05:59	Active	2025-04-09 15:06:59	20:15: Response Submit Time Over

- Vendor will submit the Response after clicking on “+” button.
- Vendor will see the following details once he clicks on + button.

RFQ Number : RFQ00052	RFQ Name : RFQ OPEN Test8	RFQ Description : RFQ OPEN Test8	RFQ Start Date : 2025-04-16 17:25:14	RFQ End Date : 2025-04-16 18:25:21	Bid Open Date : 2025-04-16 18:41:21
Bid Close Date : 2025-04-16 18:54:21	Responsible Person Name :	Responsible Person Email :	Send RFQ to Vendor : No	Remarks :	
RFQ Location : Pune1 (000001000)	Bid Location : Pune1 (000001000)	RFI Number :	Notes : Address Employee Who Can Open Bid: Muralidharan Murthy (00000001)		
Open RFP : Yes	2 Step RFP : Yes		Technical Bid Open Date : 2025-04-16 18:28:03		

RFQ Details

Hi Vendor

RFQ Filing Activity List

Sl No.	Requirements	Value	Attachment	Remarks
1	Label 1:	Submitted		Ok

Uploaded RFQ Documents

S. No.	Item Description	UOM	Quantity	GST Type	Item Unit Price (INR ₹)	Total Unit Price (INR ₹)	Total Amount (INR ₹)	Vendor Remarks	Company Attachments	Vendor Attachments
1	NUT & LIND SCREWS (PHD001)	Pair	10	Standard	100	100	1000	ok		
Total							1000			

- Vendor has to submit the Technical Details with Attachment in the Activity Table and Financial details in Product Table with Pricing and attachments.
- Once Vendor Submits the details, he can change the details till the Bid Time is over.

Step 6: Open RFP Technical Response (Employee Login)

Employee can login to the Portal and can check the Response submitted by the once Bid Due Time is Over.

- User can click on Eye button appearing against the RFP created listing below in the screenshot.

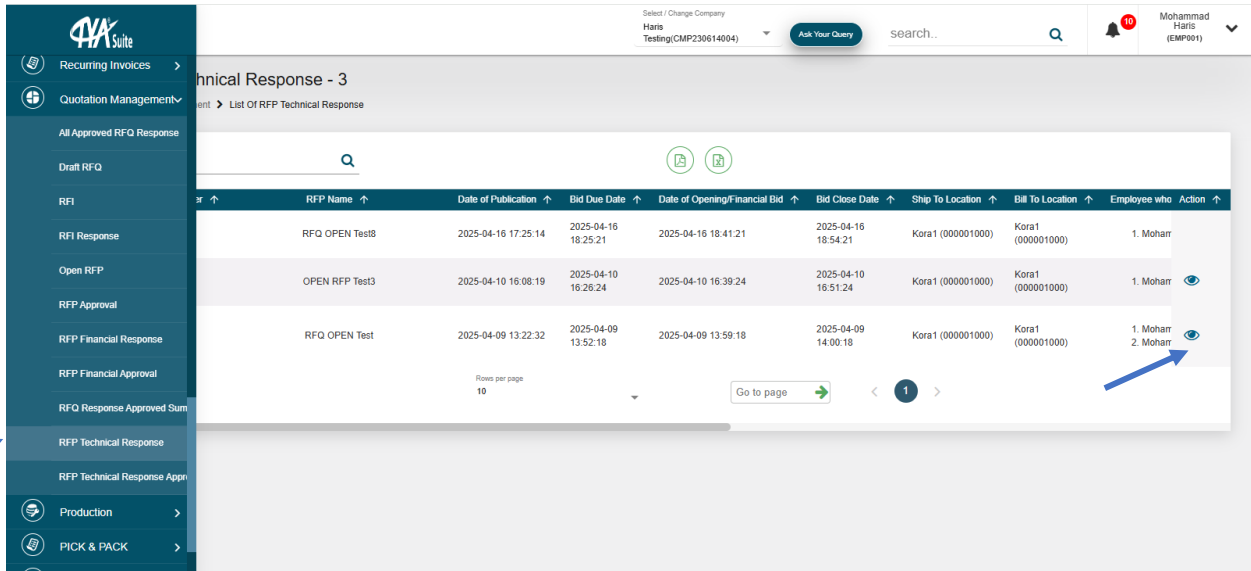

- User can see a Column in Dashboard as “Numbers of Vendors Responded” where counts of the Vendors will appear which will be clickable

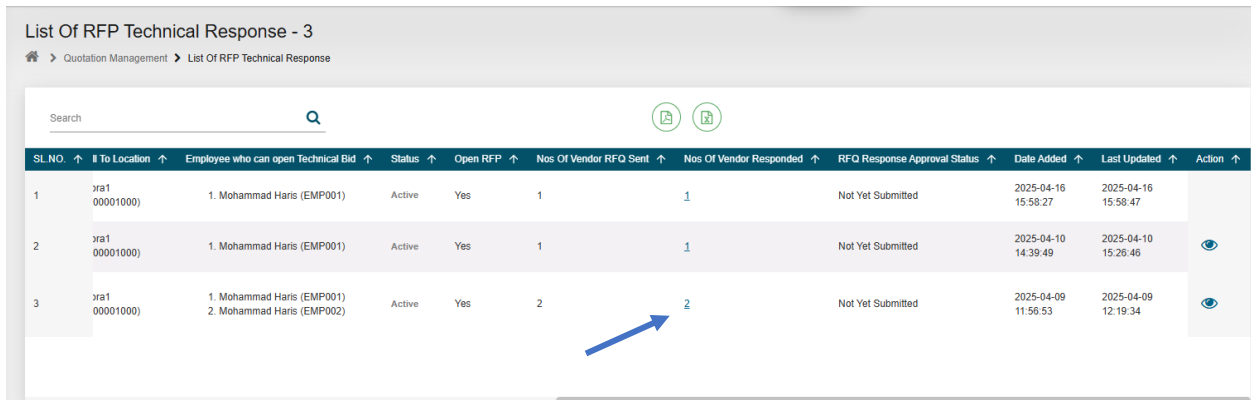

- Details of Vendors will appear once the count is clicked like below screenshot

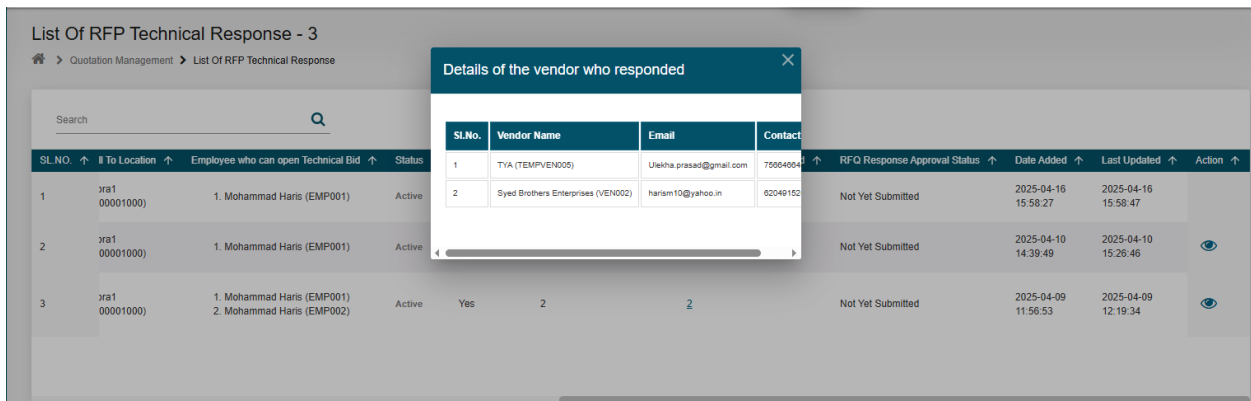

- When User will click on eye Icon and can see the Technical Details submitted by the Vendors at one go like below(refer the screenshot).

RFP Number: **RF020040** RFP Name: **RFQ OPEN Tool** RFP Description: **RFQ OPEN Tool** Date of Publication: **2023-04-09 13:22:32** Bid Close Date: **2023-04-09 13:30:19** Date of Opening Financial Bid: **2023-04-09 13:30:19**

Bid Control No: **2023-04-09 14:03:18**

Product Sub Category: **Tools**

Employee who can open Technical Bid: **Abdul (2000019452)** Bid To Location: **Kuwait (2000019452)**

Other Employees: **Mohammad Hani (2000019452)**, **Mohammad Hani (2000019452)**

RFP Details: **Submission of Technical Details**

Sl No.	Item	Requirements	File Type
1		Label 1	Text File
2		Label 2	Text File

Search:

Submission of Technical Details **Is Technically Qualified**

Sl No.	Item	Requirements	File Type	Attachment	Vendor Remarks	Remarks
1		Label 1	Text		Label 1	
2		Label 2	Text		Label 2	

Submission of Technical Details **Is Technically Qualified**

Sl No.	Item	Requirements	File Type	Attachment	Vendor Remarks	Remarks
1		Label 1	Text		Label 1	
2		Label 2	Text		Label 2	

- User has to check the details of submission for each Vendors and qualify the Vendors by clicking on **“Is Technically Qualified”**.
- Once checked and marked, the user has to submit the Technical Response for Approval.
- User has to go the **“RFP Technical Approval”** and approve it.

List Of RFP Technical Response Approval - 0

Home > Quotation Management > List Of RFP Technical Response Approval

Search:

SL NO.	RFP Number	RFP Name	Date of Publication	Bid Due Date	Date of Opening/Financial Bid	Bid Close Date	Ship To Location	Bill To Location	Employee who can open Technical Bid	St	Action
No Data Available											

Step 7: - RFP Financial Response

Once the Technical response has been submitted then RFP Financial Response will be opened by the User to see the Financial Response

List Of RFP Financial Response - 24

Quotation Management > List Of RFP Financial Response

Search Open RFP Response

SL.NO.	RFP Number	RFP Name	Date of Publication	Bid Due Date	Date of Opening/Financial Bid	Bid Close Date	Ship To Location	Bill To Loca	Action
1	RFQ00052	RFQ OPEN Test8	2025-04-16 17:25:14	2025-04-16 18:25:21	2025-04-16 18:41:21	2025-04-16 18:54:21	Kora1 (000001000)	Kora1 (000001000)	Show Rank To Vendor
2	RFQ00051	OPEN RFP Test3	2025-04-10 16:08:19	2025-04-10 16:26:24	2025-04-10 16:39:24	2025-04-10 16:51:24	Kora1 (000001000)	Kora1 (000001000)	Show Rank To Vendor
3	RFQ00049	RFQ OPEN Test	2025-04-09 13:22:32	2025-04-09 13:52:18	2025-04-09 13:59:18	2025-04-09 14:00:18	Kora1 (000001000)	Kora1 (000001000)	Show Rank To Vendor
4	RFQ00047	RFQT144345bg	2025-03-21 13:09:52	2025-03-21 17:09:57			Kora1 (000001000)	Kora1 (000001000)	Show Rank To Vendor

- User has to click on eye button to see the Financial Response.
- The Financial Response will be seen for those Vendors which has been Technically qualified.

Submission of Technical Details

Sl.No.	Requirement	Fact Type	Attachment
1	Label 1	Text Box	
2	Label 2	Text Area	

Search

Submission of Technical Details

(1) Vendor : (000001000)

Sl.No.	Requirement	Fact Type	Attachment
1	Label 1	Text Box	
2	Label 2	Text Area	

(2) Vendor : (000001000)

Sl.No.	Requirement	Fact Type	Attachment
1	Label 1	Text Box	
2	Label 2	Text Area	

RFQ Documents

Vendor Selection Type

S. No.	Vendor Description	(%) (000001000)	(%) (000001000)	Vendor Name
1	NOTE AND SCHEDULE (P0001)	100%	100%	

- User will see the Financial + Technical Response and after seeing and selection of Vendor, He can submit the Financial Response.
- User will go to the RFP Financial Approval Page and approve the Line item

List Of RFP Financial Approval - 5

Quotation Management > List Of RFP Financial Approval

Search

SL.NO.	RFP Number	RFP Name	Date of Publication	Bid Due Date	Date of Opening/Financial Bid	Bid Close Date	Ship To Location	Bill To Location	Employee WH	Action
1	RFQ00048	OPEN RFP Test	2025-04-09 11:41:11	2025-04-09 12:15:17	2025-04-09 12:31:17	2025-04-09 12:40:17	Kora1 (000001000)	Kora1 (000001000)	1. Mr	
2	RFQ00015	RFQTEST478	2024-12-20 10:04:37	2024-12-20 10:10:42	2024-12-20 10:10:42	2024-12-20 10:14:42	Kora1 (000001000)	Kora1 (000001000)		
3	RFQ00014	MAIL Test	2024-12-18 16:29:14	2024-12-18 18:29:20	2024-12-18 18:30:20	2024-12-18 18:35:20	Kora1 (000001000)	Kora1 (000001000)	1. Mr	

Step 8: - All Approved RFP Response(Raise PO)

From here A PO can be raised from “All Approved RFP Response”.

List Of All Approved RFQ Response - 18

Home > Quotation Management > List Of All Approved RFQ Response

Search

SL NO.	RFP Number	RFP Name	Date of Publication	Bid Due Date	Date of Opening/Financial Bid	Bid Close Date	Ship to Location	Bill To Location	Employee Who can Open F	Action
1	RFQ00050	OPEN RFP Test1	2025-04-09 16:28:50	2025-04-09 16:46:59	2025-04-09 16:54:59	2025-04-09 17:05:59	Kora1 (000001000)	Kora1 (000001000)	1. Mohammad Harris (E	 Raise PO Raise Customer Quotation Update Agreement
2	RFQ00046	RFQTESTusvender	2025-03-18 13:24:24	2025-03-20 13:25:29			Mum (000004000)	Mum (000004000)		 Raise PO Raise Customer Quotation Update Agreement